

SUB-STRUCTURES

INTRODUCTION

1. This section is comprised of insulator and shield plates that are the building blocks to all of the vertical primary plates and parts of others. Plates not including required combinations for overhead construction can be modified by calling for Sub-Structures instead of plates. They can also be used to see a more detailed breakdown of the components that make up a construction standard.
2. Split bolt assembly (SH30) is required on all wood poles 45 feet and larger at seven (7) inches from the tip, 90 degrees from the birthmark side of the pole. Not required for poles with SH4 shield. Split bolts are included with wood pole plates, but can be plated separately if necessary.
3. Jumper pin locations are indicated in the following sections:
TRANSFORMERS, SYSTEM PROTECTION, REGULATORS & CAPACITORS,
AND RISER POLES.
The plate P1-1 has an option "JP" when using it for this application. Call for the required number as shown on the plates.
4. Plate options are listed in the upper left-hand corner of each plate sheet. When plating, call for the plate name followed by an asterisk and then the particular option. Other than the JP options mentioned above, the option is the primary conductor size.

Example: DHLC*636

DHLC

HOT-LINE CLAMP

OPTIONS: 6CU, 4CU, 2CU, 1/0CU, 2/0CU, 4/0CU, 500CU, 6, 4, 2, 1/0, 2/0, 3/0, 336, 636

BOLT PLATE: NONE

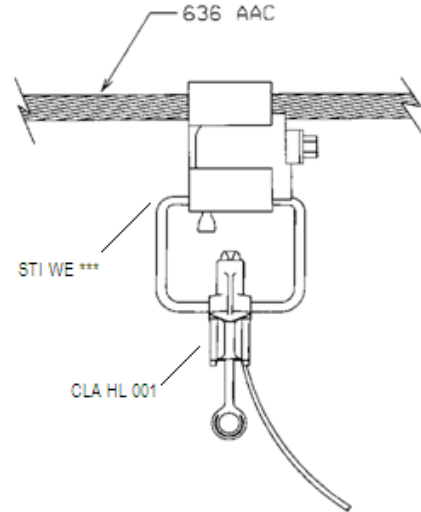
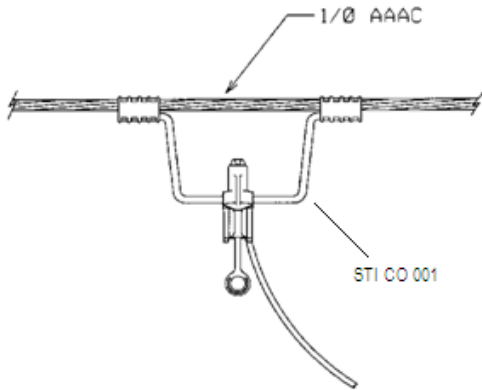

NO.	ITEM ID	QTY	DESCRIPTION
			FOR #2 AND 1/0 AAAC CONDUCTOR
1	CLA HL 001	1	GENERAL CODE FOR HOT-LINE CLAMP
2	STI CO 001	1	GENERAL CODE FOR COMPRESSION STIRRUP
	OR		FOR 336 AND 636 CONDUCTOR
1	CLA HL 001	1	GENERAL CODE FOR HOT-LINE CLAMP
2	STI WE ***	1	GENERAL CODE FOR BOLT-ON STIRRUP
	OR		FOR COPPER CONDUCTOR
1	CLA HL 001	1	GENERAL CODE FOR HOT-LINE CLAMP
2	CNN ** ***	2	GENERAL CODE FOR CONNECTOR

P1

0 TO 10 DEGREE ANGLE

OPTIONS: 2, 1/0, 3/0, 336, 636

BOLT PLATE: NONE

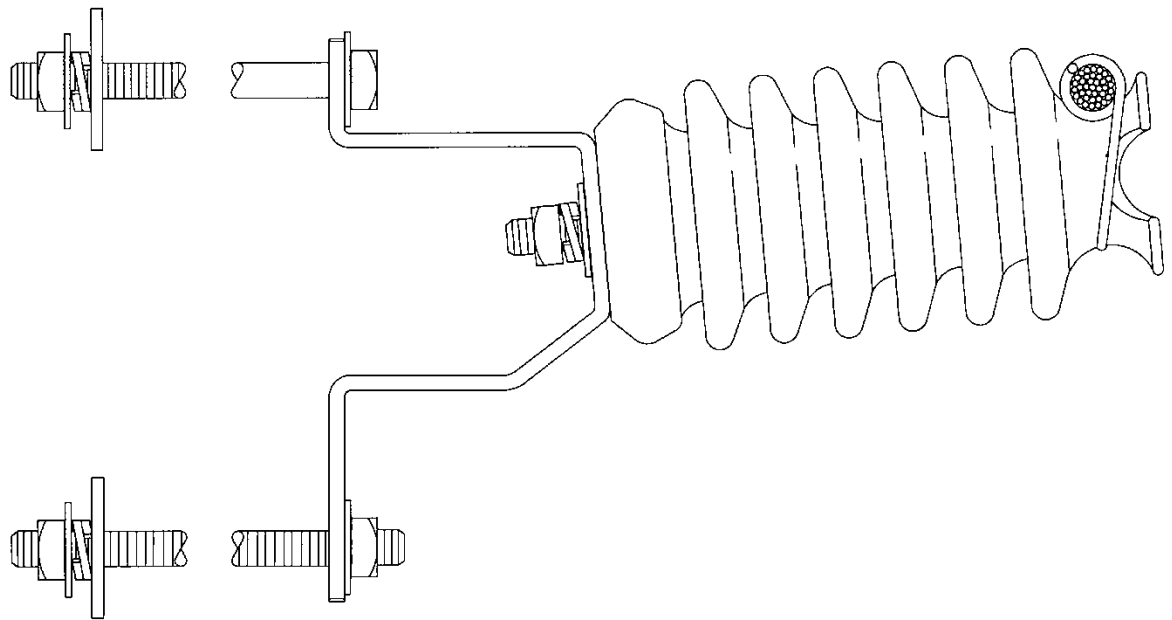

NO.	ITEM ID	QTY	DESCRIPTION
1	BOL MS 035	1	BOLT, MACHINE, SQUARE HEAD 3/4X12
2	BOL DA 015	1	BOLT, DOUBLE ARMING, 3/4X14
3	BKT IN 007	1	BRACKET, INSULATOR STANDOFF 6 IN.
4	INS VP 001	1	INSULATOR, POST 34.5KV
5	STU LI 001	1	STUD, LINE POST 3/4 HEAD - 3/4 DIA. X 1-3/4 IN. SHANK
6	TIE PR ***	1	GENERAL CODE FOR PREFORMED TIE
7	WAS RD 005	5	WASHER, ROUND, 2 INCH, FOR 3/4 IN. DIA. BOLT
8	WAS SP 002	2	WASHER, SPRING, DOUBLE HELIX, FOR 3/4 IN. DIA. BOLT
9	WAS SF 003	2	WASHER, SQUARE, FLAT, 3 IN., FOR 3/4 IN. DIA. BOLT

P1-1

0 TO 10 DEGREE ANGLE

OPTIONS: 2, 1/0, 3/0, 336, 636, JP

BOLT PLATE: NONE

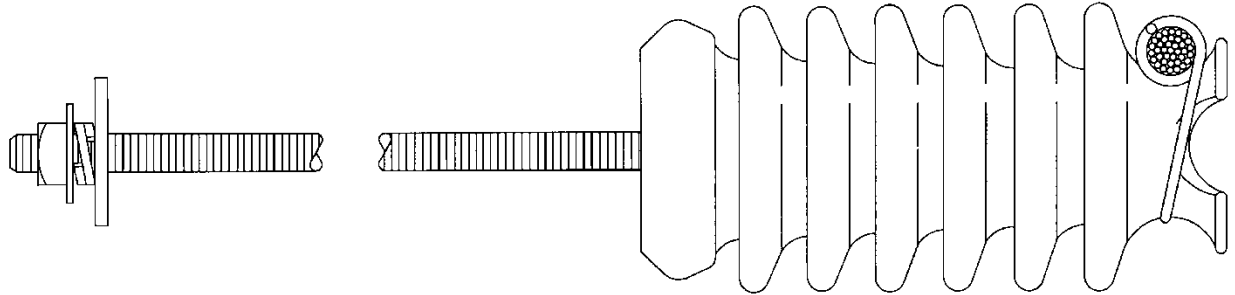

NO.	ITEM ID	QTY	DESCRIPTION
1	BOL DA 015	1	BOLT, DOUBLE ARMING, 3/4X14
2	INS VP 001	1	INSULATOR, POST 34.5KV
3	TIE PR ***	1	GENERAL CODE FOR PREFORMED TIE
4	WAS RD 005	1	WASHER, ROUND, 2 INCH, FOR 3/4 IN. DIA. BOLT
5	WAS SP 002	1	WASHER, SPRING, DOUBLE HELIX, FOR 3/4 IN. DIA. BOLT
6	WAS SF 003	1	WASHER, SQUARE, FLAT, 3 IN., FOR 3/4 IN. DIA. BOLT

P1-2

0 TO 10 DEGREE ANGLE

OPTIONS: 2, 1/0, 3/0, 336, 636

BOLT PLATE: NONE

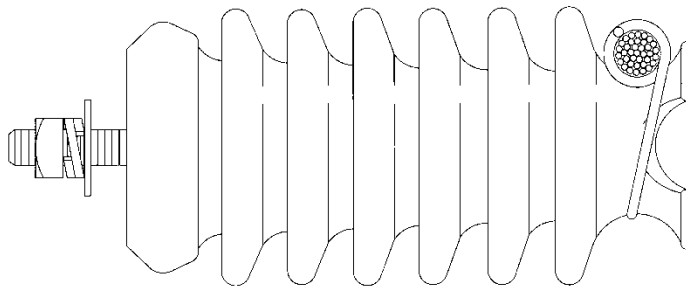

NO.	ITEM ID	QTY	DESCRIPTION
1	INS VP 001	1	INSULATOR, POST 34.5KV
2	STU LI 001	1	STUD, LINE POST 3/4 HEAD - 3/4 DIA. X 1-3/4 IN. SHANK
3	TIE PR ***	1	GENERAL CODE FOR PREFORMED TIE
4	WAS RD 005	1	WASHER, ROUND, 2 INCH, FOR 3/4 IN. DIA. BOLT

P1-3

JUMPER SUPPORT

OPTIONS: NONE

BOLT PLATE: NONE

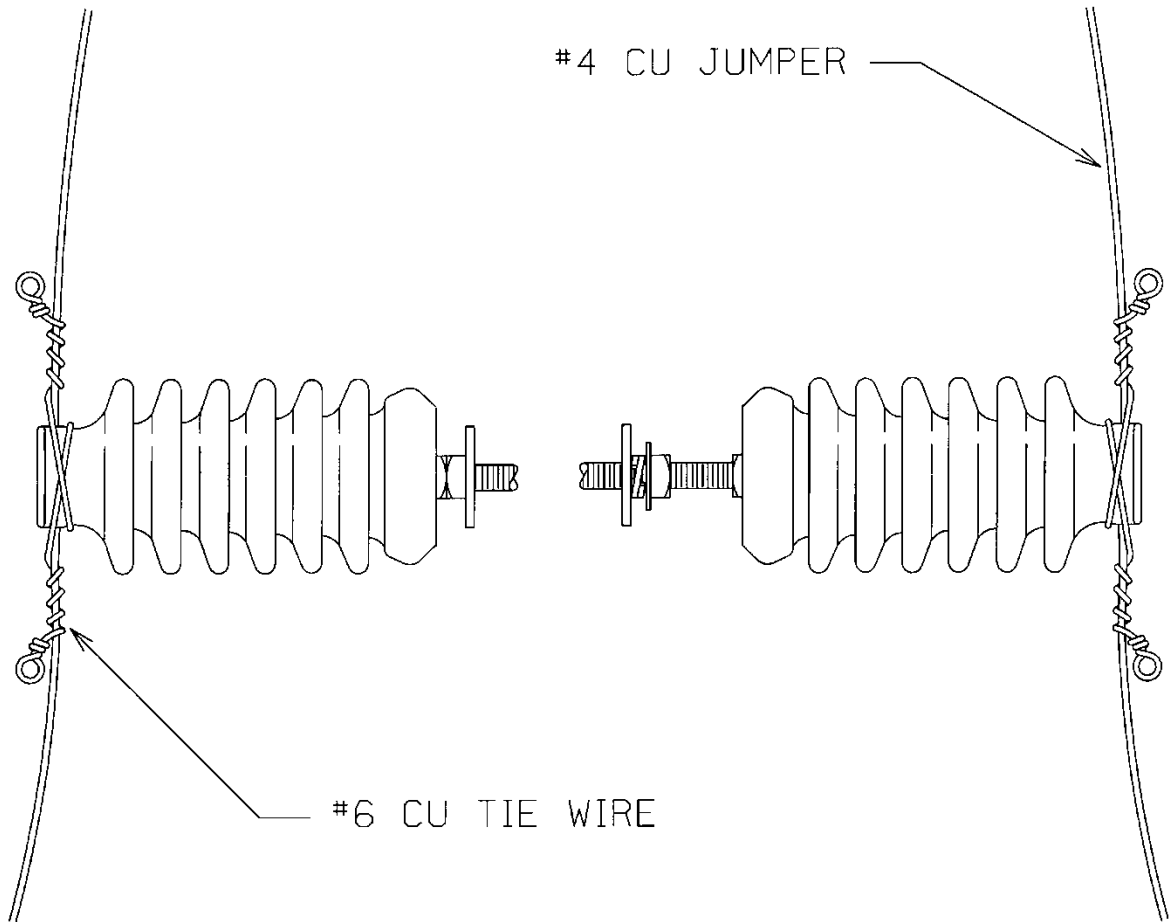

NO.	ITEM ID	QTY	DESCRIPTION
1	BOL DA 015	1	BOLT, DOUBLE ARMING, 3/4X14
2	COB CO 028	5	CONDUCTOR, BARE COPPER #4 SOFT DRAWN
3	INS VP 001	2	INSULATOR, POST 34.5KV
4	WAS RD 005	1	WASHER, ROUND, 2 IN. DIA., FOR 3/4 IN. DIA. BOLT
5	WAS SF 003	2	WASHER, SQUARE, FLAT, 3 IN., FOR 3/4 IN. DIA. BOLT
6	WAS SP 002	1	WASHER, SPRING, DOUBLE HELIX, FOR 3/4 IN. BOLT

P1-4

JUMPER PIN

OPTIONS: 2, 1/0, 3/0, 336, 636

BOLT PLATE: NONE

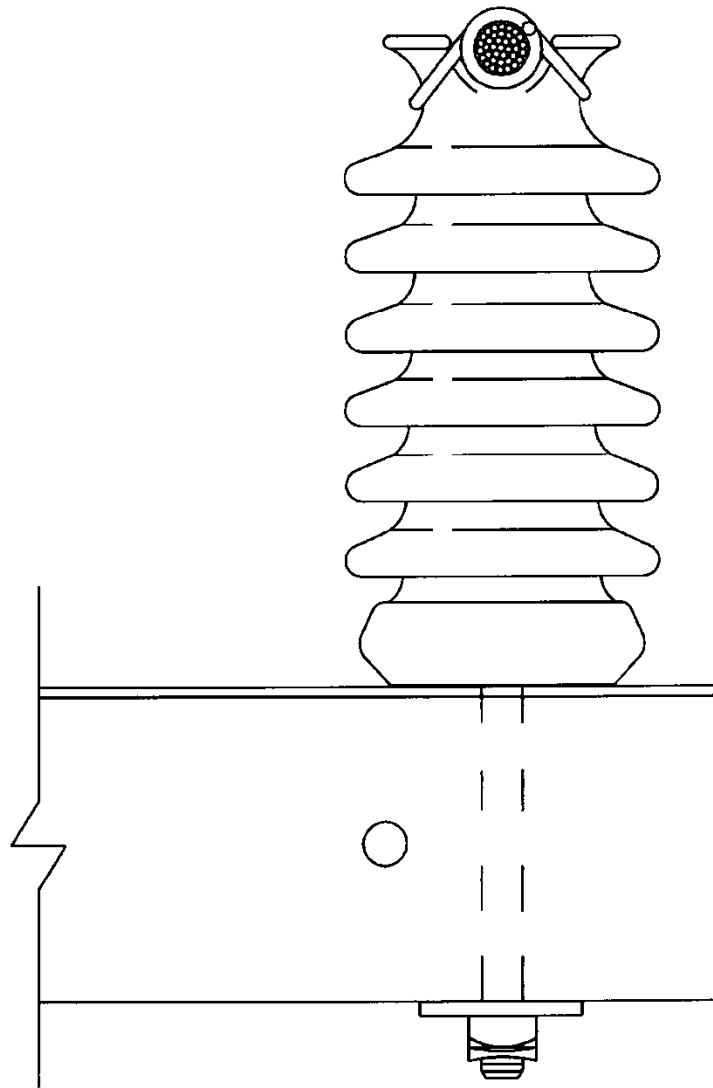

NO.	ITEM ID	QTY	DESCRIPTION
1	INS VP 001	1	INSULATOR, POST 34.5KV
2	STU LI 003	1	STUD, LINE POST 3/4 HEAD - 3/4 DIA. X 7 IN. SHANK
3	TIE PR ***	1	GENERAL CODE FOR PREFORMED TIE
4	WAS SF 003	1	WASHER, SQUARE, FLAT, 3 IN., FOR 3/4 IN. DIA. BOLT

P2

10 TO 30 DEGREE ANGLE

OPTIONS: 2, 1/0, 3/0, 336, 636

BOLT PLATE: NONE

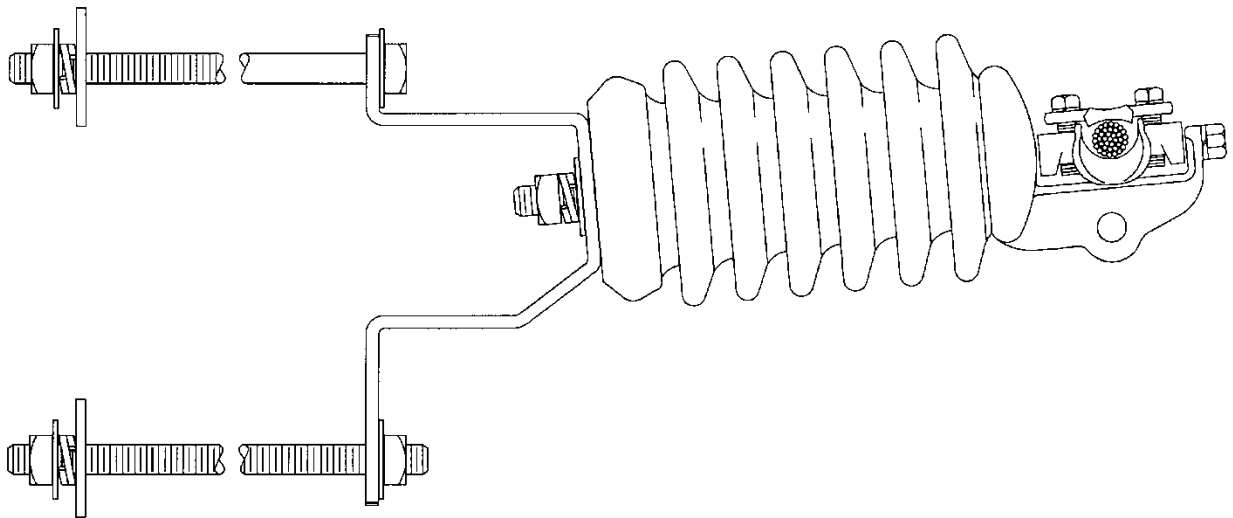

NO.	ITEM ID	QTY	DESCRIPTION
1	BOL MS 035	1	BOLT, MACHINE, SQUARE HEAD 3/4X12
2	BOL DA 015	1	BOLT, DOUBLE ARMING, 3/4X14
3	BKT IN 007	1	BRACKET, INSULATOR STANDOFF 6 IN.
4	CLA CT ***	1	GENERAL CODE FOR ANGLE CLAMP
5	GUA LI ***	1	GENERAL CODE FOR LINE GUARD
6	INS HP 001	1	INSULATOR, HORIZ. POST 34.5KV CLAMP
7	STU LI 001	1	STUD, LINE POST 3/4 HEAD - 3/4 DIA. X 1-3/4 IN. SHANK
8	WAS RD 005	5	WASHER, ROUND, 2 INCH, FOR 3/4 IN. DIA. BOLT
9	WAS SP 002	2	WASHER, SPRING, DOUBLE HELIX, FOR 3/4 IN. DIA. BOLT
10	WAS SF 003	2	WASHER, SQUARE, FLAT, 3 IN., FOR 3/4 IN. DIA. BOLT

P2-1

10 TO 30 DEGREE ANGLE

OPTIONS: 2, 1/0, 3/0, 336, 636

BOLT PLATE: NONE

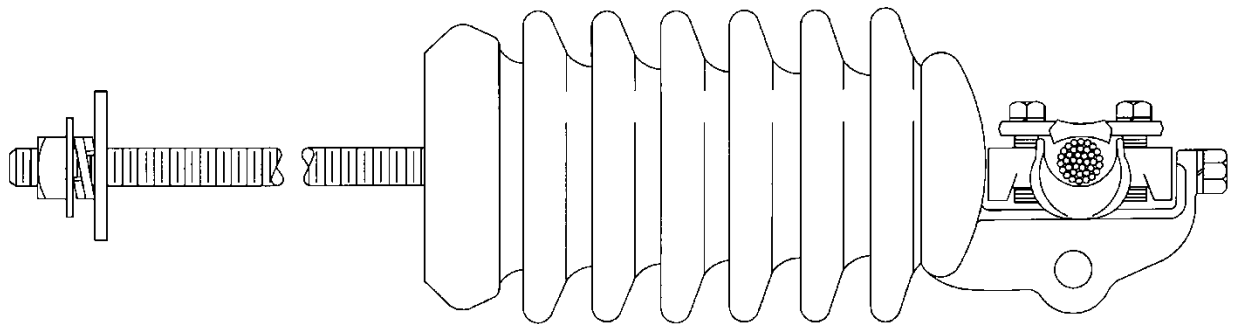

NO.	ITEM ID	QTY	DESCRIPTION
1	BOL DA 015	1	BOLT, DOUBLE ARMING, 3/4X14
2	CLA CT ***	1	GENERAL CODE FOR ANGLE CLAMP
3	GUA LI ***	1	GENERAL CODE FOR LINE GUARD
4	INS HP 001	1	INSULATOR, HORIZ. POST 34.5KV CLAMP
5	WAS RD 005	1	WASHER, ROUND, 2 INCH, FOR 3/4 IN. DIA. BOLT
6	WAS SF 003	1	WASHER, SQUARE, FLAT, 3 IN., FOR 3/4 IN. DIA. BOLT
7	WAS SP 002	1	WASHER, SPRING, DOUBLE HELIX, FOR 3/4 IN. DIA. BOLT

P2-2

10 TO 30 DEGREE ANGLE

OPTIONS: 2, 1/0, 3/0, 336, 636

BOLT PLATE: NONE

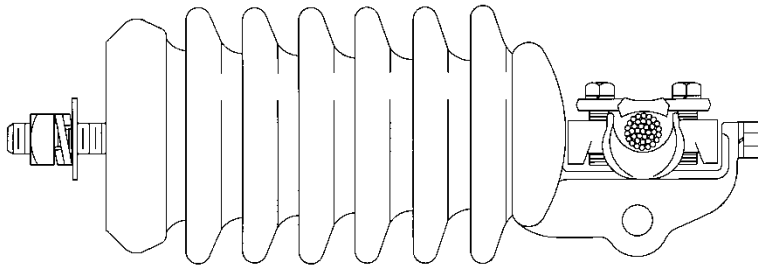

NO.	ITEM ID	QTY	DESCRIPTION
1	CLA CT ***	1	GENERAL CODE FOR ANGLE CLAMP
2	GUA LI ***	1	GENERAL CODE FOR LINE GUARD
3	INS HP 001	1	INSULATOR, HORIZ. POST 34.5KV CLAMP
4	STU LI 001	1	STUD, LINE POST, 3/4" HEAD - 3/4" DIA. X 1-3/4" SHANK
5	WAS RD 005	1	WASHER, ROUND, 2 INCH, FOR 3/4 IN. DIA. BOLT

P4

TAP OR 30 TO 60 DEGREE ANGLE

OPTIONS: 2, 1/0, 3/0, 336, 636

BOLT PLATE: NONE

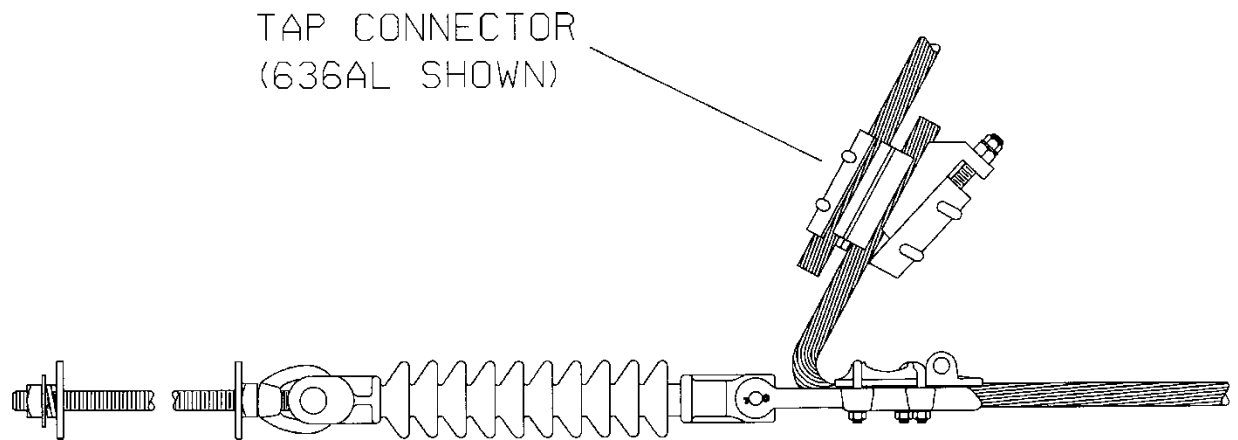

NO.	ITEM ID	QTY	DESCRIPTION
1	BOL DA 015	1	BOLT, DOUBLE ARMING, 3/4X14
2	INS CO 001	1	INSULATOR, DEADEND, POLYMER 27KV
3	CLA SS ***	1	GENERAL CODE FOR STRAIGHT STRAIN CLAMP
4	CNN ** ***	1	GENERAL CODE FOR TAP CONNECTOR
5	NUT EY 003	1	NUT, EYE 3/4
6	WAS RD 005	1	WASHER, ROUND, 2 INCH, FOR 3/4 IN. DIA. BOLT
7	WAS SP 002	1	WASHER, SPRING, DOUBLE HELIX, FOR 3/4 IN. DIA. BOLT
8	WAS SF 003	2	WASHER, SQUARE, FLAT, 3 IN., FOR 3/4 IN. DIA. BOLT

P5

DEADEND OR 30 TO 60 DEGREE ANGLE

OPTIONS: 2, 1/0, 3/0, 336, 636

BOLT PLATE: NONE

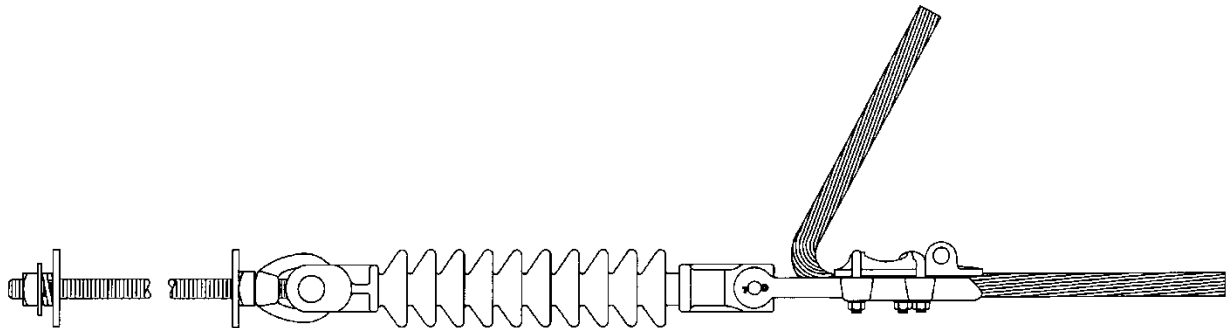

NO.	ITEM ID	QTY	DESCRIPTION
1	BOL DA 015	1	BOLT, DOUBLE ARMING, 3/4X14
2	INS CO 001	1	INSULATOR, DEADEND, POLYMER 27KV
3	CLA SS ***	1	GENERAL CODE FOR STRAIGHT STRAIN CLAMP
4	NUT EY 003	1	NUT, EYE 3/4
5	WAS RD 005	1	WASHER, ROUND, 2 INCH, FOR 3/4 IN. DIA. BOLT
6	WAS SP 002	1	WASHER, SPRING, DOUBLE HELIX, FOR 3/4 IN. DIA. BOLT
7	WAS SF 003	2	WASHER, SQUARE, FLAT, 3 IN., FOR 3/4 IN. DIA. BOLT

P7

SLACKSPAN DEADEND

OPTIONS: 2, 1/0, 3/0, 336, 636

BOLT PLATE: NONE

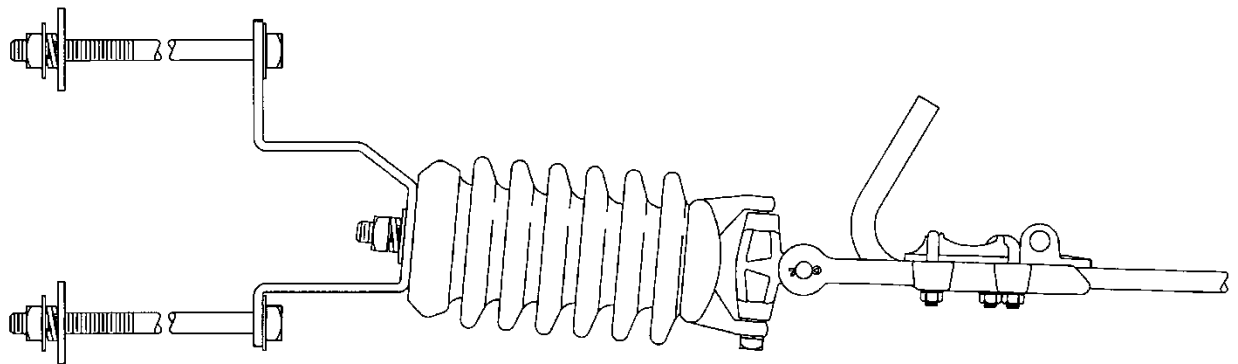

NO.	ITEM ID	QTY	DESCRIPTION
1	ADP TU 001	1	ADAPTER, TRUNION - SLACK SPANNING
2	BOL MS 035	2	BOLT, MACHINE, SQUARE HEAD 3/4X12
3	BKT IN 007	1	BRACKET, INSULATOR STANDOFF 6 IN.
4	CLA SS ***	1	GENERAL CODE FOR STRAIGHT STRAIN CLAMP
5	INS VP 002	1	INSULATOR, POST 34.5KV CLAMP
6	STU LI 001	1	STUD, LINE POST 3/4 HEAD - 3/4 DIA. X 1-3/4 IN. SHANK
7	WAS RD 005	5	WASHER, ROUND, 2 INCH, FOR 3/4 IN. DIA. BOLT
8	WAS SP 002	2	WASHER, SPRING, DOUBLE HELIX, FOR 3/4 IN. DIA. BOLT
9	WAS SF 003	2	WASHER, SQUARE, FLAT, 3 IN., FOR 3/4 IN. DIA. BOLT

P7-1

SLACKSPAN DEADEND

OPTIONS: 2, 1/0, 3/0, 336, 636

BOLT PLATE: NONE

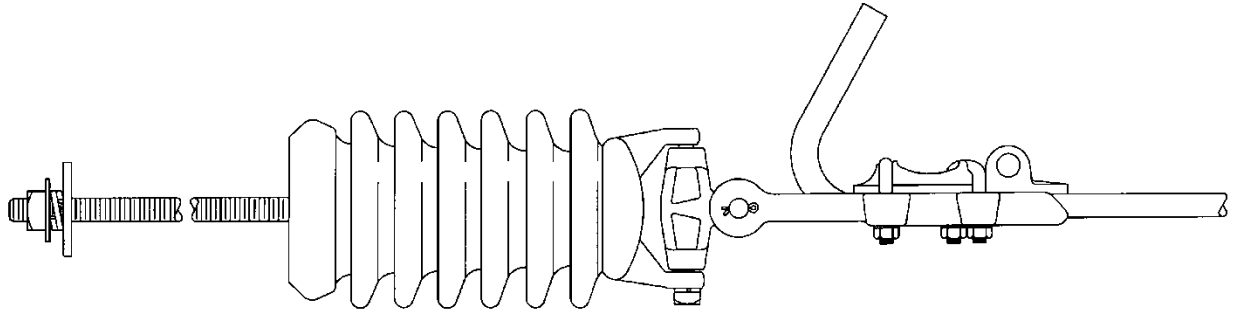

NO.	ITEM ID	QTY	DESCRIPTION
1	ADP TU 001	1	ADAPTER, TRUNION - SLACK SPANNING
2	BOL DA 015	1	BOLT, DOUBLE ARMING, 3/4X14
3	CLA SS ***	1	GENERAL CODE FOR STRAIGHT STRAIN CLAMP
4	INS VP 002	1	INSULATOR, POST 34.5KV CLAMP
5	WAS RD 005	1	WASHER, ROUND, 2 INCH, FOR 3/4 IN. DIA. BOLT
6	WAS SP 002	1	WASHER, SPRING, DOUBLE HELIX, FOR 3/4 IN. DIA. BOLT
7	WAS SF 003	1	WASHER, SQUARE, FLAT, 3 IN., FOR 3/4 IN. DIA. BOLT

P8

10 TO 30 DEGREE ANGLE - ADDITIONAL CLEARANCE

OPTIONS: 2, 1/0, 3/0, 336, 636

BOLT PLATE: NONE

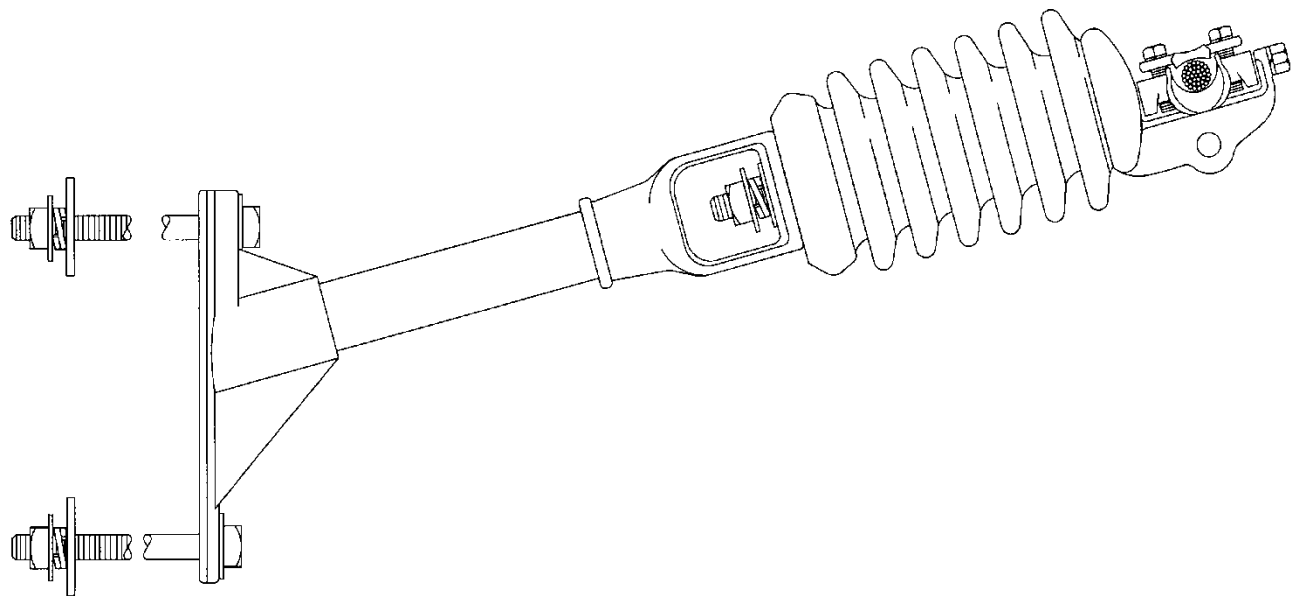

NO.	ITEM ID	QTY	DESCRIPTION
1	BKT FS 001	1	BRACKET, FIBERGLASS STANDOFF, 18 IN.
2	BOL MS 035	2	BOLT, MACHINE, SQUARE HEAD 3/4X12
3	CLA CT ***	1	GENERAL CODE FOR ANGLE CLAMP
4	GUA LI ***	1	GENERAL CODE FOR LINE GUARD
5	INS HP 001	1	INSULATOR, HORIZ. POST 34.5KV CLAMP
6	STU LI 001	1	STUD, LINE POST 3/4 HEAD - 3/4 DIA. X 1-3/4 IN. SHANK
7	WAS RD 005	5	WASHER, ROUND, 2 INCH, FOR 3/4 IN. DIA. BOLT
8	WAS SP 002	2	WASHER, SPRING, DOUBLE HELIX, FOR 3/4 IN. DIA. BOLT
9	WAS SF 003	2	WASHER, SQUARE, FLAT, 3 IN., FOR 3/4 IN. DIA. BOLT

P8-1

0 TO 10 DEGREE ANGLE - ADDITIONAL CLEARANCE

OPTIONS: 2, 1/0, 3/0, 336, 636

BOLT PLATE: NONE

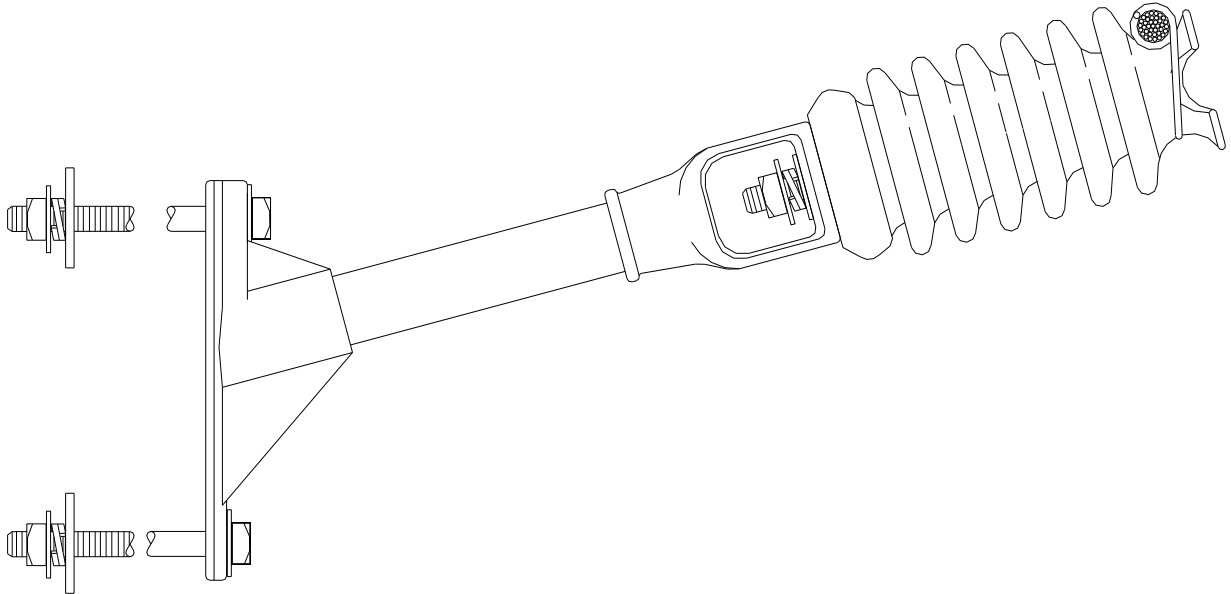

NO.	ITEM ID	QTY	DESCRIPTION
1	BKT FS 001	1	BRACKET, FIBERGLASS STANDOFF, 18 IN.
2	BOL MS 035	2	BOLT, MACHINE, SQUARE HEAD 3/4X12
3	INS VP 001	1	INSULATOR, POST 34.5KV
4	STU LI 001	1	STUD, LINE POST 3/4 HEAD - 3/4 DIA. X 1-3/4 IN. SHANK
5	TIE PR ***	1	GENERAL CODE FOR PREFORMED TIE
6	WAS RD 005	5	WASHER, ROUND, 2 INCH, FOR 3/4 IN. DIA. BOLT
7	WAS SP 002	2	WASHER, SPRING, DOUBLE HELIX, FOR 3/4 IN. DIA. BOLT
8	WAS SF 003	2	WASHER, SQUARE, FLAT, 3 IN., FOR 3/4 IN. DIA. BOLT

P9

POLE-TOP BRACKET, 0 TO 10 DEGREE ANGLE

OPTIONS: 2, 1/0

BOLT PLATE: NONE

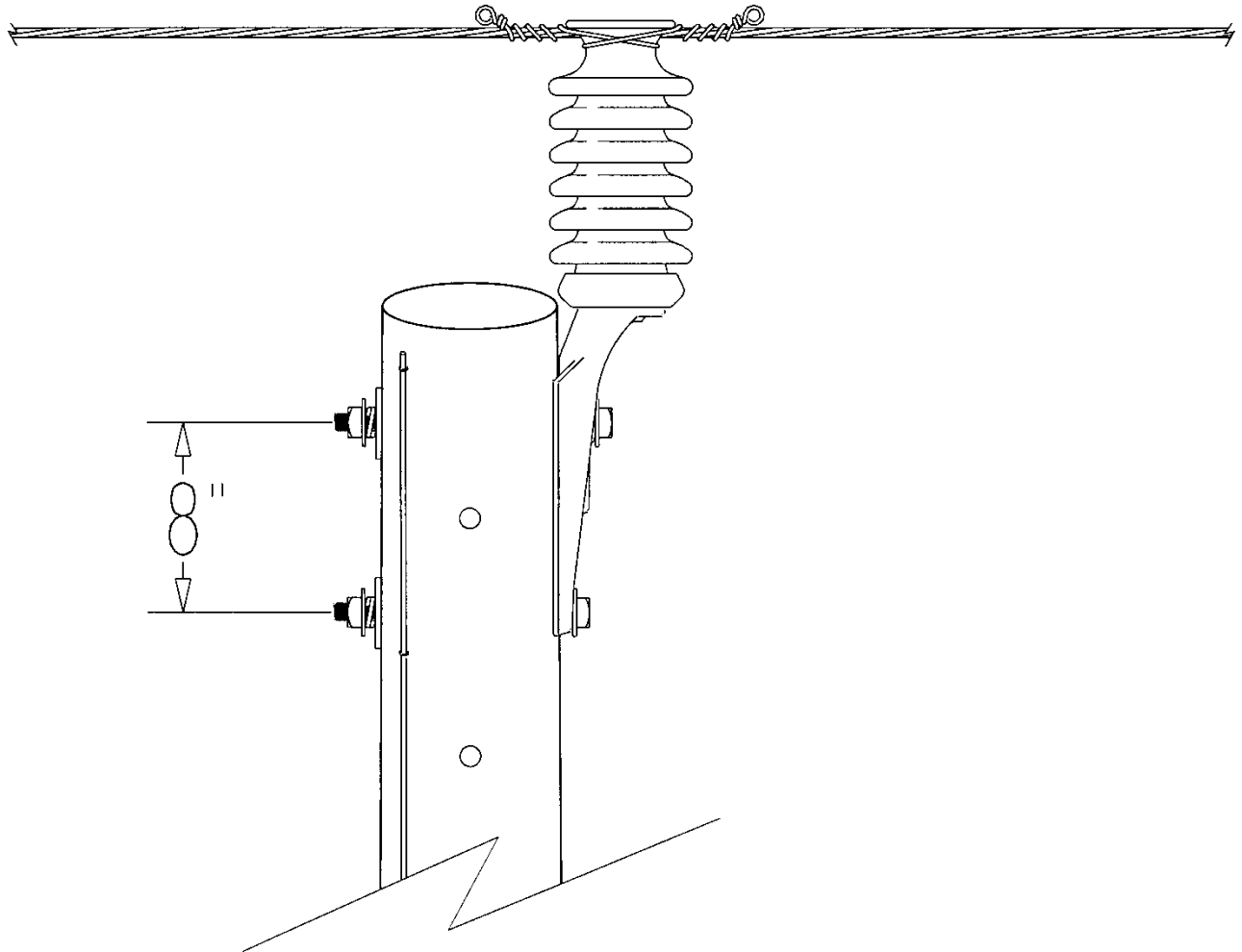

NO.	ITEM ID	QTY	DESCRIPTION
1	BOL MS 035	2	BOLT, MACHINE, SQUARE HEAD 3/4X12
2	BKT IN 005	1	BRACKET, INSULATOR POLETOP
3	COB TW 005	6	CONDUCTOR, #4 SD AL. TIE WIRE
4	INS VP 001	1	INSULATOR, POST 34.5KV
5	STU LI 001	1	STUD, LINE POST 3/4 HEAD - 3/4 DIA. X 1-3/4 IN. SHANK
6	WAS RD 005	5	WASHER, ROUND, 2 INCH, FOR 3/4 IN. DIA. BOLT
7	WAS SP 002	2	WASHER, SPRING, DOUBLE HELIX, FOR 3/4 IN. DIA. BOLT
8	WAS SF 003	2	WASHER, SQUARE, FLAT, 3 IN., FOR 3/4 IN. DIA. BOLT

SH1

0 TO 10 DEGREE ANGLE - TANGENT

OPTIONS: NONE

BOLT PLATE: NONE

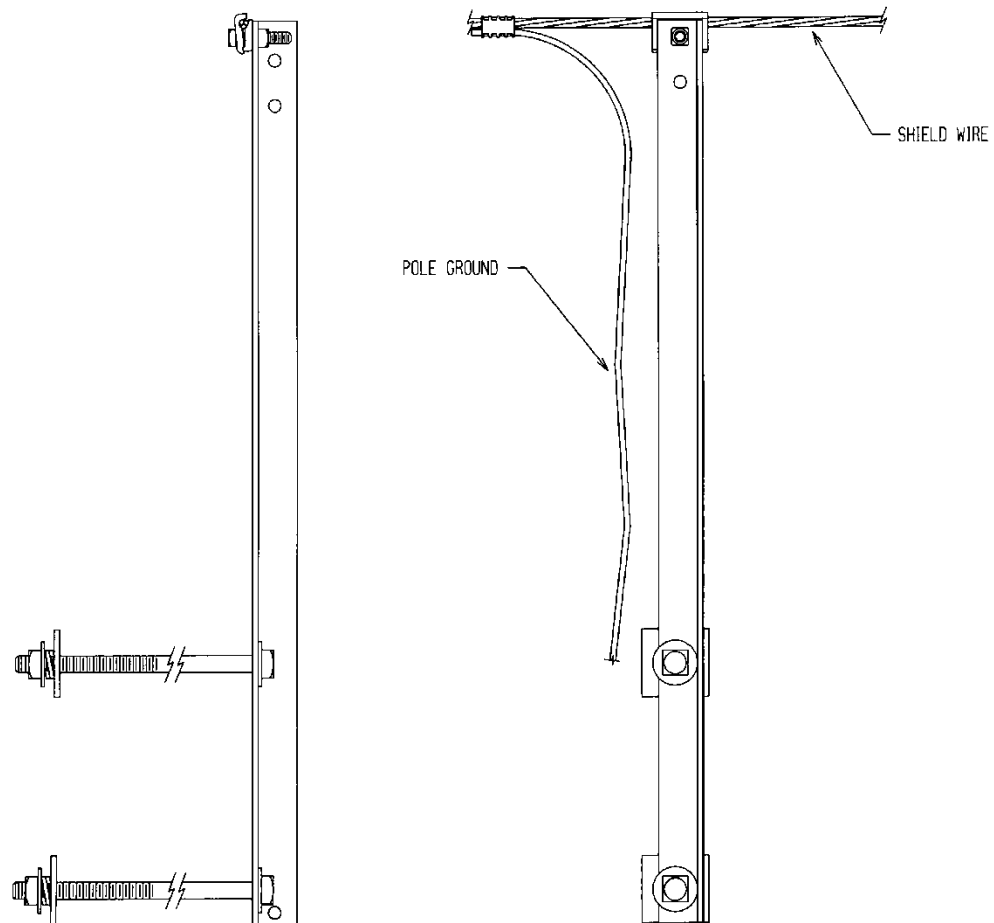

NO.	ITEM ID	QTY	DESCRIPTION
1	BAY SW 004	1	BAYONET, SHIELD WIRE 40 IN. STRAIGHT
2	BOL MS 035	2	BOLT, MACHINE, SQUARE HEAD 3/4X12
3	CLA SW 001	1	CLAMP, SHIELD WIRE 3 NO 6 AW, 3 NO 7 CW
4	WAS RD 005	4	WASHER, ROUND, 2 INCH, FOR 3/4 IN. DIA. BOLT
5	WAS SP 002	2	WASHER, SPRING, DOUBLE HELIX, FOR 3/4 IN. DIA. BOLT
6	WAS SF 003	2	WASHER, SQUARE, FLAT, 3 IN., FOR 3/4 IN. DIA. BOLT

SH2

10 TO 60 DEGREE FLYING ANGLE

OPTIONS: NONE

BOLT PLATE: NONE

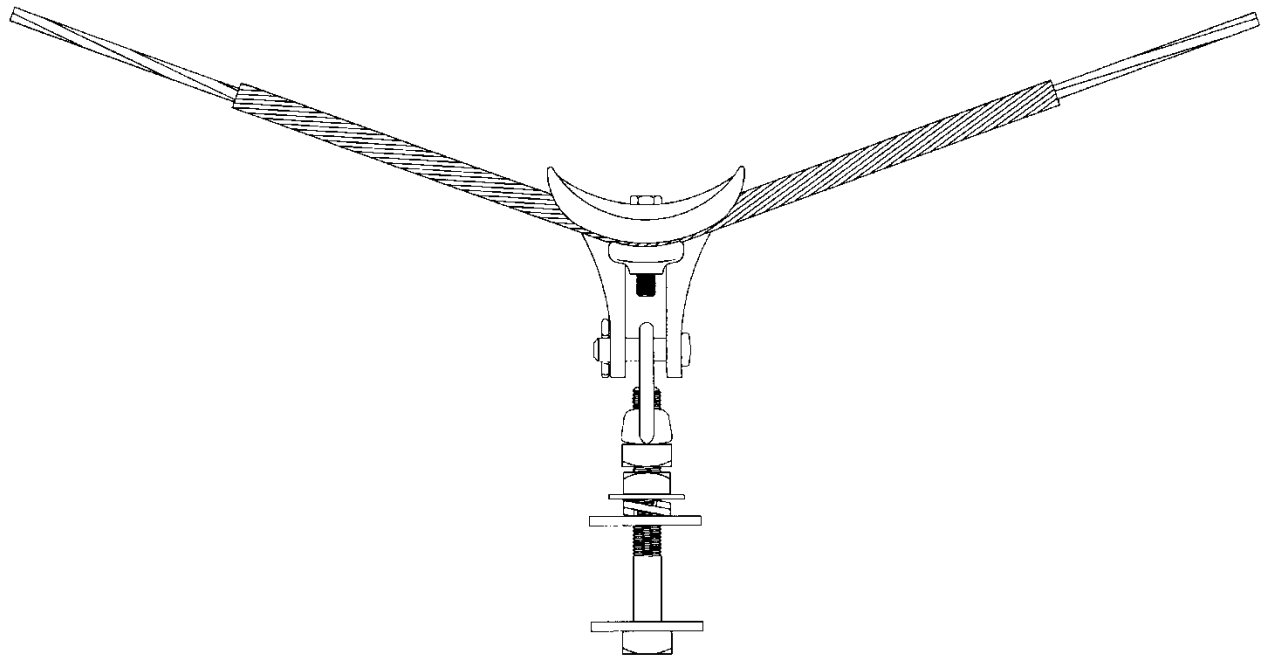

NO.	ITEM ID	QTY	DESCRIPTION
1	BOL MS 035	1	BOLT, MACHINE, SQUARE HEAD 3/4X12
2	CLA AN 001	1	CLAMP, ANGLE 4 SOL. - 250 MCM
3	GUA LI 001	1	LINE GUARD, 3 NO 6 AW
4	NUT EY 003	1	NUT, EYE 3/4
5	WAS RD 005	1	WASHER, ROUND, 2 INCH, FOR 3/4 IN. DIA. BOLT
6	WAS SP 002	1	WASHER, SPRING, DOUBLE HELIX, FOR 3/4 IN. DIA. BOLT
7	WAS SF 003	2	WASHER, SQUARE, FLAT, 3 IN., FOR 3/4 IN. DIA. BOLT

H3

10 TO 60 DEGREE ANGLE

OPTIONS: NONE

BOLT PLATE: NONE

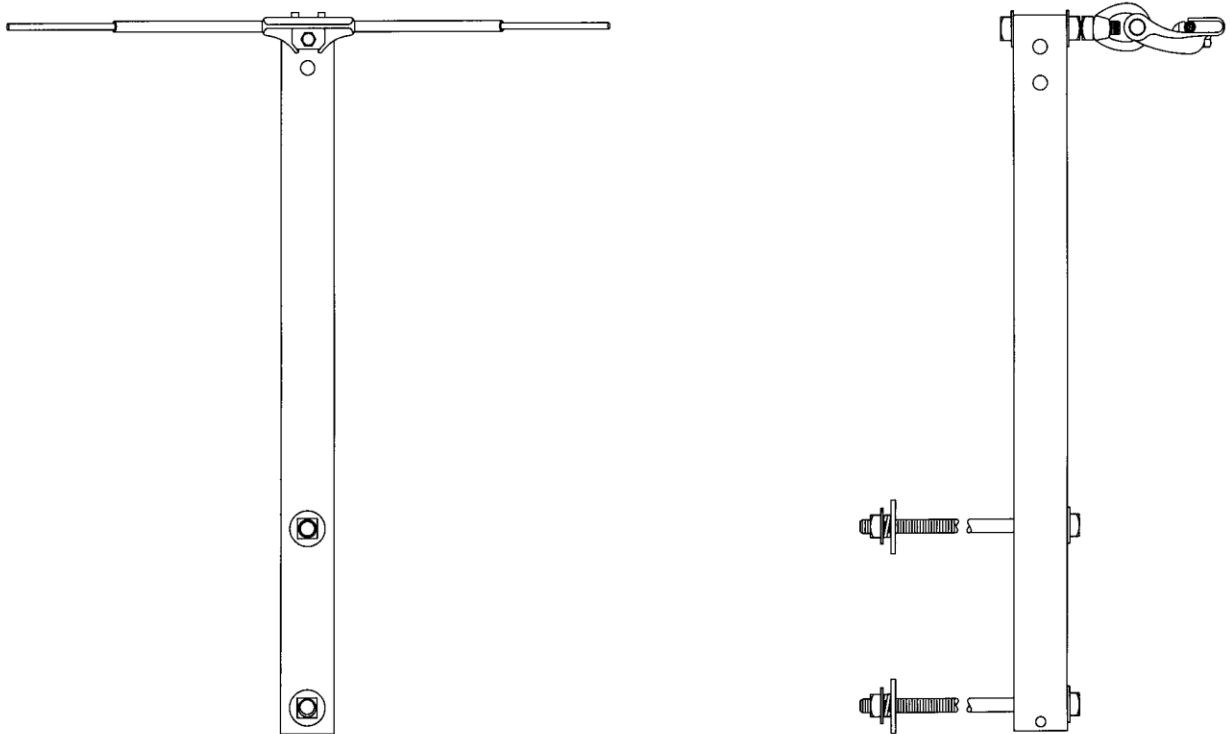

NO.	ITEM ID	QTY	DESCRIPTION
1	BAY SW 003	1	BAYONET, SHIELD WIRE 40 IN. CORNER
2	BOL MS 032	1	BOLT, MACHINE, SQUARE HEAD 3/4X6
3	BOL MS 036	2	BOLT, MACHINE, SQUARE HEAD 3/4X14
4	CLA AN 001	1	CLAMP, ANGLE 4 SOL. - 250 MCM
5	GUA LI 001	1	LINE GUARD, 3 NO 6 AW
6	NUT SL 004	1	LOCKNUT, SQUARE M-F 3/4
7	NUT EY 003	1	NUT, EYE 3/4
8	WAS RD 005	6	WASHER, ROUND, 2 INCH, FOR 3/4 IN. DIA. BOLT
9	WAS SP 002	2	WASHER, SPRING, DOUBLE HELIX, FOR 3/4 IN. DIA. BOLT
10	WAS SF 003	2	WASHER, SQUARE, FLAT, 3 IN., FOR 3/4 IN. DIA. BOLT

SH4

60 TO 90 DEGREE ANGLE - CORNER

OPTIONS: NONE

BOLT PLATE: NONE

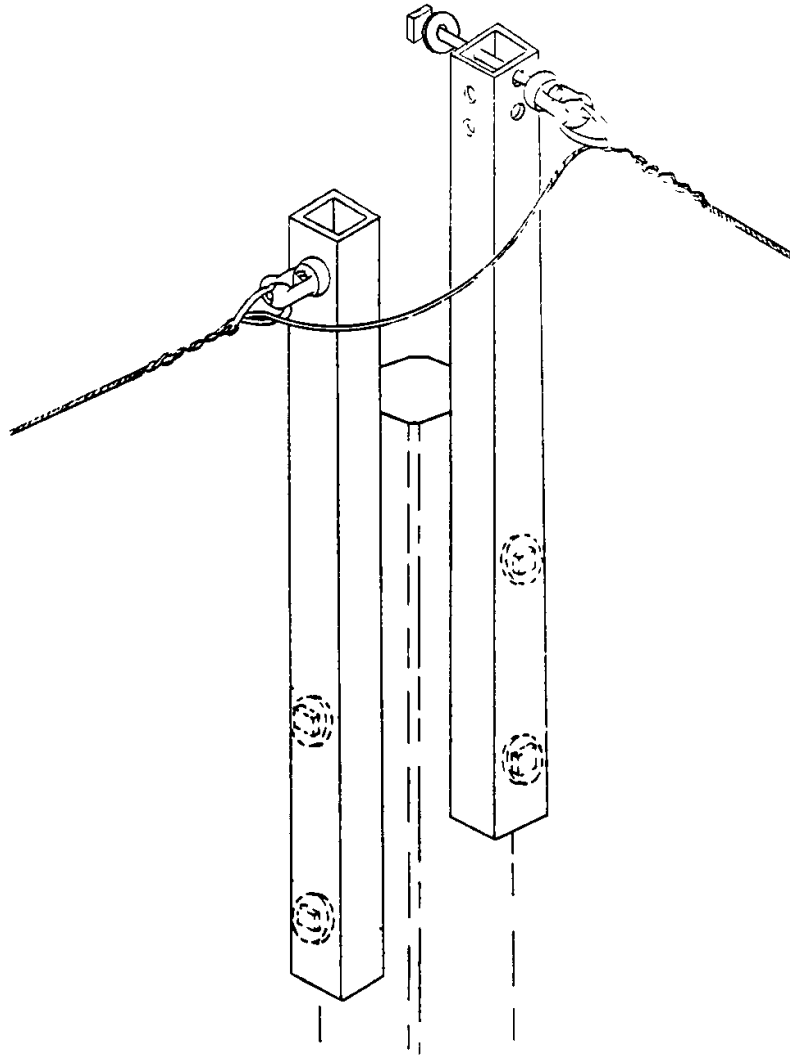

NO.	ITEM ID	QTY	DESCRIPTION
1	BAY SW 003	2	BAYONET, SHIELD WIRE 40 IN. CORNER
2	BOL MS 032	2	BOLT, MACHINE, SQUARE HEAD 3/4X6
3	BOL MS 036	4	BOLT, MACHINE, SQUARE HEAD 3/4X14
4	GRI PR 001	2	GRIP, PREFORMED DEADEND 3 NO 6 AW
5	NUT SL 004	2	LOCKNUT, SQUARE M-F 3/4
6	THI EY 001	2	THIMBLE EYE, 3/4
7	WAS RD 005	10	WASHER, ROUND, 2 INCH, FOR 3/4 IN. DIA. BOLT
8	WAS SP 002	4	WASHER, SPRING, DOUBLE HELIX, FOR 3/4 IN. DIA. BOLT
9	WAS SF 003	4	WASHER, SQUARE, FLAT, 3 IN., FOR 3/4 IN. DIA. BOLT

SH5

DEADEND

OPTIONS: NONE

BOLT PLATE: NONE

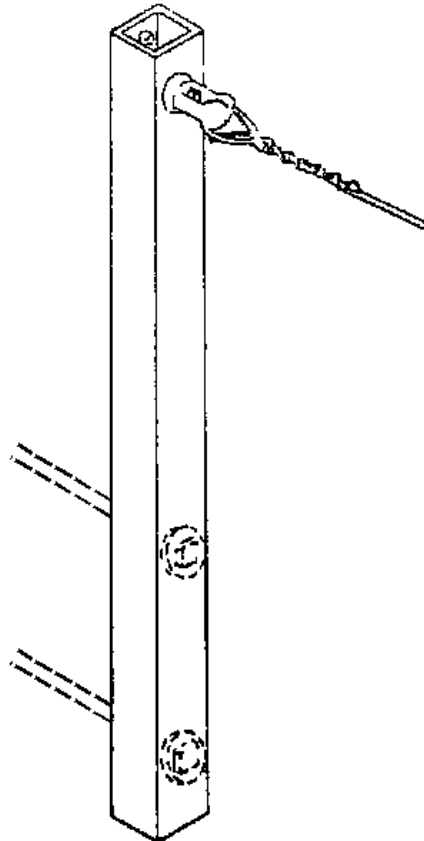

NO.	ITEM ID	QTY	DESCRIPTION
1	BAY SW 003	1	BAYONET, SHIELD WIRE 40 IN. CORNER
2	BOL MS 032	1	BOLT, MACHINE, SQUARE HEAD 3/4X6
3	BOL MS 036	2	BOLT, MACHINE, SQUARE HEAD 3/4X14
4	GRI PR 001	1	GRIP, PREFORMED DEADEND 3 NO 6 AW
5	NUT SL 004	1	LOCKNUT, SQUARE M-F 3/4
6	THI EY 001	1	THIMBLE EYE, 3/4
7	WAS RD 005	5	WASHER, ROUND, 2 INCH, FOR 3/4 IN. DIA. BOLT
8	WAS SP 002	2	WASHER, SPRING, DOUBLE HELIX, FOR 3/4 IN. DIA. BOLT
9	WAS SF 003	2	WASHER, SQUARE, FLAT, 3 IN., FOR 3/4 IN. DIA. BOLT

SH6

CORNER DEADEND/EXTENSION

OPTIONS: NONE

BOLT PLATE: NONE

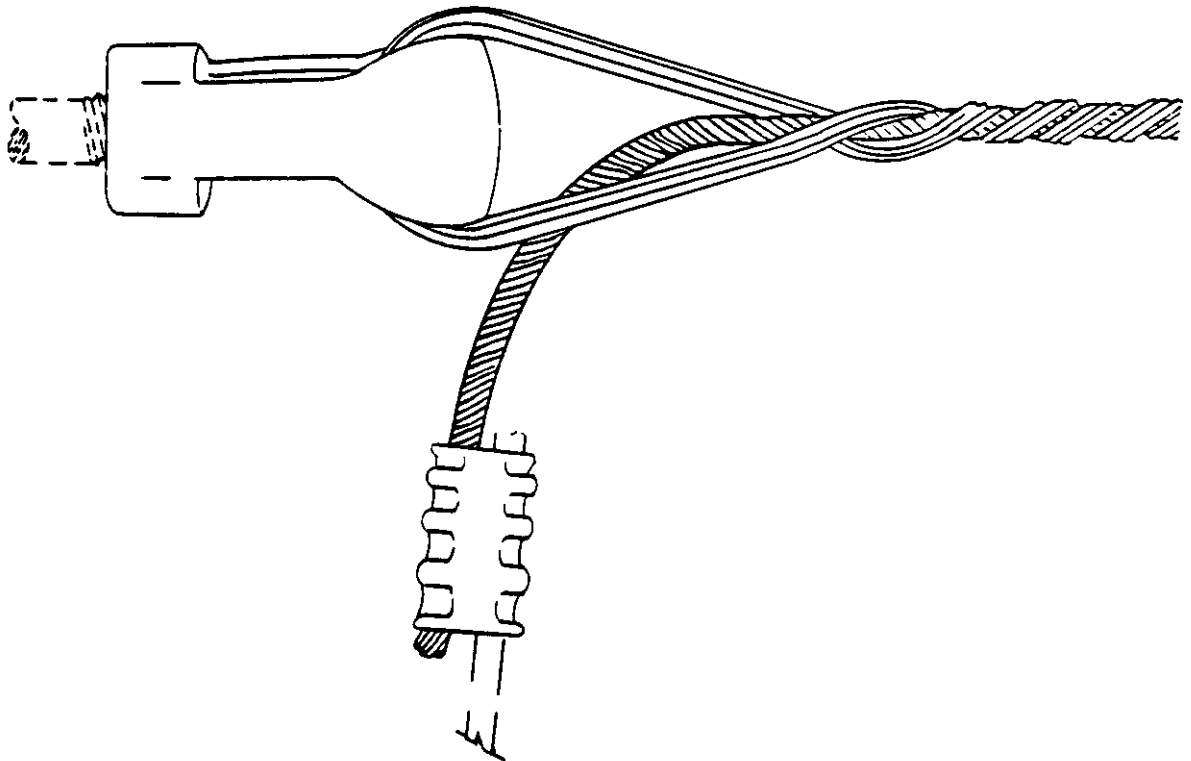

NO.	ITEM ID	QTY	DESCRIPTION
1	CNN CP 003	1	CONNECTOR, AL. COMP. SIDE-BY 2-2/0 2-2/0
2	GRI PR 001	1	GRIP, PREFORMED DEADEND 3 NO 6 AW
3	NUT TE 002	1	THIMBLE EYENUT, 3/4

SH8

DOUBLE DEADEND/ SLACKSPAN

OPTIONS: NONE

BOLT PLATE: NONE

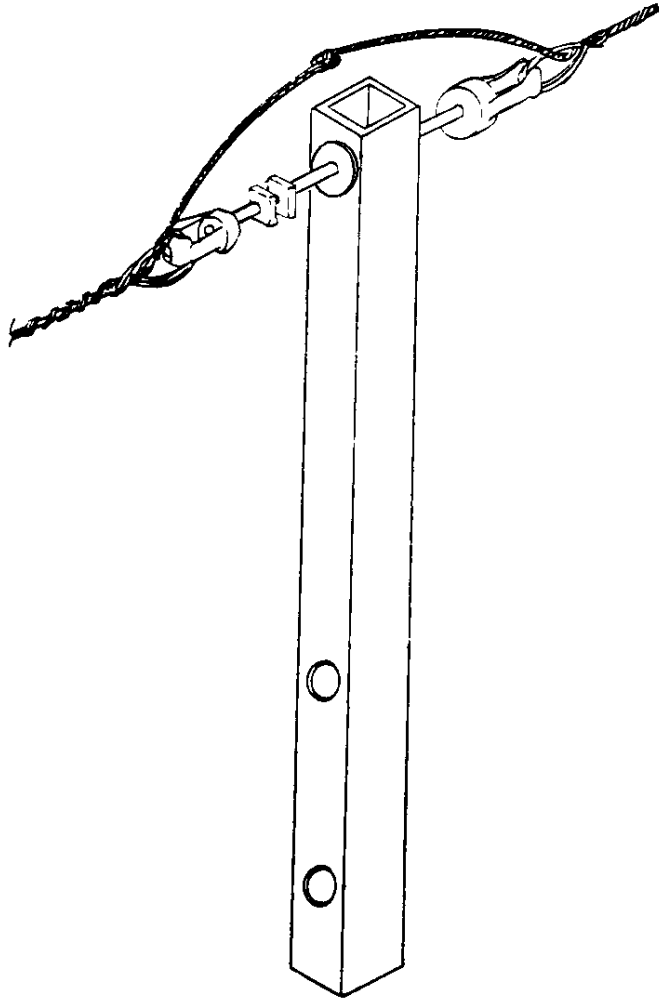

NO.	ITEM ID	QTY	DESCRIPTION
1	BAY SW 003	1	BAYONET, SHIELD WIRE 40 IN. CORNER
2	BOL MS 032	1	BOLT, MACHINE, SQUARE HEAD 3/4X6
3	BOL MS 036	2	BOLT, MACHINE, SQUARE HEAD 3/4X14
4	CNN CP 003	1	CONNECTOR, AL. COMP. SIDE-BY 2-2/0 2-2/0
5	GRI PR 001	2	GRIP, PREFORMED DEADEND 3 NO 6 AW
6	NUT SL 004	1	LOCKNUT, SQUARE M-F 3/4
7	NUT TE 002	1	NUT, THIMBLEYE 3/4 SINGLE EYE
8	THI EY 001	1	THIMBLE EYENUT, 3/4
9	WAS RD 005	5	WASHER, ROUND, 2 INCH, FOR 3/4 IN. DIA. BOLT
10	WAS SP 002	2	WASHER, SPRING, DOUBLE HELIX, FOR 3/4 IN. DIA. BOLT
11	WAS SF 003	2	WASHER, SQUARE, FLAT, 3 IN., FOR 3/4 IN. DIA. BOLT

SH20

TANGENT AND TAP

OPTIONS: NONE

BOLT PLATE: NONE

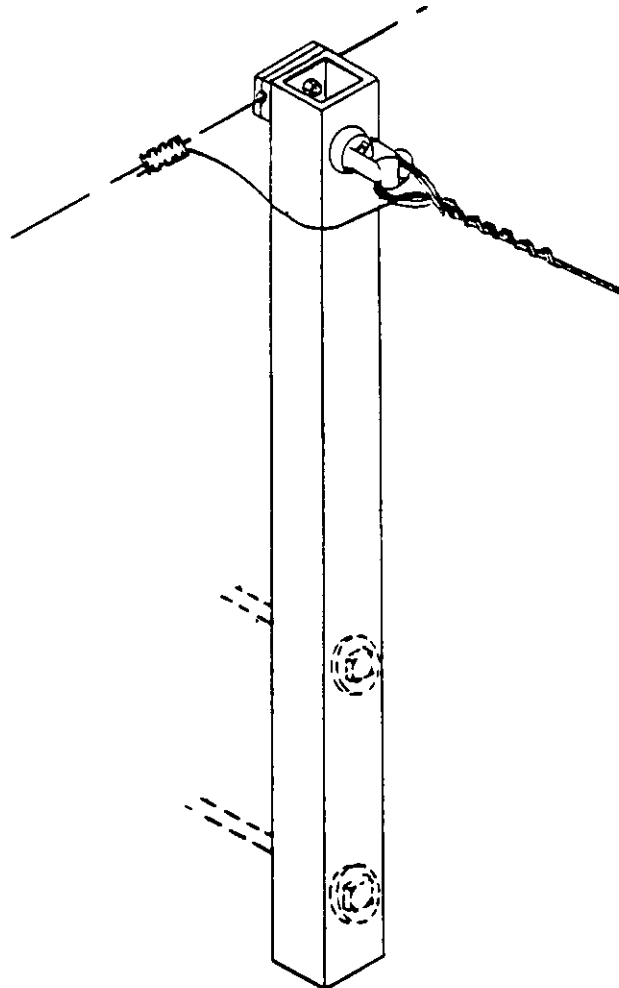

NO.	ITEM ID	QTY	DESCRIPTION
1	BAY SW 003	1	BAYONET, SHIELD WIRE 40 IN. CORNER
2	BOL MS 032	1	BOLT, MACHINE, SQUARE HEAD 3/4X6
3	BOL MS 036	2	BOLT, MACHINE, SQUARE HEAD 3/4X14
4	CLA SW 001	1	CLAMP, SHIELD WIRE 3 NO 6 AW, 3 NO 7 CW
5	CNN CP 003	1	CONNECTOR, AL. COMP. SIDE-BY 2-2/0 2-2/0
6	GRI PR 001	1	GRIP, PREFORMED DEADEND 3 NO 6 AW
7	NUT SL 004	1	LOCKNUT, SQUARE M-F 3/4
8	THI EY 001	1	THIMBLE EYE, 3/4
9	WAS RD 005	5	WASHER, ROUND, 2 INCH, FOR 3/4 IN. DIA. BOLT
10	WAS SP 002	2	WASHER, SPRING, DOUBLE HELIX, FOR 3/4 IN. DIA. BOLT
11	WAS SF 003	2	WASHER, SQUARE, FLAT, 3 IN., FOR 3/4 IN. DIA. BOLT

SH21

CROSS

OPTIONS: NONE

BOLT PLATE: NONE

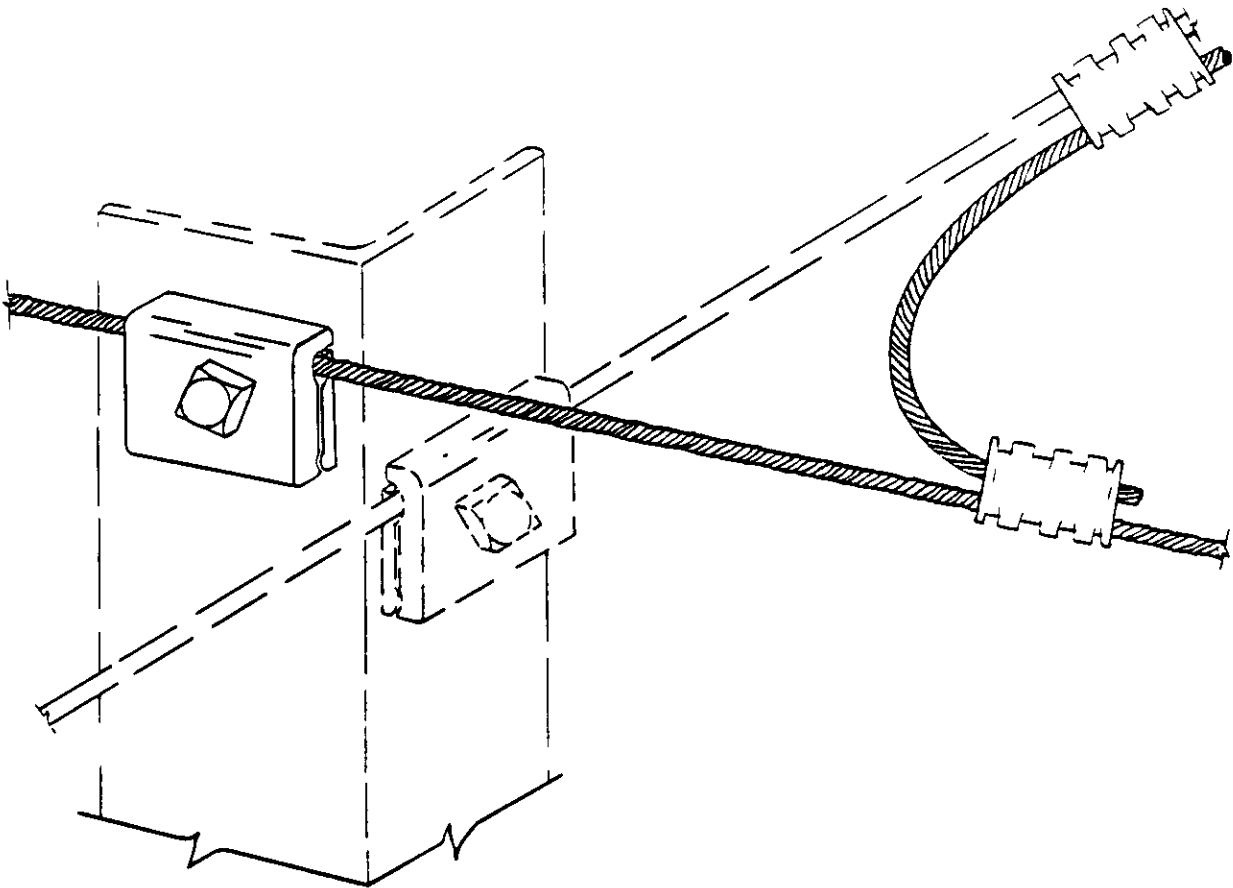

NO.	ITEM ID	QTY	DESCRIPTION
1	CLA SW 001	1	CLAMP, SHIELD WIRE 3 NO 6 AW, 3 NO 7 CW
2	COB AS 005	2	CONDUCTOR, 3 NO 6 AW
3	CNN CP 003	2	CONNECTOR, AL. COMP. SIDE-BY 2-2/0 2-2/0

SH30

SPLIT BOLT ASSEMBLY

OPTIONS: NONE

BOLT PLATE: NONE

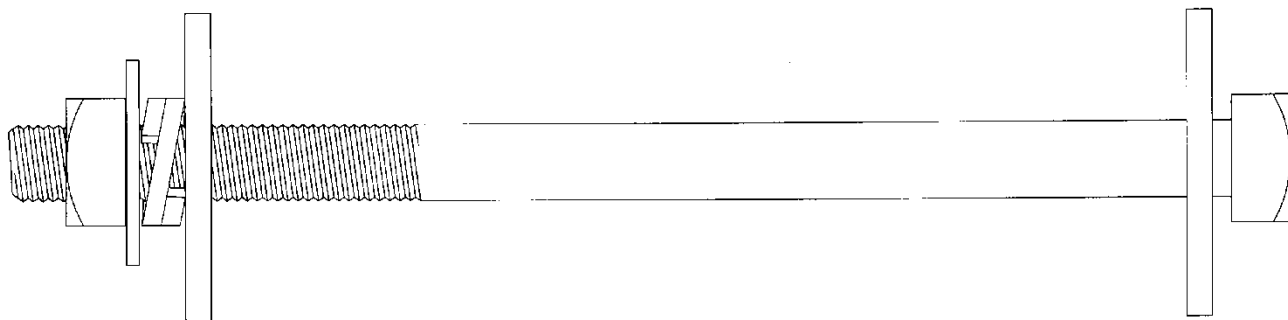

NO.	ITEM ID	QTY	DESCRIPTION
1	BOL MS 035	1	BOLT, MACHINE, SQUARE HEAD 3/4X12
2	WAS RD 005	1	WASHER, ROUND, 2 INCH, FOR 3/4 IN. DIA. BOLT
3	WAS SP 002	1	WASHER, SPRING, DOUBLE HELIX, FOR 3/4 IN. DIA. BOLT
4	WAS SF 003	2	WASHER, SQUARE, FLAT, 3 IN., FOR 3/4 IN. DIA. BOLT