

DIRECT BURIED DUCT BANK

CONSTRUCTION NOTES

I. GENERAL

The work under this section consists of assembling single ducts or multiple duct conduit in spacers and backfilling and compacting the ducts to 6" above the top of the duct or duct bank.

II. APPLICATION

Direct Buried Duct Bank

III. MATERIAL

Four or six inch Schedule 40 Polyvinyl Chloride (PVC) conduit is required.

III.1. DUCT:

Four or six inch Schedule 40 Polyvinyl Chloride (PVC) conduit.

III.2. SPACERS:

Standard issue Duct Spacers, providing 1-1/2" inches clearance between ducts will be used.

III.3. BACKFILL:

Select backfill shall be used (optional Flo-fill)

IV. DUCT LAYING

IV.1. Unless a base course is specified, duct shall be laid on a three (3) inch layer of compacted backfill or Flo-fill material. Individual ducts shall be fully surrounded by a minimum of three (3) inches of backfill or Flo-fill material on the bottom and sides and 6 inches on top. Ducts in multiple duct buried conduit shall be separated by 1-1/2 inches and be completely surrounded by backfill or Flo-fill material.

IV.2. Duct shall be joined in accordance with manufacturer's specifications. Joints for adjacent ducts in the same horizontal layer as well as joints in the vertical rows should be staggered by about six (6) inches.

V. DUCT ALIGNMENT

Schedule 40 Polyvinyl Chloride (PVC) conduit is sufficiently flexible to allow it to conform to minor changes in trench direction or elevation. Any other bends shall be made using pre-formed sweeps. PVC 5 degree Bend couplings will not be used.

VI. BACKFILLING

The backfill or Flo-fill surrounding the duct(s) shall be compacted in accordance with the manufacturer's recommendations. Such backfill shall extend to 6" above the top of the duct of ducts. Above that level backfill and compaction shall be carried out as specified under Excavation, Backfill, & Compaction Paragraphs, of the Earthwork Section.

VII. MARKING TAPE

Marking tape shall be installed on both sides of the bottom of the trench, on each side of each layer of duct and in the center and on each side of the trench six (6) inches below the surface or just below the pavement base.

VIII. MINIMUM COVER REQUIREMENTS

In state Right-of-Ways the minimum vertical clearance is 36" below top of pavement or 30" below the existing ground. Not closer than two feet behind curb and if buried under sidewalk or bike path the minimum depth is 18 inches (NESC). The 18" minimum depth under sidewalk may be reduced 6" for each 2" of concrete or equivalent above the conductors. Areas subject to heavy vehicular traffic such as driveways or parking areas shall have a minimum cover of 24 inches.

DB- / - DIRECT BURIED DUCT BANK

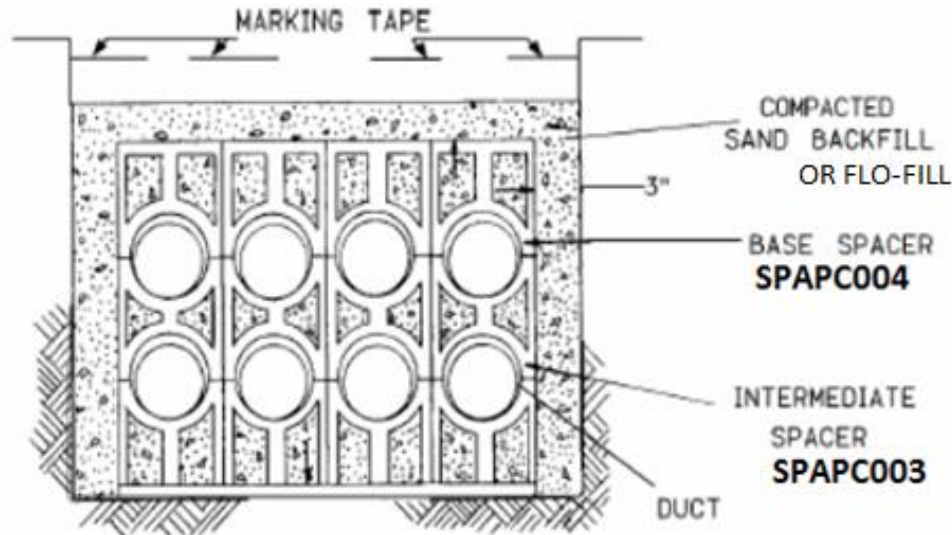

EXAMPLE: DB-2/4-

DIRECT BURIED DUCT BANK

PLATE	DESCRIPTION	DUCT SIZE	DUCTS HIGH	DUCTS WIDE
DB-2/4-4	DUCT BANK, DIRECT BURIED	4"	2	4
DB-2/5-4	DUCT BANK, DIRECT BURIED	4"	2	5
DB-2/3-4	DUCT BANK, DIRECT BURIED	4"	2	3
DB-2/2-4	DUCT BANK, DIRECT BURIED	4"	2	2
DB-3/3-4	DUCT BANK, DIRECT BURIED	4"	3	3
DB-2/4-6	DUCT BANK, DIRECT BURIED	6"	2	4
DB-2/5-6	DUCT BANK, DIRECT BURIED	6"	2	5
DB-2/3-6	DUCT BANK, DIRECT BURIED	6"	2	3
DB-2/2-6	DUCT BANK, DIRECT BURIED	6"	2	2
DB-3/3-6	DUCT BANK, DIRECT BURIED	6"	3	3

NOTE:

Unit of measure for this plate is 10 linear feet. Each plate provides all schedule 40 polyvinyl chloride (PVC) conduit and spacers to build 10 linear feet of the designated duct bank.

THIS PAGE INTENTIONALLY LEFT BLANK