

k

JEA Water and Wastewater Approved Materials Manual

VOLUME III

January 1, 2021 – Edition

“Foundation for the Future – Water & Wastewater Standards”

Table of Contents

WATER & RECLAIMED WATER APPROVED MATERIALS 9

PIPE..... 10

 AW-101: DUCTILE IRON PIPE 10

 AW-102: PVC PIPE (DR14 & DR18)..... 11

 AW-103: PVC PIPE (SDR-21) 12

 AW-104: PVC PIPE (SCH 40 & SCH 80) 13

 AW-105: POLYETHYLENE TUBING 14

 AW-106: GALVANIZED PIPE..... 15

 AW-107: HDPE PIPE 16

FITTINGS 17

 AW-201: DUCTILE IRON FITTING..... 17

 AW-202: IRON TAPPING SLEEVE 18

 AW-203: STAINLESS STEEL TAPPING SLEEVE 19

 AW-204: PVC SOLVENT WELD FITTING 20

 AW-205: SDR 21 PUSH ON JOINT FITTING 21

 AW-206: PVC PRESSURE FITTING..... 22

VALVES, HYDRANTS 23

 AW-301: VALVE BOX AND COVER..... 23

 AW-302: GATE VALVE 24

 AW-303: CONTROL VALVE 25

 AW-304: TAPPING VALVE..... 26

 AW-305: CORPORATION STOP..... 27

 AW-306: INSERTION VALVE 28

 AW-307: CURB STOP 29

 AW-308: FIRE HYDRANT..... 30

SERVICE PIPE ACCESSORIES..... 31

AW-401: BOLTLESS COUPLING.....	31
AW-402: BRASS ADAPTER & COUPLER	32
AW-403: SERVICE SADDLE, DOUBLE STRAP	33
AW-404: SERVICE SADDLE, SINGLE STRAP	34
AW-405: PAIR ADAPTORS	35
AW-406: METER BOX	36
AW-407: METER.....	36
LARGE PIPE ACCESSORIES	37
AW-501: CAST COUPLING	37
AW-502: FULL CIRCLE REPAIR CLAMP.....	38
AW-503: ACCESSORY PACK.....	39
AW-504: RESTRAINTS FOR PVC & D.I. PIPE.....	40
AW-505: PVC & D.I. BELL RESTRAINING DEVICE	41
AW-506: MECHANICAL JOINT FASTENERS.....	42
AW-507: FLANGE ADAPTER	43
AW-508: CASING SPACER.....	44
LOCATE WIRE.....	45
AW-601: LOCATE WIRE	45
AW-602: DIRECT BURY LUG	46
AW-603: LOCATE WIRE TESTING EQUIPMENT.....	47
MISC MATERIALS	48
AW-701: ADMIXTURES.....	48
AW-702: METALWORK FINISHES	49
AW-703: METER.....	49
WASTEWATER APPROVED MATERIALS.....	50
PIPE.....	51
AS-101: HDPE PIPE	51
AS-102: PVC PRESSURE (DR18) PIPE	52
AS-103: PVC GRAVITY PIPE.....	53

AS-104: PVC PIPE (SCH 40 & SCH 80)	54
AS-105: FIBERGLASS REINFORCED POLYMER MORTAR PIPE	55
FITTINGS	56
AS-201: DUCTILE IRON FITTINGS.....	56
AS-202: STAINLESS STEEL TAPPING SLEEVE	57
AS-203: PVC SOLVENT WELD FITTING.....	58
AS-204: PVC GRAVITY FITTING (SDR26)	59
AS-205: PVC PRESSURE FITTING.....	60
VALVES	61
AS-301: VALVE BOX AND COVER.....	61
AS-302: GATE VALVE	62
AS-303: TAPPING VALVE	63
AS-304: PLUG VALVE	64
AS-305: CHECK VALVE	65
AS-306: AIR VALVE	66
AS-307: INSERTION VALVE	67
PIPE ACCESSORIES	68
AS-401: FULL CIRCLE 2" TAPPING SADDLE FOR ARVS.....	68
AS-402: RESTRAINTS FOR PVC OR D.I. PIPE	69
AS-403: PVC OR D.I. BELL RESTRAINING DEVICE.....	70
AS-404: ACCESSORY PACK.....	71
AS-405: MECHANICAL JOINT FASTENER	72
AS-406: FLANGE ADAPTER	73
AS-407: CASING SPACER	74
AS-408: PIPE COUPLING	75
AS-409: FULL CIRCLE REPAIR CLAMP	76
MANHOLES	77
AS-501: MANHOLE AND ACCESSORIES	77
AS-502: PROTECTIVE COATING	78
AS-503: MANHOLE ADJUSTMENT RING.....	79

AS-504: MANHOLE FRAME AND COVER	80
AS-505: MANHOLE MONITOR.....	81
PUMP STATIONS	82
AS-601: ALUMINUM HATCH (FRAME AND COVER)	82
AS-602: CONCRETE LINER	83
AS-603: WASTEWATER PUMP.....	84
AS-604: ELECTRICAL, CONTROL PANEL, VFD & SCADA	85
AS-605: EMERGENCY PUMP ENGINE	86
VACUUM SYSTEM	87
AS-701: VACUUM SEWER VALVE	87
LOCATE WIRE	88
AS-801: LOCATE WIRE	88
AS-802: DIRECT BURY LUG	89
AS-803: LOCATE WIRE TESTING EQUIPMENT	90
MISC MATERIALS	91
AS-901: ADMIXTURES	91
AS-902: METALWORK FINISH.....	92
WASTEWATER TREATMENT PLANT APPROVED MATERIALS	93
PROTECTIVE COATING	94
WWT-101: PROTECTIVE COATING	94
ELECTRICAL, CONTROL PANEL, VFD & SCADA	95
WWT-201: ELECTRICAL CONTROL PANEL	95
WWT-202: SCADA SYSTEM INTEGRATION.....	96
WWT-203: VARIABLE FREQUENCY DRIVES	97
SCREENS	98
WWT-301: WWTP SCREENS.....	98
UV SYSTEMS	99
WWT-401: UV DISINFECTION EQUIPMENT.....	99

ODOR CONTROL..... 100
 WWT-402: ODOR CONTROL..... 100

GATES 101
 WWT-501: SLUICE/SLIDE GATES 101
 FLOOD GATES: LIMIT STAINLESS STEEL FLOOD GATES TO 2’ AND SMALLER..... 101

AIR SCRUBBERS..... 102
 WWT-601: PLANT AIR SYSTEM 102
 WWT-602: AIR FILTRATION CARBON 103

TANKS 104
 WWT-701: FLAT ALUMINUM TANK COVERS 104
 WWT-702: GLASS FUSED/STEEL TANKS 105
 WWT-703: PRESTRESS STORAGE TANKS..... 106
 WWT-704: FUEL TANKS..... 107
 WWT-705: LINERS FOR CORROSION PROTECTION 108

EFFLUENT FILTERS..... 109
 WWT-801: CLOTH DISK FILTERS..... 109

CENTRIFUGES..... 110
 WWT-901: CENTRIFUGES..... 110

AERATION DIFFUSERS 111
 WWT-1001: FINE BUBBLE DIFFUSERS..... 111

VALVE ACTUATORS 112
 WWT-1101: ACTUATOR 112
 CHEMICAL FEED SKIDS 113
 WWT-1201: CHEMICAL METERING FEED PUMP SKID 113

FLOW METERS 114
 WWT-1301: MAGNETIC FLOW METERS..... 114
 WWT-1302: ULTRASONIC FLOW METERS..... 115

PUMPS..... 116
 WWT-1401: CHEMICAL METERING PUMPS..... 116



WWT-1402: RECYCLE/EFFLUENT PUMPS..... 117

WWT-1403: GRINDER PUMPS..... 118

WWT-1404: REUSE VERTICAL TURBINE PUMPS 119

WWT-1405: SELF-PRIMING RAW SEWAGE PUMPS 120

WWT-1406: PROGRESSIVE CAVITY PUMPS..... 121

WWT-1407: VACUUM PUMP 122

VALVES 123

 WWT-1501: PLUG VALVES 123

 WWT-1502: CHECK VALVES 124

 WWT-1503: BALL VALVES 125

VALVE POSITION MONITOR 126

 WWT-1601: ROTARY POSITION MONITOR 126

CONVEYOR..... 127

 WWT-1701: CONVEYOR SYSTEM..... 127

INSTRUMENTATION..... 128

 GENERAL 128

 APPROVED MANUFACTURERS..... 129

 ANALYZERS..... 130

 CONTROLLERS..... 131

 PROBES..... 132

 SAMPLERS 133

 SENSORS..... 134

 TRANSMITTERS 135

WATER TREATMENT PLANT APPROVED MATERIALS..... 136

PROTECTIVE COATINGS..... 137

 WT-101: PROTECTIVE COATING..... 137

OIL 138

 WT-201: OIL 138

SLEEVE BEARINGS AND MECHANICAL SEALS..... 139



WT-301: SLEEVE BEARINGS..... 139

WT-302: MECHANICAL SEALS 140

PUMPS..... 141

WT-401: PUMPS..... 141

ELECTRICAL-ELECTRONICS-INSTRUMENTATION..... 142

WT-501: ELECTRICAL EQUIPMENT..... 142

WT-502: INSTRUMENTATION EQUIPMENT 143

WT-503: ELECTRONIC EQUIPMENT..... 145

STORAGE TANKS 147

WT-601: STORAGE TANKS..... 147

FANS 148

WT-701: FANS AND INTAKE HOOD 148

FLOW METERS 149

WT-801: FLOW METERS AND RELATED EQUIPMENT 149

VALVES 150

WT-901: AIR RELEASE/VACUUM VALVES..... 150

WT-902: BALL VALVES..... 151

WT-903: BUTTERFLY VALVES 152

WT-904: CHECK VALVES..... 153

WT-905: GATE VALVES..... 154

WT-906: PRESSURE REGULATING VALVES..... 155

WT-907: MISC. VALVE TYPES 156

MISCELLANEOUS..... 157

WT-1001: MISC MATERIALS..... 157

WATER & RECLAIMED WATER APPROVED MATERIALS

PIPE

AW-101: DUCTILE IRON PIPE



Note: Push on joint shown as example only. (For additional joints, see specifications)

DESCRIPTION: Ductile Iron Pipe (D.I.P), cement lined. See Chapter III.1. - Section 350 of the current JEA Standards for specifications and requirements. See Chapter V.1. - Section 701 for Reclaimed Water specifications and requirements.

SIZE	MANUFACTURER	MODEL #
3-inch & larger	American Cast Iron Pipe Company	N/A
3-inch & larger	McWane Ductile	N/A
3-inch & larger	U.S. Pipe	N/A

AW-102: PVC PIPE (DR14 & DR18)



DESCRIPTION: DR14 & DR18 Pipe. See Chapter III. 1. - Section 350 of the current JEA Standards for specifications and requirements. See Chapter V.1. - Section 701 for Reclaimed Water specifications and requirements.

SIZE	MANUFACTURER	MODEL #
4-inch - 12	Diamond Plastics	N/A
4-inch - 12	JM Eagle	N/A
4-inch - 12	National Pipe & Plastics/National PVC)	N/A
4-inch - 12	North American Pipe Co. (NAPCO)	N/A
4-inch - 12	Ipex	N/A
4-inch - 12	Sanderson Pipe Corporation	N/A
16-inch	Diamond Plastics	N/A
16-inch	JM Eagle	N/A
16-inch	National Pipe & Plastics/National PVC)	N/A
16-inch	North American Pipe Co. (NAPCO)	N/A
16-inch	Ipex	N/A

AW-103: PVC PIPE (SDR-21)



DESCRIPTION: PVC 1120, SDR 21 Pipe. See Chapter III.1. - Section 350 of the current JEA Standards for specifications and requirements. See Chapter V.1. - Section 701 for Reclaimed Water specifications and requirements.

SIZE	MANUFACTURER	MODEL #
2-inch only	Diamond Plastics	N/A
2-inch only	JM Eagle	N/A
2-inch only	North American Pipe Co. (NAPCO)	N/A
4-inch only	National Pipe & Plastics	N/A

AW-104: PVC PIPE (SCH 40 & SCH 80)



DESCRIPTION: PVC SCH 40 & SCH 80 Pipe. See Chapter III.1. - Section 350 of the current JEA Standards for specifications and requirements. See Chapter V.1. - Section 701 for Reclaimed Water specifications and requirements.

SIZE	MANUFACTURER	MODEL #
2-inch only	JM Eagle Manufacturing	N/A
2-inch only	National Pipe and Plastics	N/A
2-inch only	North American Pipe Co. (NAPCO)	N/A
2-inch only	Universal 100 / Accord	N/A
2-inch only	Charlotte Pipe and Foundry Co	N/A

AW-105: POLYETHYLENE TUBING



DESCRIPTION: PE 4710, SDR-9, Copper Tube Size, Polyethylene Tubing. See Chapter III.1. - Section 350 of the current JEA Standards for specifications and requirements. See Chapter V.1. - Section 701 for Reclaimed Water specifications and requirements.

SIZE	MANUFACTURER	MODEL #
2-inch & smaller	Endot-Yardley	EndoPure
2-inch & smaller	Phillips Driscopipe/Performance Pipe	N/A
2-inch & smaller	Charter Plastics	Blue Ice
2-inch & smaller	Silver-Line Plastics	N/A
2-inch & smaller	Advanced Drainage System	ADS PolyFlex

AW-106: GALVANIZED PIPE



Note: For use in Contaminated Soil Sites only.

DESCRIPTION: Galvanized Pipe. See Chapter III.1. - Section 350 of the current JEA Standards for specifications and requirements. See Chapter V.1. - Section 701 for Reclaimed Water specifications and requirements.

SIZE	MANUFACTURER	MODEL #
3-inch & smaller	Grinnell Corporation	N/A
4-inch & smaller	Wheatland Tube	N/A

AW-107: HDPE PIPE



DESCRIPTION: AWWA C906 Polyethylene (PE) Pressure Pipe and Fittings, 4-inch through 63-inch, for Water Distribution American Society for Testing and Materials (ASTM) Standards.

SIZE	MANUFACTURER	MODEL #
4-inch and larger		N/A

FITTINGS

AW-201: DUCTILE IRON FITTING



Note: Mechanical Joint, bend, shown as example only (for additional joints & fittings, see specifications).

DESCRIPTION: Ductile Iron Fitting, cement-lined or JEA approved equal. See Chapter III.1. - Section 350 of the current JEA Standards for specifications and requirements. See Chapter V.1. - Section 701 for Reclaimed Water specifications and requirements.

SIZE	MANUFACTURER	MODEL #
3-inch & larger	Tyler Union	N/A
4-inch & larger	Star Pipe Products	N/A
3-inch & larger	Sigma Corp. (Russell Pipe)	N/A
3-inch & larger	SIP Industries	N/A

AW-202: IRON TAPPING SLEEVE

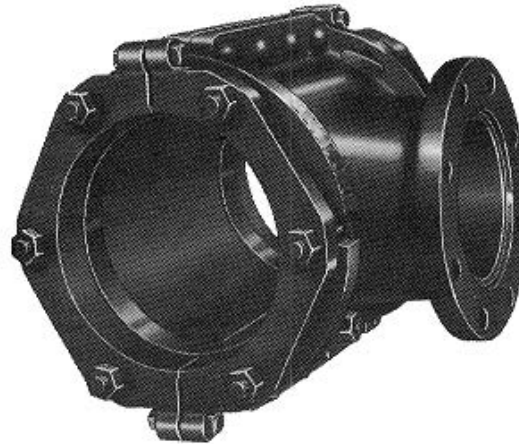

Note: Mechanical Joint Shown as example only (for additional joints, see specifications).

DESCRIPTION: Iron Tapping Sleeve. See Chapter III. 2. - Section 351 of the current JEA Standards for specifications and requirements. See Chapter V.2. – Section 702 for Reclaimed Water specifications and requirements. This sleeve shall not be utilized on PVC pipe larger than 12-inch.

SIZE	MANUFACTURER	MODEL #
4-inch & larger	American Cast Iron Pipe Company	1004
4-inch & larger	Clow Valve	F-5205
4-inch & larger	M & H Valve Company	1574
4-inch & larger	Mueller Company	H-615, H-616, H-619
4-inch & larger	Tyler Union	5-149-CI
4-inch & larger	US Pipe	N/A
30-inch & larger	Smith-Blair (Carbon Steel)	623

AW-203: STAINLESS STEEL TAPPING SLEEVE

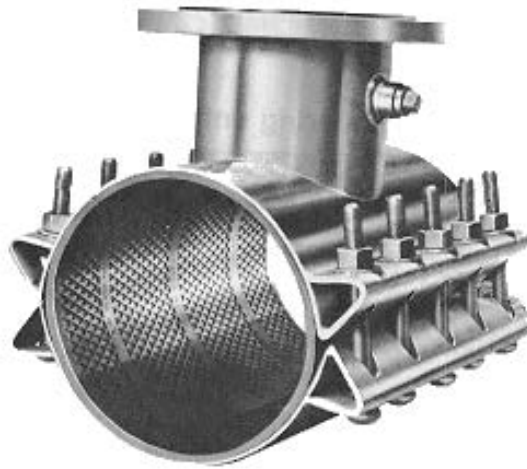

Note: Must be all stainless steel, no dissimilar metals allowed.

DESCRIPTION: Stainless Steel Tapping Sleeve. See Section 351 of the current JEA Standards for specifications and requirements. See Section 702 for Reclaimed Water specifications and requirements.

SIZE	MANUFACTURER	MODEL #
4-inch & larger	Cascade Waterworks Mfg.	CST-EX
4-inch & larger	Dresser Inc./GE	630
4-inch & larger	Ford Meter Box Company	FAST Series, FTSS
4-inch & larger	JCM Industries, Inc.	432, 439, 452 (14-inch and larger)
4-inch & larger	Power Seal	3490, 3490 MJ (8-inch and smaller)
4-inch & larger	Romac Industries, Inc.	SST
4-inch & larger	Smith-Blair	663 & 665
4-inch & larger	Mueller	H304

AW-204: PVC SOLVENT WELD FITTING



DESCRIPTION: Schedule 40 & 80 Solvent Weld Fittings. See Chapter III.1. - Section 350 of the current JEA Standards for specifications and requirements. See Chapter V.1. - Section 701 for Reclaimed Water specifications and requirements.

SIZE	MANUFACTURER	MODEL #
2-inch only	Chemtrol/NIBCO	N/A
2-inch only	Ipex	N/A
2-inch only	Lasco Fittings, Inc.	N/A
2-inch only	Georg Fisher Sloane Manufacturing (GF Piping Systems)	N/A
2-inch only	Spears Manufacturing	N/A
2-inch only	Charlotte Pipe and Foundry Co	N/A

AW-205: SDR 21 PUSH ON JOINT FITTING



DESCRIPTION: PVC 1120, SDR 21 Push On Joint Fittings. See Chapter III.1. - Section 350 of the current JEA Standards for specifications and requirements. See Chapter V.1. - Section 701 for Reclaimed Water specifications and requirements.

SIZE	MANUFACTURER	MODEL #
2-inch	Ipex	N/A

AW-206: PVC PRESSURE FITTING



DESCRIPTION: PVC C900, DR18 Injection Molded, Push on Joint (pressure) Fittings. See Chapter III.1. - Section 350 of the current JEA Standards for specifications and requirements. See Chapter V.1. - Section 701 for Reclaimed Water specifications and requirements.

SIZE	MANUFACTURER	MODEL #
4-inch-12	Harrington Corporation (HARCO)	N/A
4-inch-12	Ipex	N/A
4-inch-12	Multi-Fittings	N/A

VALVES, HYDRANTS

AW-301: VALVE BOX AND COVER



DESCRIPTION: Valve Box and Cover. See Section 351 of the current JEA Standards for specifications and requirements. See Section 702 for Reclaimed Water specifications and requirements.

SIZE	MANUFACTURER	MODEL #
N/A	Tyler Pipe	461-S, Heavy Duty
N/A	Sigma Corp. (Russell Pipe)	VB-26, Heavy Duty
N/A	U.S. Foundry	7500, Heavy Duty
N/A	East Jordan Iron Works	461S, Heavy Duty
N/A	Star Pipe Products	VB 461 SHD, Heavy Duty
N/A	SIP	6004/6004CL35, Heavy Duty

AW-302: GATE VALVE



Note: All valves shall open by turning to the left. Mechanical joint shown as example only. See specifications for additional joints.

DESCRIPTION: Resilient Seat Gate Valve. See Chapter III. 2. - Section 351 of the current JEA Standards for specifications and requirements. See Chapter V. 2. - Section 702 for Reclaimed Water specifications and requirements.

Size	Manufacturer	M.Jt. Model #
3-inch to 12-inch	United Water Products	2010
3-inch & larger	American Flow Control (American Cast Iron Co)	2500 Series
3-inch & larger	AVK (S/S Stem Only)	Series 45
3-inch & larger	Clow Valve	F-6100
3-inch & larger	Kennedy Valve Company	8571
3-inch & larger	Mueller	A2360, A2361
3-inch & larger	M & H Valve Company	4067
3-inch & larger	U.S. Pipe	250
3-inch & larger	Mueller Co	A-2361 Series
3-inch & larger	American – RD (Product line of Kennedy Valve)	D100

AW-303: CONTROL VALVE



DESCRIPTION: Pressure control valves. Specification required by design engineer.

Size	Manufacturer	Model #
4-inch & larger	Bermad	730
4-inch & larger	Singer Valve	106RPS
4-inch & larger	Flomatic	COOO/CAOO

AW-304: TAPPING VALVE

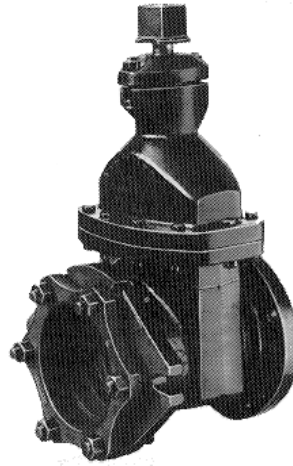

DESCRIPTION: See Chapter III. 2. - Section 351 of the current JEA Standards for specifications and requirements.
See Chapter V. 2. - Section 702 for Reclaimed Water specifications and requirements.

SIZE	MANUFACTURER	MODEL #
3-inch & larger	American Flow Control (American cast iron company)	N/A
3-inch & larger	AVK (S/S Stem Only)	25/30081
3-inch & larger	Clow Valve	F-6114, 2638
3-inch & larger	Kennedy Valve Company	950-X
3-inch & larger	M & H Valve	4751
3-inch & larger	Mueller	T-2360, T-2361
3-inch & larger	U.S. Pipe	5860
3-inch & larger	Mueller-Aqua Grip	A-2361-76
3-inch & larger	American – RD (Product line of Kennedy valve)	N/A

AW-305: CORPORATION STOP

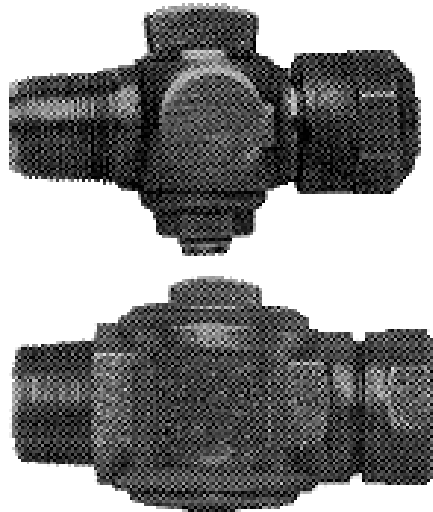

Note: Only full port valves are allowed.

DESCRIPTION: Corporation Stop Chapter III. 2. - Section 351 of the current JEA Standards for specifications and requirements. See Chapter V. 2. - Section 702 for Reclaimed Water specifications and requirements.

SIZE	MANUFACTURER	MODEL #
2-inch & smaller	Ford Meter Box Company	1000 Series
2-inch & smaller	A.Y. McDonald Mfg.	4700 Series
2-inch & smaller	Mueller	H Series
2-inch & smaller	Mueller	B Series
2-inch & smaller	James Jones Company	N/A
2-inch & smaller	Cambridge Brass	N/A

AW-306: INSERTION VALVE



DESCRIPTION: See Chapter IV.4. - Section 430 of the current JEA Standards for specifications and requirements.

SIZE	MANUFACTURER	MODEL #
4-inch thru 8-inch	ROMAC	310 Sleeve w/ 361 valve
10" thru 12"	ROMAC	311 Sleeve w/ 358 valve
14-inch & larger	Submittal and JEA Approval	Special Case

AW-307: CURB STOP

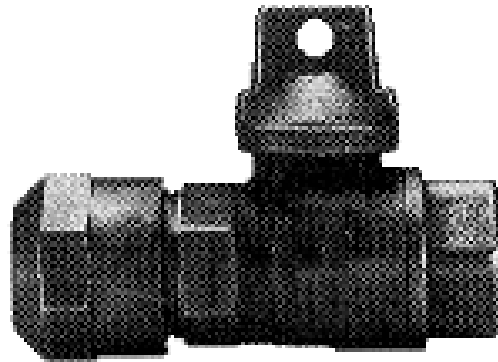

DESCRIPTION: Curb Stop, Ball Valve. See Chapter III.2. - Section 351 of the current JEA Standards for specifications and requirements. See Chapter V.2. - Section 702 for Reclaimed Water specifications and requirements. Only full port valves are allowed.

SIZE	MANUFACTURER	MODEL #
2-inch & smaller	Ford Meter Box Company	B11 Series (w/lockwing, FIPxFIP)
2-inch & smaller	Ford Meter Box Company	B41 Series (w/lockwing)
2-inch & smaller	McDonald A.Y. McDonald Mfg	6100 Series (w/lockwing)
2-inch & smaller	Mueller	B20200 (w/lockwing, FIPxFIP)
2-inch & smaller	Mueller	B25170 (w/lockwing)
2-inch & smaller	James Jones	N/A
2-inch & smaller	Cambridge Brass	N/A

AW-308: FIRE HYDRANT

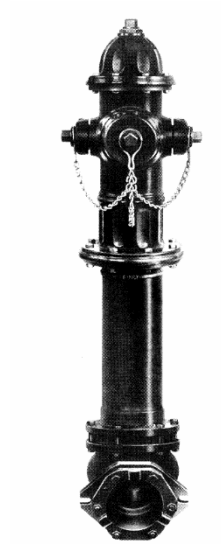

DESCRIPTION: 5¼" Fire Hydrant. See Chapter III.2. - Section 351 of the current JEA Standards for specifications and requirements.

MANUFACTURER	MODEL #
American Flow Control (American Cast Iron Company)	B-84-B
M & H Valve Company	129
Mueller Co	A-423
US Pipe/Muller	Met M94
AVK	2780

SERVICE PIPE ACCESSORIES

AW-401: BOLTLESS COUPLING

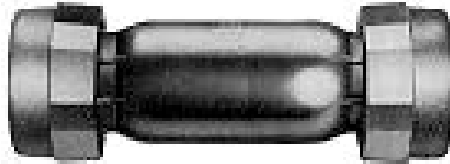

DESCRIPTION: Boltless Coupling (Long or Short type). See Chapter III. 1. - Section 350 of the current JEA Standards for specifications and requirements. See Chapter V.1. - Section 701 for Reclaimed Water specifications and requirements.

Size	Manufacturer	Model #
2-inch & smaller	Dresser Inc./GE	Style 65
2-inch & smaller	Smith-Blair	525
2-inch & smaller	TPS	Series 6000

AW-402: BRASS ADAPTER & COUPLER

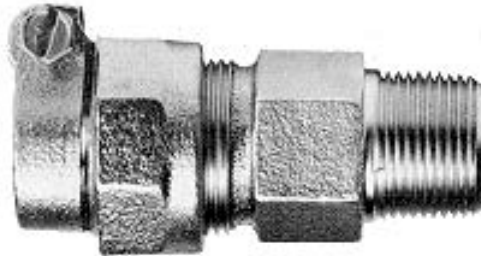

DESCRIPTION: Brass Adapters & Couplers. See Chapter III.1. - Section 350 of the current JEA Standards for specifications and requirements. See Chapter V.1. - Section 701 for Reclaimed Water specifications and requirements.

Size	Manufacturer	Model #
2-inch & smaller	The Ford Meter Box Co, Inc	
2-inch & smaller	McDonald A.Y. McDonald Mfg	
2-inch & smaller	Mueller	
2-inch & smaller	James Jones	
2-inch & smaller	Cambridge Brass	

AW-403: SERVICE SADDLE, DOUBLE STRAP



Note: Select desired saddle O.D. range which specifically matches outside diameter of pipe. Saddles for C-900 shall be sized to the exact O.D. size for proper fit. A double strap saddle will be required for all wet taps and are acceptable for installation on dry water supply mains (all sizes).

DESCRIPTION: Service Saddle shall be epoxy or poly coated with double stainless steel straps. See Chapter III.2. - Section 351 of the current JEA Standards for specifications and requirements. See Chapter V.2. - Section 702 for Reclaimed Water specifications and requirements.

Outlet Size	Manufacturer	Model #
2-inch & smaller	Cascade Waterworks Mfg.	CDS2/CDS-LD
2-inch & smaller	Dresser Inc./GE	291DS
2-inch & smaller	The Ford Meter Box Co.	FC – 202, 202BS
2-inch & smaller	JCM Industries	406
2-inch & smaller	Smith Blair	317
2-inch & smaller	Mueller	DR 25
2-inch & smaller	Power Seal	3417, 3409

AW-404: SERVICE SADDLE, SINGLE STRAP



Note: Select desired saddle O.D. range which specifically matches outside diameter of pipe. Saddles for C-900 shall be sized to the exact O.D. size for proper fit. Single Strap Saddle is approved for new 1-inch water services only which are installed on dry water main, sized 4-inch through 10 inch.

DESCRIPTION: Service Saddle shall be epoxy or poly coated with single stainless steel straps. See Chapter III.2. - Section 351 of the current JEA Standards for specifications and requirements. See Chapter V.2. - Section 702 for Reclaimed Water specifications and requirements.

Outlet Size	Manufacturer	Model #
1-inch & smaller	Cascade Waterworks Mfg.	CDS2
1-inch & smaller	Dresser Inc./GE	291-SS
1-inch & smaller	Ford Meter Box Company	FC-101
1-inch & smaller	JCM Industries	405
1-inch & smaller	Smith Blair	315
1-inch & smaller	Mueller	DR1S
1-inch & smaller	Power Seal	3417, 3409

AW-405: PAIR ADAPTORS

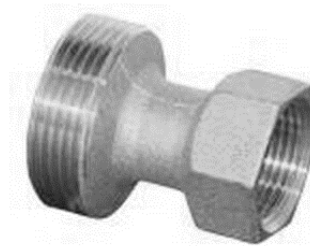

DESCRIPTION: Brass adaptor to change 3/4" meter to 5/8" meter spud size

SIZE	MANUFACTURER	MODEL #
3/4" to 5/8"	Ford	A13

AW-406: METER BOX



DESCRIPTION: Meter Box. See Chapter III.2. - Section 351 of the current JEA Standards for specifications and requirements. See Chapter V.2. - Section 702 for Reclaimed Water specifications and requirements.

Size	Box	Model #
N/A	Glassmasters	N/A
N/A	Southern Meter Box	N/A
N/A	Pentek	N/A

AW-407: METER



Size	Manufacturer	Contact
N/A	Badger Meter	Rebecca Loomans (414)426-7387

LARGE PIPE ACCESSORIES

AW-501: CAST COUPLING



DESCRIPTION: Cast Coupling. See Chapter III.1. - Section 350 of the current JEA Standards for specifications and requirements. See Chapter V.1. Section 701 for Reclaimed Water specifications and requirements.

Size	Manufacturer	Model #
4-inch & larger	Cascade Waterworks Mfg.	CDC, CRC, CRFA
4-inch & larger	Dresser Inc./GE	153, 262
4-inch & larger	Ford Meter Box	FC2A, FC2W
4-inch & larger	JCM Industries	210
4-inch & larger	PowerSeal	3501, 3501B, 3521
4-inch & larger	Romac	501
4-inch & larger	Smith-Blair	441
4-inch & larger	TPS, Hymax	2000
2-inch & larger	Mueller	MAXIFIT
4-inch & larger	Mueller Aqua Grip	

AW-502: FULL CIRCLE REPAIR CLAMP

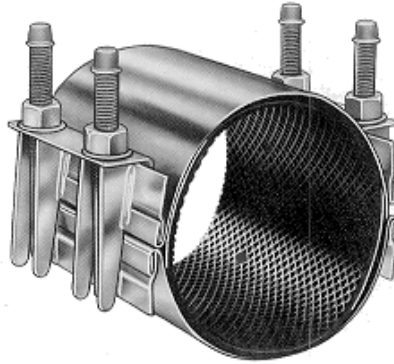

DESCRIPTION: Full Circle Repair Clamp (stainless steel). See Chapter III.1. - Section 350 of the current JEA Standards for specifications and requirements. See Chapter V.1. - Section 701 for Reclaimed Water specifications and requirements.

Size	Manufacturer	Model #
All Sizes	Cascade Waterworks Mfg.	CDR1, CDR2, CDR3
All Sizes	Dresser Inc./GE	360
All Sizes	The Ford Meter Box Co, Inc	"F", "FS" Series
All Sizes	JCM Industries	101, 131
All Sizes	JCM Industries	102, 132
All Sizes	Powerseal	3121, 3122
All Sizes	Romac	"SS", "CL" Series
All Sizes	Smith Blair	Series 226, 256
All Sizes	Smith Blair	Series 228, 263
All Sizes	TPS, EZ-MAX	Model 4000
All Sizes	Mueller	500, 510, 540, 550

AW-503: ACCESSORY PACK



DESCRIPTION: Accessory Pack: See Chapter III.1. - Section 350 of the current JEA Standards for specifications and requirements. See Chapter V.1. - Section 701 for Reclaimed Water specifications and requirements.

Size	Manufacturer	Model #
3-inch & larger	American Cast Iron Pipe Company	N/A
3-inch & larger	Clow Valve	N/A
3-inch & larger	Tyler Union	N/A
3-inch & larger	Sigma	N/A
3-inch & larger	U.S. Pipe	N/A
3-inch & larger	Star Pipe Products	N/A
3-inch & larger	SIP	N/A

AW-504: RESTRAINTS FOR PVC & D.I. PIPE



DESCRIPTION: Restraints for PVC or D.I. Pipe. See Chapter III.1. - Section 350 of the current JEA Standards for specifications and requirements. See Chapter V.1. - Section 701 for Reclaimed Water specifications and requirements.

Size	Manufacturer	Model #
All Sizes	EBAA Iron	1100 (Ductile Pipe Only)
All Sizes	EBAA Iron	2000 PV, 2000 SV (PVC Pipe Only)
All Sizes	The Ford Meter Box Co, Inc (Uniflange)	1400 (Ductile Pipe Only)
All Sizes	The Ford Meter Box Co, Inc (Uniflange)	1500 (PVC Pipe Only)
All Sizes	Sigma (Russell Pipe)	One-Lok SLCE (PVC Pipe Only)
All Sizes	Sigma (Russell Pipe)	One-Lok SLDE (Ductile Pipe Only)
All Sizes	Star Pipe Products	Stargrip 3000 (Ductile Pipe Only)
All Sizes	Star Pipe Products	AllGrip (Ductile/PVC Pipe)
All Sizes	Star Pipe Products	Stargrip 4000 (PVC Pipe)
All Sizes	Tyler Union	TUFGrip (Ductile-TLD/PVC-TLP Pipe)
All Sizes	SIP	EZPVC/EZVCU(PVC) EZD (DIP)

AW-505: PVC & D.I. BELL RESTRAINING DEVICE

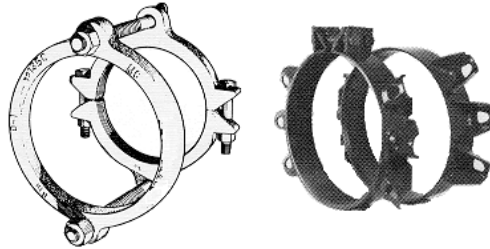

DESCRIPTION: Bell Restraining Devices. See Chapter III.1. - Section 350 of the current JEA Standards for specifications and requirements. See Chapter V.1. - Section 701 for Reclaimed Water specifications and requirements.

Size	Manufacturer	Model #
All Sizes	EBAA Iron	1500, 1600 Series (PVC/Ductile)
All Sizes	EBAA Iron	2500 Series (PVC Only)
All Sizes	EBAA Iron	2800 Series (PVC Only)
All Sizes	The Ford Meter Box Co, Inc (Uniflange)	1300 Series (PVC/Ductile)
All Sizes	The Ford Meter Box Co, Inc (Uniflange)	1350, 1360 Series (PVC Only)
All Sizes	The Ford Meter Box Co, Inc (Uniflange)	1390 Series (PVC/Ductile)
All Sizes	JCM	610 Series (PVC/Ductile)
All Sizes	JCM	621 Series (PVC/Ductile)
All Sizes	Romac	Grip Ring (PVC/Ductile)
All Sizes	Star Pipe Products, Inc.	1000, 1100 (PVC/Ductile), 1200 (PVC Only) Series
All Sizes	Star Pipe Products, Inc.	ALLGRIP 3600 (PVC/Ductile),
All Sizes	Star Pipe Products, Inc.	Stargrip 3100(Ductile only), 4100 (PVC Only)
All Sizes	Sigma (Russell Pipe)	PWP(PVC/Ductile)
All Sizes	Tyler Union	3000 (PVC Only)
All Sizes	SIP	PTPVC (PVC Only)

AW-506: MECHANICAL JOINT FASTENERS



DESCRIPTION: Mechanical Joint Fasteners. See Chapter III.1. - Section 350 of the current JEA Standards for specifications and requirements. See Chapter V.1. - Section 701 for Reclaimed Water specifications and requirements.

Size	Manufacturer	Model #
	Tie Lugs:	
	See Specifications	
	All Thread Rods:	
	See Specifications	
	Eye Bolts:	
	See Specifications	
	Nuts & Washers:	
	See Specifications	

AW-507: FLANGE ADAPTER



Note: The use of flange adapters shall be limited to areas specifically approved by JEA on a project-by-project basis.

DESCRIPTION: Flange Adapters. See Section 350 of the current JEA Standards for specifications and requirements. See Section 701 for Reclaimed Water specifications and requirements.

Size	Manufacturer	Model #
3-inch & larger	EBAA	Series 1000 DIP
3-inch & larger	EBAA	Series 2100 DIP
3-inch & larger	The Ford Meter Box Co, Inc (Uniflange)	200 C & S
3-inch & larger	The Ford Meter Box Co, Inc (Uniflange)	400 C& S
3-inch & larger	The Ford Meter Box Co, Inc (Uniflange)	900 C & S
3-inch & larger	The Ford Meter Box Co, Inc (Uniflange)	UFA-200 DIP
3-inch & larger	The Ford Meter Box Co, Inc (Uniflange)	UFA-900 PVC
3-inch & larger	Star Pipe	Series 200G
3-inch & larger	Star Pipe	Series 400G

AW-508: CASING SPACER

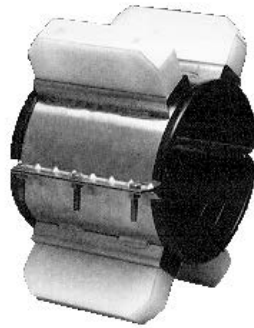

DESCRIPTION: Casing Spacers. See Chapter III.1. - Section 350 of the current JEA Standards for specifications and requirements. See Chapter VI.1. - Section 701 for Reclaimed Water specifications and requirements.

Size	Manufacturer	Model #
Varies	Cascade Waterworks Mfg.	CCS
Varies	EnPro Industries, Inc.	S/S Type
Varies	EnPro Industries, Inc.	PVC Coated Steel
Varies	RACI	High Density Polyethylene
Varies	Advanced Products & Systems, Inc.	SSI, SI, CI
Varies	BWM Company	
Varies	CCI Pipeline Systems	CSC, CSS

LOCATE WIRE

AW-601: LOCATE WIRE

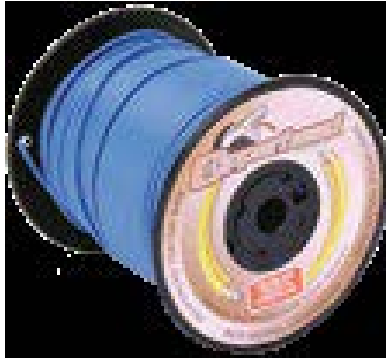

DESCRIPTION: Locate wiring for direct bury. See Chapter II.6. - Section 350 of the current JEA Standards for specifications and requirements

SIZE	MANUFACTURER	MODEL #
12-gauge	Copper Head Industries	Soloshot – 1230BHS500
12-gauge	Pro-Line Safety Products Co.	Protrace-744120232

AW-602: DIRECT BURY LUG



DESCRIPTION: Direct bury lug is for use with tracer lines.

SIZE	MANUFACTURER	MODEL #
	DRYCONN	90120-DB Lug Yellow

AW-603: LOCATE WIRE TESTING EQUIPMENT



DESCRIPTION: Cable/Fault Locator – Precisely locates sheath or ground faults on both long and short cable sections.

MANUFACTURER	MODEL #
3M Dynatel	2273
Metrotech	9800XT
Ditch Witch	950 R/T

MISC MATERIALS**AW-701: ADMIXTURES**

SIZE	MANUFACTURER	MODEL #
N/A	Hercules Power Company of Wilmington, Delaware	
N/A	Dewey and Almy Chemical Company, Cambridge Mass	
N/A	Master Builders Company, Cleveland Ohio	
N/A	L. Sonneborn Sons, Inc. 80 Eighth Avenue, New York, NY 10011	

AW-702: METALWORK FINISHES



Manufacturer	Contact	Model #
Alumilite		

WASTEWATER APPROVED MATERIALS

PIPE

AS-101: HDPE PIPE



DESCRIPTION: AWWA C906 Polyethylene (PE) Pressure Pipe and Fittings, 4-inch through 63-inch, for Water Distribution American Society for Testing and Materials (ASTM) Standards.

SIZE	MANUFACTURER	MODEL #
4-inch and larger		N/A

AS-102: PVC PRESSURE (DR18) PIPE



DESCRIPTION: DR18 PVC Pipe. See Chapter IV.2. - Section 428 & Chapter IV.3. - Section 429 of the current JEA Standards for specifications and requirements.

SIZE	MANUFACTURER	MODEL #
4-inch – 60	Diamond Plastics	N/A
4-inch – 48	JM Eagle	N/A
4-inch – 48	National Pipe & Plastics	N/A
4-inch – 36	North American Pipe Co. (NAPCO)	N/A
4-inch – 48	Ipex	N/A
4-inch – 12	Sanderson Pipe Corporation	N/A

DESCRIPTION: DR16 Pipe. See Chapter III. 1. - Section 350 of the current JEA Standards for specifications and requirements. See Chapter VI. 1. - Section 701 for Reclaimed Water specifications and requirements.

SIZE	MANUFACTURER	MODEL #
16-inch	Diamond Plastics	N/A
16-inch	JM Eagle	N/A
16-inch	National Pipe & Plastics/National PVC)	N/A
16-inch	North American Pipe Co. (NAPCO)	N/A
16-inch	Ipex	N/A

AS-103: PVC GRAVITY PIPE



DESCRIPTION: PVC SDR 26: See Chapter IV.2. - Section 428 of the current JEA Standards for specifications and requirements.

SIZE	MANUFACTURER	MODEL #
6-inch & larger	Charlotte Pipe	N/A
6-inch & larger	Diamond Plastics Corp	N/A
6-inch & larger	JM Eagle	N/A
6-inch & larger	National Pipe & Plastics	N/A
6-inch & larger	North American Pipe Co. (NAPCO)	N/A
6-inch & larger	Sanderson Pipe Co.	N/A
6-inch & larger	HAWK Plastics Corporation	SDR-26

AS-104: PVC PIPE (SCH 40 & SCH 80)



DESCRIPTION: PVC SCH 40 or 80 Pipe. See Chapter IV.3. - Section 429 of the current JEA Standards for specifications and requirements.

SIZE	MANUFACTURER	MODEL #
3-inch & smaller	JM Eagle	
3-inch & smaller	National Pipe & Plastics	
3-inch & smaller	North American Pipe Co. (NAPCO)	
3-inch & smaller	Sanderson Pipe Company	
3-inch & smaller	Accord Industries	
3-inch & smaller	Charlotte Pipe & Foundry	

AS-105: FIBERGLASS REINFORCED POLYMER MORTAR PIPE



SIZE	MANUFACTURER	MODEL #
18"-48"	HOBAS Pipe USA, Inc	

FITTINGS

AS-201: DUCTILE IRON FITTINGS



Note: Mechanical joint, 90-degree bend & fittings, shown as example only (for additional joints, see specifications).

DESCRIPTION: Ductile Iron Fitting, epoxy-lined. See Sections 428 & Chapter IV.3. - Section 429 of the current JEA Standards for specifications and requirements.

SIZE	MANUFACTURER	MODEL #
3-inch & larger	Tyler Union	N/A
3-inch & larger	Star Pipe Products	N/A
3-inch & larger	Sigma Corporation (Russell Pipe)	N/A
3-inch & larger	SIP Industries	N/A
3-inch & larger	US Pipe	N/A

AS-202: STAINLESS STEEL TAPPING SLEEVE

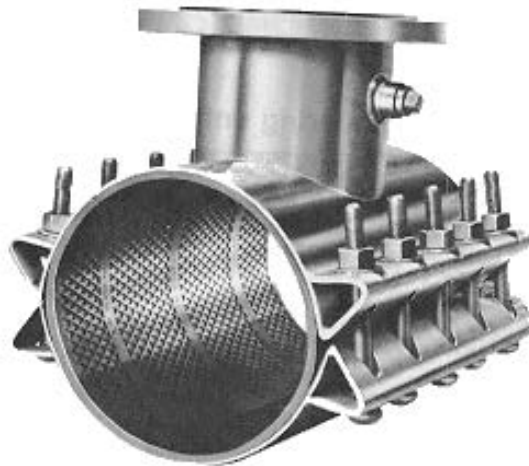

Note: Must be all stainless steel, no dissimilar metals allowed.

DESCRIPTION: Stainless Steel Tapping Sleeve. See Section 430 of the current JEA Standards for specifications and requirements.

SIZE	MANUFACTURER	MODEL #
4-inch & larger	Cascade Waterworks Mfg.	CST-EX
4-inch & larger	Dresser Inc./GE	630
4-inch & larger	Ford Meter Box Company	FAST Series, FTSS
4-inch & larger	JCM Industries, Inc.	432, 439, 452, (taps 14-inch and larger)
4-inch & larger	Power Seal	3490, 3490MJ (8-inch and smaller)
4-inch & larger	Romac Industries, Inc.	SST
4-inch & larger	Smith-Blair	N/A
4-inch & larger	Mueller	H304

AS-203: PVC SOLVENT WELD FITTING



DESCRIPTION: Schedule 40 and 80 Solvent Weld Fittings. See Chapter IV.3. - Section 429 of the current JEA Standards for specifications and requirements.

SIZE	MANUFACTURER	MODEL #
3-inch & smaller	Ipex	
3-inch & smaller	LASCO Fittings, Inc.	
3-inch & smaller	Nibco	
3-inch & smaller	Georg Fischer Sloane (GF Piping Systems)	
3-inch & smaller	Spears	
3-inch & smaller	Charlotte Pipe & Foundry	

AS-204: PVC GRAVITY FITTING (SDR26)



DESCRIPTION: PVC Gravity Fitting (SDR26). See Chapter IV.2. - Section 428 of the current JEA Standards for specifications and requirements.

SIZE	MANUFACTURER	MODEL #
6-inch & larger	GPK Products, Inc	
6-inch & larger	Harco Inc.	
6-inch & larger	Multi Fittings	
6-inch & larger	Tigre-ADS USA	
6-inch & larger	Plastic Trends (Royal Building Projects)	

AS-205: PVC PRESSURE FITTING



DESCRIPTION: For 12-inch and smaller (Pressure Fittings) - PVC C900, DR18 Injection Molded, Push-On Joint Fittings. See Chapter IV.3. - Section 429 of the current JEA Standards for specifications and requirements. For 14-inch and larger (pressure Fittings) - PVC C905 Fabricated Fittings (no Tee Fitting). See Chapter IV.3. - Section 429 of the current JEA Standards for specifications and requirements.

SIZE	MANUFACTURER	MODEL #
4-inch – 12-inch	Harco Inc.	N/A
4-inch – 12-inch	Multi-Fittings	N/A
4-inch & larger	IPEX	N/A
14-inch & larger	Galaxy Plastics	N/A
14-inch & larger	Plastic Trends (Royal Building Projects)	N/A

VALVES

AS-301: VALVE BOX AND COVER



DESCRIPTION: Valve Box and Cover. See Section 430 of the current JEA Standards for specifications and requirements.

SIZE	MANUFACTURER	MODEL #
N/A	Tyler Union	461-S, Heavy Duty
N/A	Sigma (Russell Pipe)	VB-26, Heavy Duty
N/A	U.S. Foundry	7500, Heavy Duty
N/A	East Jordon Iron Works	461S, Heavy Duty
N/A	Star Pipe Products	VB 461 SHD, Heavy Duty
N/A	SIP	6004/6004CL35, Heavy Duty

AS-302: GATE VALVE



Note: All valves shall open by turning to the left. Mechanical joint shown as example only. See specifications for additional joints.

DESCRIPTION: Resilient Seat Gate Valve. See Section 430 of the current JEA Standards for specifications and requirements.

SIZE	MANUFACTURER	M.Jt. MODEL #
3-inch & larger	AVK (S/S Stem Only)	Series 45
3-inch & larger	American Flow Control (American Cast Iron Pipe Company)	2500 Series
3-inch & larger	Clow Valve	F-6100
3-inch & larger	Kennedy Valve Company	8571
3-inch & larger	M & H Valve Company	4067
3-inch & larger	Mueller	A2360, 2361
3-inch & larger	U.S. Pipe	250
3-inch & larger	American – RD (Kennedy Valve)	D 100
3-inch to 12-inch	United Water Products	2010

AS-303: TAPPING VALVE

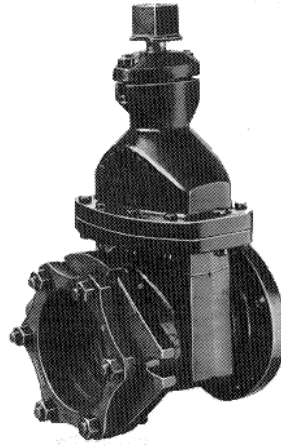

Note: All valves shall open by turning to the left.

DESCRIPTION: Tapping Valve. See Section 430 of the current JEA Standards for specifications and requirements.

SIZE	MANUFACTURER	MODEL #
3-inch & larger	American Flow Control (American Cast Iron Pipe Company)	N/A
3-inch & larger	AVK (S/S Stem Only)	25/30081
3-inch & larger	Clow Valve	F-6114
3-inch & larger	Kennedy Valve Company	8950
3-inch & larger	M & H Valve	4751
3-inch & larger	Mueller	T-2360, 2361
3-inch & larger	U.S. Pipe	5860
3-inch & larger	Mueller – Aqua Grip	A-2361-76
3-inch & larger	American – RD (Kennedy Valve)	N/A

DESCRIPTION: Insert-A-Valve: See Section 430 of the JEA Standards for specifications and requirements.

SIZE	MANUFACTURER	MODEL #
4" thru 8"	ROMAC	310 Sleeve w/361 valve
10" thru 12"	ROMAC	311 Sleeve w/358 valve
4" thru 12"	Hydrastop	Insta-Valve
14"	Submittal and JEA Approval	Special Case

AS-304: PLUG VALVE

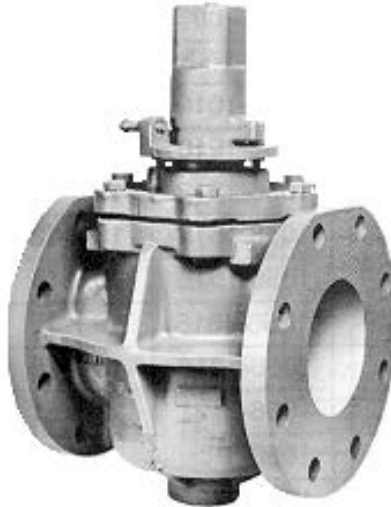

Note: Flange joint shown as example only. (For additional joints, see specifications.)

DESCRIPTION: Plug Valve. See Section 430 of the current JEA Standards for specifications and requirements. Actuator may be required to achieve 150 P.S.I. drip tight shut-off in both directions. Contact valve manufacturer for requirements.

SIZE	MANUFACTURER	MODEL #
3-inch & larger	Clow Valve /Kennedy	N/A
3-inch & larger	Dezurik	N/A
3-inch & larger	Dezurik	N/A
3-inch & larger	TYCO/Keystone	Eccentric Valve
3-inch & larger	Milliken Valve or Mueller Water Products	600 N (MJ)
3-inch & larger	Milliken Valve/Mueller Water Products	601 N (FLG)
3-inch & larger	Henry Pratt Co	N/A
3-inch & larger	Val-Matic	N/A
3-inch & larger	Golden Anderson	N/A
3-inch & larger	Homestead	N/A

AS-305: CHECK VALVE

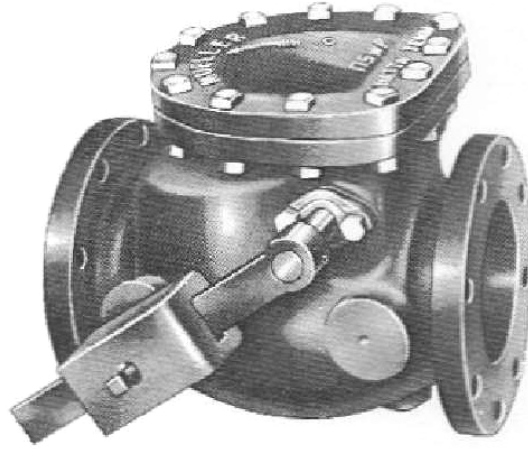

DESCRIPTION: Check Valve. See Section 430 of the current JEA Standards for specifications and requirements.

SIZE	MANUFACTURER	MODEL #
3-inch & larger	American Flow Control (American Cast Iron Pipe Company)	50SC-LW
3-inch & larger	Clow Valve/Kennedy	106LW
3-inch & larger	M & H Valve	159-02
3-inch & larger	Mueller/CNNE(Charles Finch)/Milliken	8001
3-inch & larger	NIBCO	F938-31-BL&W
3-inch & larger	Matco-Norca	
3-inch & larger	Golden Anderson	
3-inch & larger	United	

AS-306: AIR VALVE



DESCRIPTION: Air Valve. See Section 430 of the current JEA Standards for specifications and requirements. It should be noted that, per the specification, valves may require back wash feature, stainless steel body or other requirements.

SIZE	MANUFACTURER	MODEL #
Varies	Vent-O-Mat	Series RGX II
Varies	A.R.I. USA	D-025-ST/D-26 NS
Varies	H-TEC USA	Series 989/986

ARV Height (inches)					
ARV	2 (NPT)	3 (NPT)	3 (FLG)	4 (FLG)	6 (FLG)
ARI D-025-ST	17.9	17.9	18.1	18.1	-
ARI D-26 NS	21.8	24.4	24.4	34.5	39.4
VOM RGX II	16.0	-	25.6	25.6	31.45
H-TEC 989	18.9	-	-	-	-
H-TEC 986	24.4	24.4	24.7	24.7	24.7
Total Installed Height (inches)					
ARV	2 (NPT)	3 (NPT)	3 (FLG)	4 (FLG)	6 (FLG)
ARI D-025-ST	25.1	25.1	25.3	25.3	
ARI D-26 NS	29.0	36.6	42.2	53.3	64.7
VOM RGX II	23.2	-	43.4	44.4	56.7
H-TEC 989	26.1	-	-	-	-
H-TEC 986	31.6	36.6	42.5	43.5	50.0

AS-307: INSERTION VALVE



DESCRIPTION: See Chapter IV.4. - Section 430 of the current JEA Standards for specifications and requirements.

SIZE	MANUFACTURER	MODEL #
4" thru 8"	ROMAC	310 Sleeve w/ 361 valve
10" thru 12"	ROMAC	311 Sleeve w/ 358 valve
4"-12"	Hydra-Stop	Insta-Valve
14" & larger	Submittal and JEA Approval	Special Case

PIPE ACCESSORIES

AS-401: FULL CIRCLE 2" TAPPING SADDLE FOR ARVS



DESCRIPTION: Full Circle 2" Tapping Sleeve 316 Stainless Steel for ARVs. See Chapter V.3. - Section 430 and Chapter III - Section 351 of the current JEA Standards for specifications and requirements.

SIZE	MANUFACTURER	MODEL #
3" to 48"	Ford Meter Box, Co	FAST-Q or FTSS-Q series
4" to 24"	JCM Industries, Inc.	6433 Series

AS-402: RESTRAINTS FOR PVC OR D.I. PIPE



DESCRIPTION: Restraints for PVC or D.I. Pipe. See Section 429 of the current JEA Standards for specifications and requirements.

SIZE	MANUFACTURER	MODEL #
3-inch & larger	EBAA Iron	1100 (Ductile Pipe Only)
3-inch & larger	EBAA Iron	2000 PV, 2000 SV (PVC Pipe Only)
3-inch & larger	The Ford Meter Box Co, Inc (Uniflange)	1400 (Ductile Pipe Only)
3-inch & larger	The Ford Meter Box Co, Inc (Uniflange)	1500 (PVC Pipe Only)
3-inch to 10-inch	Sigma (Russell Pipe)	One-Lok SLCE – (PVC pipe only)
12-inch & larger	Sigma (Russell Pipe)	One-Lok SLCE – (PVC pipe only)
3-inch & larger	Sigma (Russell Pipe)	One-Lok SLDE – (Ductile Pipe Only)
3-inch & larger	Star Pipe	Stargrip 3000 (Ductile Pipe Only)
3-inch & larger	Star Pipe	Stargrip 4000 (PVC Pipe)
3-inch & larger	Tyler Union	TUFGrip (Ductile-TLD/PVC-TLP Pipe)
3-inch & larger	SIP	EZPVC/EZVCU (PVC) EZD (DIP)

AS-403: PVC OR D.I. BELL RESTRAINING DEVICE

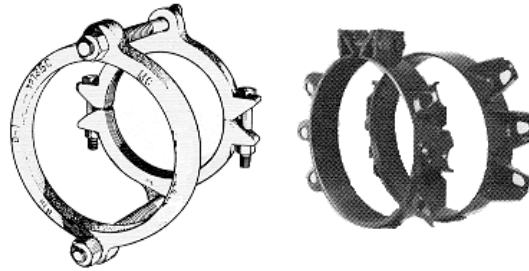

DESCRIPTION: Bell Restraining Devices. See Section 429 of the current JEA Standards for specifications and requirements.

SIZE	MANUFACTURER	MODEL #
3-inch & larger	EBAA Iron	1500 Series (PVC/Ductile)
3-inch & larger	EBAA Iron	1600 Series (PVC/Ductile)
3-inch & larger	EBAA Iron	2500 Series (PVC Only)
3-inch & larger	EBAA Iron	2800 Series (PVC Only)
3-inch & larger	The Ford Meter Box Co, Inc (Uniflange)	1300 Series (PVC/Ductile)
3-inch & larger	The Ford Meter Box Co, Inc (Uniflange)	1350 Series (PVC Only)
3-inch & larger	The Ford Meter Box Co, Inc (Uniflange)	1360 Series (PVC Only)
3-inch & larger	The Ford Meter Box Co, Inc (Uniflange)	1390 Series (PVC/Ductile)
3-inch & larger	JCM Industries	610 Series (PVC/Ductile)
3-inch & larger	JCM Industries	621 Series (PVC/Ductile)
3-inch & larger	Romac	Grip Ring (PVC/Ductile)
3-inch & larger	Star Pipe Products, Inc.	ALLGRIP 3600 (PVC/Ductile)
3-inch & larger	Star Pipe Products, Inc.	1000, 1100 (PVC/Ductile), 1200 (PVC Only) Series
3-inch & larger	Star Pipe Products, Inc.	Stargrip 3100 (Ductile Only), 4100 (PVC Only)
3-inch & larger	Tyler Union	3000 (PVC Only)
3-inch & larger	Sigma (Russell Pipe)	PWP(PVC/Ductile)
3-inch & larger	SIP	PTPVC (PVC Only)

AS-404: ACCESSORY PACK



DESCRIPTION: Accessory Pack. See Chapter IV.3. - Section 429 of the current JEA Standards for specifications and requirements.

SIZE	MANUFACTURER	MODEL #
3-inch & larger	American Cast Iron Pipe Company	N/A
3-inch & larger	Clow Valve	N/A
3-inch & larger	Tyler Union	N/A
3-inch & larger	U.S. Pipe and Foundry	N/A
3-inch & larger	Sigma	N/A
3-inch & larger	Star Pipe Products	N/A
3-inch & larger	SIP	N/A

AS-405: MECHANICAL JOINT FASTENER



DESCRIPTION: Mechanical Joint Fasteners. See Chapter IV.3. - Section 429 of the current JEA Standards for specifications and requirements.

SIZE	MANUFACTURER	MODEL #
	Tie Lugs	
	All Thread Rods	
	Eye Bolts	
	Nuts & Washers	

AS-406: FLANGE ADAPTER



DESCRIPTION: Flange Adapters. See Section 429 of the current JEA Standards for specifications and requirements. The use of flange adapters shall be limited to areas specifically approved by JEA on a project-by-project basis.

SIZE	MANUFACTURER	MODEL #
3-inch & larger	EBAA	Series 1000 DIP only
3-inch & larger	EBAA Iron	Series 2100 PVC or DI
3-inch & larger	The Ford Meter Box Co, Inc (Uniflange)	200 C & S 400 C & S 900 C & S
3-inch & larger	The Ford Meter Box Co, Inc (Uniflange)	UFA-200 DIP UFA-900 PVC
3-inch & larger	Star Pipe	Series 200G Series 400G

DESCRIPTION: Flanged Couple Adapters. See Section 429 of the current JEA Standards for specifications and requirements. A restrained ductile iron flanged coupling adapter (flanged X MJ) with special interior coating may be utilized to transition between different pipe materials (PVC to S/S).

SIZE	MANUFACTURER	MODEL #
	Romac PVC-RFCA	

AS-407: CASING SPACER

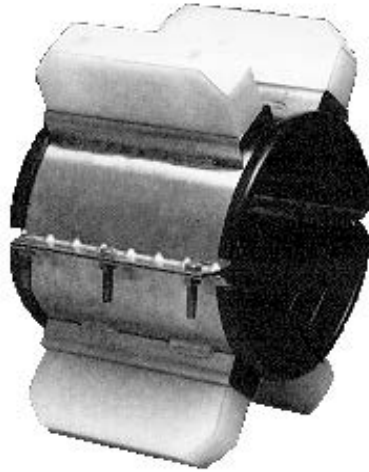

DESCRIPTION: Casing Spacers. See Sections 428 & Chapter IV.3. - Section 429 of the current JEA Standards for specifications and requirements.

SIZE	MANUFACTURER	MODEL #
Varies	Cascade Waterworks Mfg.	CCS
Varies	Pipeline Seal & Insulator, Co (EnPro Industries, Inc.)	S/S Type
Varies	Pipeline Seal & Insulator, Co (EnPro Industries, Inc.)	PVC Coated Steel
Varies	Pipeline Seal & Insulator, Co (EnPro Industries, Inc.)	Ranger II
Varies	Raci Spacers	High Density Polyethylene
Varies	BWM Company	N/A
Varies	Advanced Products & Systems	SSI, SI, CI
Varies	CCI Pipeline Systems	CSC, CSS

AS-408: PIPE COUPLING



DESCRIPTION: Cast Coupling. See Chapter IV.2. - Section 428 of the current JEA Standards for specifications and requirements, including coating requirements.

SIZE	MANUFACTURER	MODEL #
4-inch & larger	Cascade Waterworks Mfg.	CDC, CRC, CRFA
4-inch & larger	Dressler Inc./GE	153
4-inch & larger	Ford Meter Box	FC2A, FC2N
4-inch & larger	JCM	210
4-inch & larger	PowerSeal	3501, 3501B, 3506, 3521
4-inch & larger	Romac	501
4-inch & larger	Smith-Blair	441
4-inch & larger	TPS, Hymax	2000
4-inch & larger	Mueller	MAXIFIT
4-inch & larger	Mueller Co	N/A
4-inch & larger	FERNCO	1000

AS-409: FULL CIRCLE REPAIR CLAMP

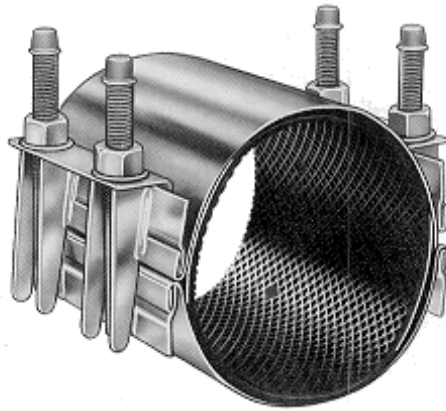

DESCRIPTION: Full Circle Repair Clamp (stainless steel). See Chapter IV. 3. - Section 429 of the current JEA Standards for specifications and requirements.

SIZE	MANUFACTURER	MODEL #
All Sizes	Ford Meter Box, Co	"F" or "FS" Series
All Sizes	Dresser Inc./GE	360
All Sizes	JCM Industries	101 or 131
All Sizes	JCM Industries	102 or 132
All Sizes	Powerseal	3121 or 3122
All Sizes	Romac	"SS" or "CL" Series
All Sizes	Smith Blair	Series 226 or 256
All Sizes	Smith Blair	Series 228 or 263
All Sizes	TPS, EZ-MAX	Model 4000
All Sizes	Mueller Co.	500, 510, 540, 550

MANHOLES

AS-501: MANHOLE AND ACCESSORIES

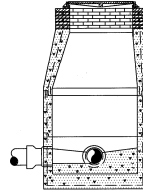

DESCRIPTION: Manhole and Accessories. See Section 427 of the current JEA Standards for specifications and requirements.

SIZE	MANUFACTURER	MODEL #
Precast Manhole		
Varies	Old Castle	N/A
Varies	Del Zotto Precast	N/A
Varies	FORTERRA	N/A
Varies	American Precast	N/A
Poly-Concrete		
Varies	Armorock	N/A
Manhole Joint Sealant		
1-inch	Con-Seal	CS102, 202
1-1/2 inch	Ram-Nek/Henry Company	Ram-Nek
	NPC Bidco /Trelleborg	C-56
1-inch	Evergrip	990
Exterior Joint Sealant Tape		
0.1 inch X 8 inch W (minimum)	Con Seal	CS-300, CS-212
9 inch W (minimum)	Rub-R-Nek/ Henry Company	N/A
18 inch W (minimum)	Wrapid Seal (CCI Pipeline systems)	N/A
Manhole General Coating		
12 mils thick	Con-Seal	CS-55
12 mils thick	PRO-Tec Coatings, Inc.	EW1-Aquapoxy
Fiberglass		
Varies	L. F. Manufacturing Inc	
Varies	Containment Solutions Inc (Flowlite) Fiberglass Manhole	N/A
Varies	Associated Fiberglass Enterprises	N/A

AS-502: PROTECTIVE COATING



DESCRIPTION: Water Wastewater Protective Coating. See Section 447 of the current JEA Standards for specifications and requirements.

COMPANY NAME	CONTACTS	PHONE	EMAIL
The Sherwin-Williams Company	Josh Hinson	904-591-3137	swrep4538@sherwin.com
Corrocoat Usa, Inc.	Josh Tankersley	904-472-0768	Josht@corrocoat.com
PPG Protective & Marine Coatings	Jim Hartley	904-626-6382	jim.hartley@ppg.com
Tnemec (Capital Only)			

AS-503: MANHOLE ADJUSTMENT RING



DESCRIPTION: Manhole (adjustment rings) Collars. See Section 427 of the current JEA Standards for specifications and requirements.

SIZE	MANUFACTURER	MODEL #
Varies	Old Castle	
Varies	Lad Tech, HDPE Rings	
Varies	EJ, Steel Adjustment Ring	
Varies	EJ, infra-riser	
Varies	Cretex Pro-Ring, EPP Adjustment Ring	

AS-504: MANHOLE FRAME AND COVER

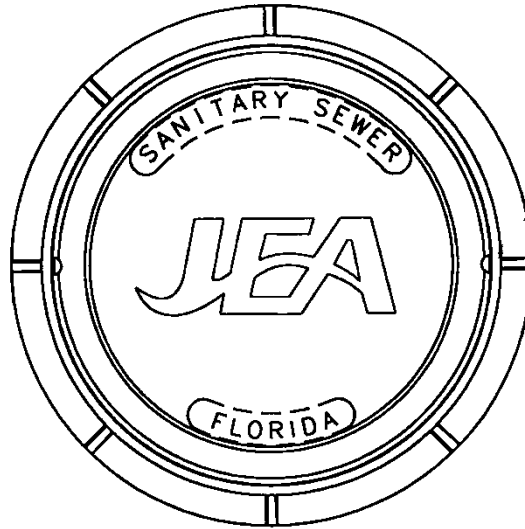

DESCRIPTION: Manhole Frame and Cover (with rubber "T" Gaskets). See Section 427 of the current JEA Standards for specifications and requirements.

SIZE	MANUFACTURER	MODEL #
32-inch	U.S. Foundry	USF-655
32-inch	East Jordan Iron Works	N/A

AS-505: MANHOLE MONITOR



DESCRIPTION: Aluminum Hatch Frame and Cover. See Section 433 of the current JEA Standard for specifications and requirements.

TYPE	MANUFACTURER	MODEL #
Continuous	ADS	
Discrete	Mission SCADA	

PUMP STATIONS

AS-601: ALUMINUM HATCH (FRAME AND COVER)

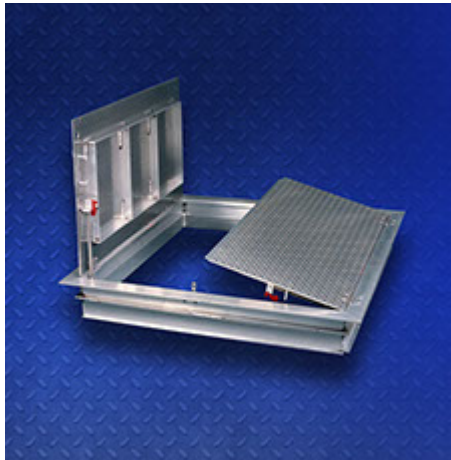

DESCRIPTION: Aluminum Hatch Frame and Cover. See Section 433 of the current JEA Standard for specifications and requirements.

SIZE	MANUFACTURER	MODEL #
Varies	U.S. Foundry	
Varies	Halliday Products, Inc.	

AS-602: CONCRETE LINER



DESCRIPTION: Concrete Liner. See Section 446 of the current JEA Standards for specifications and requirements.

MANUFACTURER	MODEL #
Associated Fiberglass Enterprises	Hard Shell Liner (*****)
Concrete Conservation, Inc.	Spectra-Shield (***)
L. F. Manufacturing, Inc.	Hard Shell Liner (*****)
LarFarge/ Kerneos Inc. Calcium Aluminates	SEWPERCOAT (**)
GML Coatings, LLC.	Green Monster (***)
Derakane	8084 Resin (*)
Armorock	Rehabilitation Insert (*****)
Sprayroq	Spraywall™ (****)

- NOTES:
- (*) Denotes Surface Primer
 - (**) Denotes Cementitious or Polymer Modified Cementitious Coating
 - (***) Denotes Epoxy, Polyurea or Polyurethane Corrosion Inhibiting Coating
 - (****) Denotes Epoxy, Polyurea or Polyurethane Structural Coating
 - (*****) Denotes Fiberglass or Polymer Concrete Liner Material

AS-603: WASTEWATER PUMP



DESCRIPTION: Wastewater Pump. See Section 433 of the current JEA Standards for specifications and requirements.

MANUFACTURER	POINT OF CONTACT	CONTACT NUMBER
SUBMERSIBLE WASTEWATER 1800 RPM PUMPS		
Flygt	David Williams	(239) 825-8384
WILO-EMU,	PSI Technologies	(904) 588-2132
KSB	Custom Pump	(904) 858-9605
Hydromatic	Barneys Pump (40hp and less)	(904) 260-0669
Shinmaywa	David Lee	(904) 228-7602
SUBMERSIBLE WASTEWATER 3600 RPM PUMPS		
Flygt	David Williams	(239) 825-8384
KSB	Custom Pump	(904) 858-9605
DRY-PIT WASTEWATER PUMPS		
WILO-EMU	PSI Technologies	(904) 588-2132
Flow Serve (MSX	Carter & Ver Planck	(813) 287-0709
KSB	Custom Pump	(904) 858-9605
Flygt	David Williams	(239) 825 8384
FLOODED SUCTION SOLIDS HANDLING PUMPS		
Fairbanks Morse	Sanders Company, Inc.	(772)-220-2900
Worthington	Carter & Ver Planck	(813) 287-0709
Allis Chalmers	David Williams	(239) 825-8384
LOW PRESSURE SYSTEM (LPS)		
Myers MW50	Custom Pump & Controls Scott Strong	(904) 858-9605

AS-604: ELECTRICAL, CONTROL PANEL, VFD & SCADA



DESCRIPTION: Pump Station Electrical and Control Panel including (RTU) and Variable Frequency Drives (VFD).
See Section 433 of the current JEA Standards for specifications and requirements.

COMPANY NAME	CONTACT	PHONE	EMAIL
ECS*	Ralph Sinn	(904)367-5000	ralph@ecs31.com
EG Controls, Inc.*	Sonia Kenzie	(904)292-0110	smcenizie@egcontrols.com
Suncoast*	Mark Owens	(904)693-3318	mowens@suncoastcontrols.biz
Sun State System, Inc.*	Tony Rhodes	(904)269-2544	trhodes@sunstatesystems.com
Information Technologies Group (ITG) * **	James Ruiz	(904)425-4760	jruiz@itgtec.com
DSI Innovations LLC*. **	Sean Patterson	(336)893.8385	spatterson@dsiinnovations.com
Tesco Controls ** (provisional)	Kyle Hady	916-395-8800	khady@tescocontrols.com

NOTES:

*Approved electrical control panel manufacturers

** Approved SCADA integrators

VFD	SCADA
Siemens G120X	Siemens
Danfoss Aqua Drive	
ABB ACQ580	
Schneider Altivar Process ATV630	
Toshiba VF-AS3	

AS-605: EMERGENCY PUMP ENGINE



DESCRIPTION: Emergency Pump Engines: See Section 470 of the current JEA Standards for specifications and requirements.

PUMP MANUFACTURER	CONTACTS	PHONE	EMAIL
Thompson Pump	Brian Lee	(386) 212-6999	blee@thompsonpump.com
Holland Pump	Eugene Lant	(321) 297-6372	eugene@hollandpump.com
Godwin Pump	Lee Hilbert	(904) 349-5503	lee.hilbert@xyleminc.com

ENGINE MANUFACTURER	4" PUMP/SET	6" PUMP/SET	8" PUMP/SET	10" PUMP/SET	12" PUMP/SET
John Deere	N/A	4045T280-SP2	4045T285-SP2	6068H285-SP2	6090H485-SP1
Caterpillar (C18 Tier3)*	2.2T-SP	C4.4T-SP	C4.4E-TA-SP	C6.65E-SP	C9-SP
Mitsubishi	S4Q2-VS/14A	N/A	N/A	N/A	N/A
Cummins	QSF2.8 (49)	QSF2.8 (65)	QSB4.5	QSB4.5 OR QSB6.7	QSB6.7 OR QSB9
Izuzu	4LE2T	4LE2X	N/A	N/A	N/A
Yanmar	3TNV88F- EPMT	N/A	N/A	N/A	N/A

*Optional for greater than 12" pump/set

VACUUM SYSTEM

AS-701: VACUUM SEWER VALVE



DESCRIPTION: Vacuum sewer pod valve and controller.

VACUUM MANUFACTURER	CONTACTS	PHONE	EMAIL
Flovac	Michael Pringle	(386) 319-0350	MPringle@flovac.com
Airvac	Becky Murphy; Aqseptence Group, Inc.	(574) 208-5904	

LOCATE WIRE

AS-801: LOCATE WIRE



Description: Locate wiring for direct bury.

SIZE	MANUFACTURER	MODEL #
12-Gauge	Copper Head Industries	Soloshot-1230GHS500
12-Gauge	Pro Line Safety Products Co.	Pro-Trace 744120532

AS-802: DIRECT BURY LUG



DESCRIPTION: Direct bury lug is for use with tracer lines, solid copper or steel copper. Lug is made of high conductivity aluminum and plated with tin.

SIZE	MANUFACTURER	MODEL #
	DRYCONN	90120-DB Lug Yellow – 5 pc bag

AS-803: LOCATE WIRE TESTING EQUIPMENT



DESCRIPTION: Cable/Fault Locator – Precisely locates sheath or ground faults on both long and short cable sections.

SIZE	MANUFACTURER	MODEL #
	3M Dynatel	2273
	Metrotech	9800XT
	Ditch Witch	950 r/t

MISC MATERIALS**AS-901: ADMIXTURES**

SIZE	MANUFACTURER	MODEL #
	Hercules Power Company of Wilmington, Delaware	
	Dewey and Almy Chemical Company, Cambridge Mass	
	Master Builders Company, Cleveland Ohio	
	L. Sonneborn Sons, Inc. 80 Eighth Avenue, New York, NY 10011	

AS-902: METALWORK FINISH



MANUFACTURER	CONTACTS	PHONE	EMAIL
Alumilite			

WASTEWATER TREATMENT PLANT APPROVED MATERIALS

PROTECTIVE COATING

WWT-101: PROTECTIVE COATING



DESCRIPTION: Water Wastewater Protective Coating. See Section 447 of the current JEA Standards for specifications and requirements.

COMPANY NAME	CONTACTS	PHONE	EMAIL
The Sherwin-Williams Company	Josh Hinson	904-591-3137	swrep4538@sherwin.com
Corrocoat Usa, Inc.	Josh Tankersley	904-472-0768	Josht@corrocoat.com
Carboline			
PPG Protective & Marine Coatings	Jim Hartley	904-626-6382	jim.hartley@ppg.com

ELECTRICAL, CONTROL PANEL, VFD & SCADA

WWT-201: ELECTRICAL CONTROL PANEL



DESCRIPTION:

COMPANY NAME	CONTACT	PHONE	EMAIL
ECS	Ralph Sinn	(904)367-5000	ralph@ecs31.com
EG Controls, Inc.	Sonia Kenzie	(904)292-0110	smcenizie@egcontrols.com
Suncoast	Mark Owens	(904)693-3318	mowens@suncoastcontrols.biz
Sun State System, Inc.	Tony Rhodes	(904)269-2544	trhodes@sunstatesystems.com
DSI Innovations LLC.	Sean Patterson	(336)893.8385	spatterson@dsiinnovations.com
Information Technologies Group (ITG)	James Ruiz	(904)425-4760	jruiz@itgtec.com

WWT-202: SCADA SYSTEM INTEGRATION



DESCRIPTION:

COMPANY NAME	CONTACT	PHONE	EMAIL
Information Technologies Group (ITG)	James Ruiz	(904)425-4760	jruiz@itgtec.com
DSI Innovations LLC.	Sean Patterson	(336)893.8385	spatterson@dsiinnovations.com
Tesco Controls (provisional)	Kyle Hady	916-395-8800	khady@tescocontrols.com

SCADA SYSTEM	CONTACT	PHONE	EMAIL
Siemens			

WWT-203: VARIABLE FREQUENCY DRIVES



DESCRIPTION:

COMPANY NAME AND MODEL		CONTACT	PHONE	EMAIL
ABB	ACQ580	Sean Connaway	(904)325-4940	Sean.connaway@us.abb.com
Danfoss	Aqua Drive	David Lee	(904)228-7602	dlee@powerandpumps.com
Siemens	G120X	Samuel Hope	(904)610-1097	Samuel.hope@awc-inc.com
Schneider	Altivar Process ATV630	John Tice	(321)695-8198	John.tice@graybar.com
Toshiba	VF-AS3	David Lee	(904)228-7602	dlee@powerandpumps.com

SCREENS

WWT-301: WWTP SCREENS



DESCRIPTION: Mechanisms to retain debris contained in flow streams in order to protect equipment or processes located downstream.

SIZE	MANUFACTURER	MODEL #
	Waste Tech/Kusters Water	N/A
	John Meunier	N/A
	JWC	N/A
	Vulcan	N/A
	Huber	N/A
	Hydro Dyne Engineering	N/A
	WSG Solutions	N/A

UV SYSTEMS

WWT-401: UV DISINFECTION EQUIPMENT



DESCRIPTION: Technology capable of providing effective WWTP effluent disinfection while reducing safety and environmental toxicity issues.

SIZE	MANUFACTURER	MODEL #
	Trojan Technologies Inc.	N/A
	UV300+	N/A
	Tak-55HP	N/A
	Ozonix-Degremont Technologies/Aquaray 40 and 40HO	N/A
	Severn Trent MicroDynamics	N/A
	Wedco	N/A

ODOR CONTROL

WWT-402: ODOR CONTROL



DESCRIPTION: Equipment designed to remove odor-causing compounds eliminating nuisance odors.

SIZE	MANUFACTURER	MODEL #
	Evoqua Water Technologies	N/A
	Heyward Florida Incorporated	N/A
	KCH Services, Inc.	N/A
	Bio Air Solutions	N/A

GATES

WWT-501: SLUICE/SLIDE GATES



DESCRIPTION: Sluice/Slide gates are used to control the flow of fluid through openings under seating or unseating head.

SIZE	MANUFACTURER	MODEL #
	Ashbrook Simon-Hartley Coplastix	N/A
	R. W. Gate Company	N/A
	Plasti-Fab	N/A

FLOOD GATES: LIMIT STAINLESS STEEL FLOOD GATES TO 2' AND SMALLER.

AIR SCRUBBERS

WWT-601: PLANT AIR SYSTEM



DESCRIPTION: Plant air systems remove corrosive gases, toxic vapors and odors.

SIZE	MANUFACTURER	MODEL #
	Purafil	N/A
	Pure Air	N/A

WWT-602: AIR FILTRATION CARBON

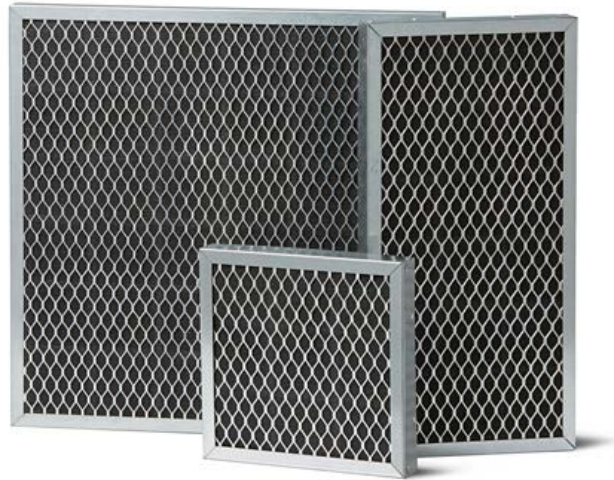

DESCRIPTION: Carbon media for handling odor and corrosive gases.

SIZE	MANUFACTURER	MODEL #
	MeadWestvaco	N/A
	Heyward Florida Incorporated	N/A

TANKS

WWT-701: FLAT ALUMINUM TANK COVERS

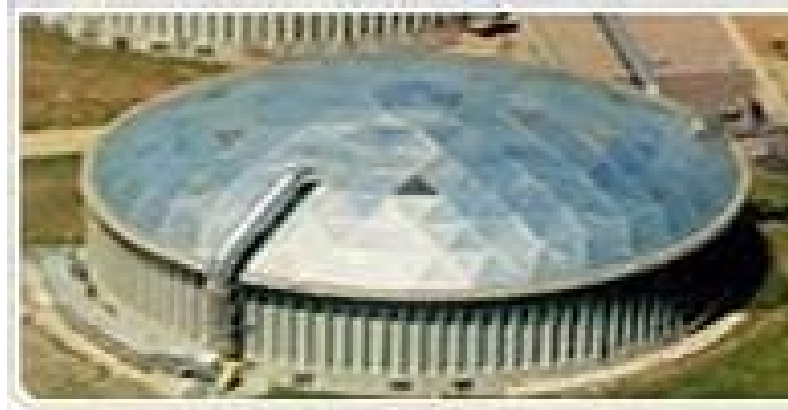

DESCRIPTION: Provides the strength, durability, odor control and protection for municipal and industrial water and wastewater applications.

SIZE	MANUFACTURER	MODEL #
	TEMCOR	N/A
	Conservatek Industries, Inc.	N/A

WWT-702: GLASS FUSED/STEEL TANKS



DESCRIPTION: This system is a storage tank made of sectional steel panels with glass molecularly bound (fused) to the steel surface. This provides a very durable, but flexible surface with excellent corrosion resistance, resulting in a tank, which can provide long life in a wide variety of applications.

SIZE	MANUFACTURER	MODEL #
	Aquastore	N/A

WWT-703: PRESTRESS STORAGE TANKS



DESCRIPTION: Tanks are designed and built to AWWA and ACI standards and are made of low maintenance materials: concrete, stainless steel and fiberglass.

SIZE	MANUFACTURER	MODEL #
	Crom	N/A
	Precon	N/A

WWT-704: FUEL TANKS



DESCRIPTION: Protected aboveground tank for flammable and combustible liquids.

SIZE	MANUFACTURER	MODEL #
	ConVault	N/A
	Phoenix	N/A
	JRS	

WWT-705: LINERS FOR CORROSION PROTECTION



DESCRIPTION: Protects wastewater infrastructure from corrosion.

SIZE	MANUFACTURER	MODEL #
	Spectra Shield	N/A

EFFLUENT FILTERS

WWT-801: CLOTH DISK FILTERS



DESCRIPTION: Fixed filter disk used in removing solids from liquids. Structure allows for high efficient filtration, low backwash volume and is a reusable element.

SIZE	MANUFACTURER	MODEL #
	AshBrook/Alafa Laval	N/A
	5-Star	N/A
	Aqua-Aerobics Aqua Disk	N/A

CENTRIFUGES

WWT-901: CENTRIFUGES

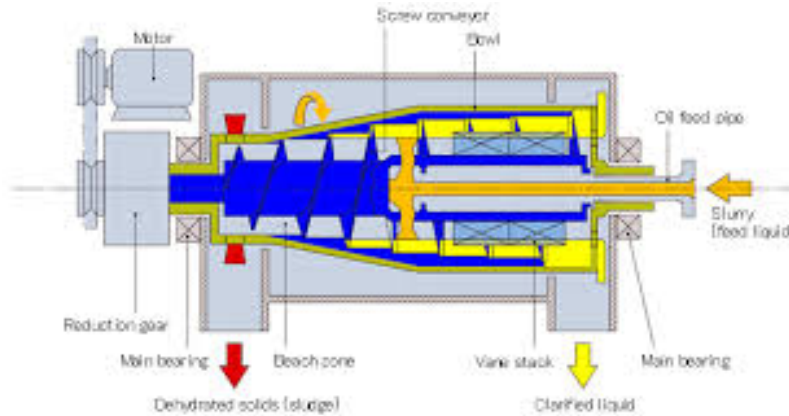

DESCRIPTION: Used for sludge dewatering needs. The centrifuge can remove the water content from sludge by rotating it at a high speed, so sludge can be disposed of in a cost-efficient manner.

SIZE	MANUFACTURER	MODEL #
	Humbolt/Andritz	N/A
	Hiller Separation & Process	N/A
	Alfa Laval	N/A

AERATION DIFFUSERS

WWT-1001: FINE BUBBLE DIFFUSERS



DESCRIPTION: Systems disperse the diffused gas volume to transfer an equivalent amount of oxygen as a coarse bubble system.

SIZE	MANUFACTURER	MODEL #
	Sanitaire	N/A

VALVE ACTUATORS

WWT-1101: ACTUATOR



DESCRIPTION: Allows for a valve to be automated.

SIZE	MANUFACTURER	MODEL #
	Rotork	N/A
	EIM	N/A
	Auma	N/A
	Limitorque	N/A
	Morin	N/A

CHEMICAL FEED SKIDS

WWT-1201: CHEMICAL METERING FEED PUMP SKID



DESCRIPTION: Designed to feed one or more chemicals into the system.

SIZE	MANUFACTURER	MODEL #
	Carl Eric Johnson	N/A
	Guardian Equipment	N/A
	Barrett Supply	N/A

FLOW METERS

WWT-1301: MAGNETIC FLOW METERS



DESCRIPTION: Inline instrument with no moving parts designed to measure the flow of a liquid through a pipe.

SIZE	MANUFACTURER	MODEL #
	Kronhe	Enviromag
	Endress and Hauser	Promag 53

WWT-1302: ULTRASONIC FLOW METERS



DESCRIPTION: Instrument attached to the outside of a pipe with no moving parts designed to measure the flow of a liquid through a pipe.

SIZE	MANUFACTURER	MODEL #
	Flexim Americas	Flexus

PUMPS

WWT-1401: CHEMICAL METERING PUMPS



DESCRIPTION: Pump designed to precisely pump and measure the flow of a liquid such as sodium hypochlorite, sodium hydroxide or other liquid chemicals.

SIZE	MANUFACTURER	MODEL #
	Alldoes/Grundfus	N/A

WWT-1402: RECYCLE/EFFLUENT PUMPS



DESCRIPTION:

SIZE	MANUFACTURER	MODEL #
	Flygt	N/A
	KSB	

WWT-1403: GRINDER PUMPS



DESCRIPTION:

SIZE	MANUFACTURER	MODEL #
	JWC	N/A
	Moyno	
	Franklin Miller	

WWT-1404: REUSE VERTICAL TURBINE PUMPS



DESCRIPTION: Centrifugal pumps specially designed to move water from an underground well or reservoir.

SIZE	MANUFACTURER	MODEL #
	Flowserve	N/A
	Goulds	
	Peerless	
	Aurora	

WWT-1405: SELF-PRIMING RAW SEWAGE PUMPS



DESCRIPTION: Designed with a large reservoir surrounding the pump casing which allows the pump to retain enough water internally to not need additional manual priming.

SIZE	MANUFACTURER	MODEL #
	Gorman Rupp	N/A

WWT-1406: PROGRESSIVE CAVITY PUMPS

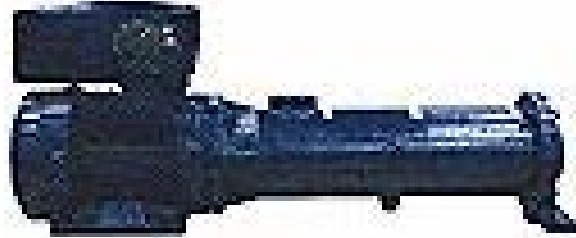

DESCRIPTION: A positive displacement pump that transfers fluid by means of the progress, through the pump, of a sequence of small, fixed shape, discrete cavities, as its rotor is turned.

SIZE	MANUFACTURER	MODEL #
	Moyno	N/A
	Seepex	

WWT-1407: VACUUM PUMP



DESCRIPTION:

SIZE	MANUFACTURER	MODEL #
	Nash_Elmo	N/A
	Busch USA	N/A

VALVES

WWT-1501: PLUG VALVES



DESCRIPTION:

SIZE	MANUFACTURER	MODEL #
	Crispin K-Flow Valve	Series 800
	Kennedy Full Port	N/A

WWT-1502: CHECK VALVES



DESCRIPTION:

SIZE	MANUFACTURER	MODEL #
	Crispin SWC Series Swing	N/A
	Kennedy	N/A
	Clow	N/A

WWT-1503: BALL VALVES



DESCRIPTION:

SIZE	MANUFACTURER	MODEL #
	Flo-Tite	N/A

VALVE POSITION MONITOR

WWT-1601: ROTARY POSITION MONITOR



DESCRIPTION:

SIZE	MANUFACTURER	MODEL #
	Westlock	AccuTrak 9358/9044

CONVEYOR

WWT-1701: CONVEYOR SYSTEM



DESCRIPTION:

SIZE	MANUFACTURER	MODEL #
	BW Sinclair	N/A

INSTRUMENTATION

GENERAL

SCOPE OF INSTRUMENTATION DOCUMENT:

Approved Manufacturers and list of Standard instrumentation does not include specialized instrumentation and/or accessories required for the approved items below. Specialized instrumentation/accessories are site specific and shall be added to the approved instrument as needed.

APPROVED MANUFACTURERS

Hach

Wallace & Tiernan

Cerlic

Rosemount

ISCO

Sigma

Endress Hauser

Krohne

Kurz

Fluid Components International

Milltronics

GP:50

Red Valve

ANALYZERS

TYPE	MANUFACTURER	MODEL #
Nitrate/Nitrite Analyzers	Hach	Analyzer 557
Ammonia Analyzers	Hach	Analyzer 517
Chlorine Analyzer	Hach	Hach CL17
Chlorine Analyzer	Wallace & Tiernan	Depolox
Phosphate Analyzer	Hach	Hach Phosphax
Chlorine Analyzer (colorimetric)	Hach	CL17 series (total or free)
Chlorine Analyzer (amperometric)	Hach	CL10 series (total or free)
Phosphate Analyzer Sampler	Hach	PHOSPHAX SC
Turbidity/TSS Analyzer	Solitax	TSS Sensor
Turbidity/TSS Analyzer	Hach	Highline sc SS wiper w/sc 200

CONTROLLERS

TYPE	MANUFACTURER	MODEL #
Controller sc200	Hach	2 Inputs and Profibus
Controller sc1000	Hach	4 inputs and Profibus DP
Nitrate/Nitrite Controller	Hach	HACH Amtax SC1000
Ammonia Analyzers Controller	Hach	HACH Amtax SC1000
UV Transmittance Controller	Hach	SC 100 Item
Suspended Solids Controller	Cerlic	BB2 Control Box

PROBES

TYPE	MANUFACTURER	MODEL #
Ammonia Probe	Hach	Hach NH4D Ammonia Sensor
DO Probes	Hach	LDO Probe
DO Probes Controller	Hach	SC 100
pH Probes	Hach	pHD sc, Differential pH Digital Sensor
pH Probes	Rosemount	Solucomp II Analyzer
Sludge Level Probe	Hach	Sonatax sc Probe

SAMPLERS

TYPE	MANUFACTURER	MODEL #
Refrigerated Sampler	ISCO	6712FR
Refrigerated Sampler	ISCO	5800
Refrigerated Sampler	Sigma	
Sample Conditioning Filter System	Hach	Filtra
Ammonia Analyzer Sampler	Hach	AMTAX SC
Samplers	Hach	AS950 series

SENSORS

TYPE	MANUFACTURER	MODEL #
TSS Sensor	Cerlic	ITX Suspended Solids
TSS Sensor	Hach	Hach
MLSS Sensor	Hach	Hach Solitax Solids Analyzer
Turbidity Sensor	Hach	Hach Solitax Turbidity/TSS
Nitrate/Nitrite Sensor	Hach	NITRATAX Plus SC
Ammonia Sensor	Hach	AISE sc Ammonium probe with RFID Technology
Dissolved Oxygen Sensor/Probe	Hach	LDO Model 2
Differential pH Sensor	Hach	pHD SC
UV Absorb/Trans Sensor	Hach	UVAS Plus SC Suspended Solids/Turbidity Sensor Hach
Suspended Solids/Turbidity Sensor	Hach	SOLITAX SC
Conductivity Sensor	Hach	3700 Inductive Conductivity Sensor
ORP Sensor	Hach	ORP Differential Sensor
Suspended Solids Sensor	Cerlic	LC sensor
UV Transmittance	Hach	UVAS sc sensor
pH Sensor	Rosemount	Solucomp II Analyzer
Pressure	Red Valve	series 48

TRANSMITTERS

TYPE	MANUFACTURER	MODEL #
Pressure Transmitter - Air	Rosemount	
Temperature Gauge - Air	Rosemount	
Level Transmitters	Milltronics	Hydro Ranger
Level Transmitters	GP:50	
Pressure Transmitter	Rosemount	
Temperature Transmitter	Rosemount	
Force Main Pressure Transducer	Automation Products Group (APG)	PT500A
Potable Water Pressure Transducer	Automation Products Group (APG)	PT500Am

WATER TREATMENT PLANT APPROVED MATERIALS

PROTECTIVE COATINGS

WT-101: PROTECTIVE COATING



DESCRIPTION:

COMPANY NAME	CONTACTS	PHONE	EMAIL	APPROVED MATERIALS
The Sherwin-Williams Company	Josh Hinson	904-591-3137	swrep4538@sherwin.com	*Dura-Plate 2300 *Dura-Plate UHS *Dura-Plate UHS Primer *Steel Seam FT910 *Loxon XP(smooth) *GP3830 Resuprime MVT Primer GP3741 Novo-Flo Epoxy
Tnemec Co.				*Series 218 *Series 215 *Series 20HS *Series 22 *Series 156 Enviro-Crete *Series 201 Epoxoprime *Series 282 Tneme-Glaze

OIL

WT-201: OIL



DESCRIPTION:

COMPANY NAME	CONTACTS	PHONE	EMAIL	APPROVED MATERIALS
Lubrication Engineers, Inc.				Monolec Turbine Oil

SLEEVE BEARINGS AND MECHANICAL SEALS

WT-301: SLEEVE BEARINGS



DESCRIPTION:

COMPANY NAME	CONTACTS	PHONE	EMAIL	APPROVED MATERIALS
Vesco Plastics				Vesconite HiLube

WT-302: MECHANICAL SEALS



DESCRIPTION:

EQUIPMENT	TYPE	MANUFACTURERS/MODEL
Mechanical Seals	Cartridge Split-Type	*The John Crane Company *Chesterton

PUMPS

WT-401: PUMPS



DESCRIPTION:

PUMP TYPE	TYPES or ADD-ONS	MANUFACTURERS
Well Pump	Discharge head motor and column package	<ul style="list-style-type: none"> *Flowserve Corporation * Goulds Water Technology * Peerless Pumps * National Pump Company * American-Marsh Pumps * Aurora Pumps
High Service Pumps	Horizontal, Split Case, Centrifugal	<ul style="list-style-type: none"> * Goulds Water Technology * Aurora Pumps * Peerless Pumps * American-Marsh Pumps * Flowserve Corporation
Sump Pumps	Cast Iron Body	<ul style="list-style-type: none"> * Flygt * Hydromatic
Sodium Hypochlorite Metering Pumps		<ul style="list-style-type: none"> * Grundfos Pumps Corp * SMART Digital DDA with E-Box for Profibus Connectivity
Sodium Hypochlorite Pump Skid System		<ul style="list-style-type: none"> *Class Engineering Inc *Guardian Equipment Inc *Blue Planet Environmental Systems, Inc.

ELECTRICAL-ELECTRONICS-INSTRUMENTATION

WT-501: ELECTRICAL EQUIPMENT



DESCRIPTION:

EQUIPMENT	TYPES or ADD-ONS	MANUFACTURERS/MODEL
MCC		* Eaton * Schneider Electric * Siemens
VFD		* Siemens G120X * Danfoss Aqua Drive * ABB ACQ580 * Schneider Altivar Process ATV630 * Toshiba VF-AS3
Power Monitoring Equipment – Remote Applications		* Siemens PAC3200
Power Monitoring Equipment – Local Applications		* Siemens PAC4200 as provided by Switchgear manufacturer
Power Generators		JEA Contract Supplier
Automatic Transfer Switch		* ASCO 7000 Series
Switchgear		JEA Contract Supplier
Soft Starters		* Eaton S811+ * Siemens 3rw55

WT-502: INSTRUMENTATION EQUIPMENT



DESCRIPTION:

EQUIPMENT	TYPES or ADD-ONS	MANUFACTURERS/MODEL
Manual Pressure Gauge	Raw Water Pump	* Ashcroft XLL Performance Plus! (4.5")
Electronic Pressure Transmitter	Raw Water Pump	* Rosemount 3051 TG2A
Pump Check Valve Limit Switch	Raw Water Pump	* Provided by valve manufacturer
Conductivity Element and Transmitter	Raw Water Pump	* Rosemount Model 228 * Sensor and Model 1056 * Transmitter, Endress Hauser Memosens CLS82D and Liquiline CM442 Transmitter
Flow Element and Transmitter	Raw Water Pump	* Endress Hauser W500, ABB WaterMaster
Level Element and Transmitter	Raw Water Pump	* Probe: PMC MTM 3213 Controller: Endress Hauser RIA46
Level Element and Transmitter	Ground Storage Tank/Ultrasonic	* Probe: Siemens SITRANS Probe LU (7ML52212DA14) * Controller: Siemens HydroRanger 200 * Radar: Magnetrol R-82
Level Element and Transmitter	Ground Storage Tank/Hydrostatic Pressure	* Rosemount 3051C



Level Element and Switch Electrodes	Ground Storage Tank	* B/W Controls, Inc. * Charles F. Warrick Co.
Junction Boxes	Ground Storage Tank	316 SST, NEMA 4X
Free Chlorine Residual Analyzer and Transmitter #1	High Service Pump Room	* Endress Hauser Liquiline CM444
Free Chlorine Residual Analyzer and Transmitter #2	High Service Pump Room	* Wallace & Tiernan Model DEPOLOX 400M
Pressure Gauge-Vacuum Gauge	High Service Pump Room	* Ashcroft XLL Performance Plus! (4.5")
Pump Check Valve Limit Switch	High Service Pump Room	* Provided by valve manufacturer
Level Float	High Service Pump Room	* As supplied by pump manufacturer

WT-503: ELECTRONIC EQUIPMENT



DESCRIPTION:

EQUIPMENT	TYPES or ADD-ONS	MANUFACTURERS/MODEL
Exhaust Fans, MAU, AHU	Hypochlorite Storage Tank	* Siemens
Level Element and Transmitter	Hypochlorite Storage Tank	* Mercold EDAW-N1E1-02T1 with Marquest Scientific Tuff Guard
Horn, Indoor/Outdoor	Hypochlorite Storage Tank	* Federal Signal Corp Model 50GC with Universal Tone Module (UTM)
Optical Leak Detection	Hypochlorite Storage Tank	As supplied by tank manufacturer
PLC – Water Plant	Electrical Room	* Siemens S7-400
PLC	Raw Water Pump	* Siemens S7 Series 300
PLC – As needed and approved by JEA	Electrical Room	* Siemens S7-1200 * Siemens S7-1500
PLC – Remote Wells	Electrical Room	* Siemens S7-300
UPS	Electrical Room	* Orion 2000KVA w/ relay card
Power Meter	Electrical Room	* Siemens PAC3200 w/ Profibus expansion model
Panel	Steel and FRP panel enclosures	* Hoffman * Schaffer
HMI	Outdoor local panel display	* Siemens SIPLUS TP700 Comfort Outdoor HMI
HMI	Indoor local panel display	* Siemens Simatic HMI, TP 1200 Comfort

HMI Software	Version to be verified with JEA	* Siemens WinCC SCADA (TIA portal)
Profibus Connector with LEDs		* VIPA 972 Series
Communication Interface Units		* CIU ISO 150 for Profibus DP
Profibus Multirepeater		* VIPA 920 Series
DIN-rail power supplies for 1-phase systems		* Puls CP10.241 Series
Converters		* Puls PISA 11 Series
Ethernet Switch		* N-Tron 106FX2
Surge Protection		* Citel
Surge Protection	Surge protection for 24v 4-20 mA signals	* PR Electronics Universal Transmitter Model 4114 with model 4501 display

STORAGE TANKS

WT-601: STORAGE TANKS



DESCRIPTION:

EQUIPMENT	TYPES or ADD-ONS	MANUFACTURERS/MODEL
Ground Storage Tank	Accessories	* Crom * Precon Corporation
Crosslinked Polyethylene Storage Tank		* Poly Processing Co * Assmann Corp.

FANS

WT-701: FANS AND INTAKE HOOD



DESCRIPTION:

EQUIPMENT	TYPES or ADD-ONS	MANUFACTURERS/MODEL
Ground Storage Tank	Fans and Intake Hood	* Aerovent (supplied by Markair, Inc)

FLOW METERS

WT-801: FLOW METERS AND RELATED EQUIPMENT



DESCRIPTION:

EQUIPMENT	TYPES or ADD-ONS	MANUFACTURERS/MODEL
Flow Element Venturi Tube Insert or Electromagnetic Flowmeter		*Endress Hauser W500 *Krohne Waterflux 3300 with IFC 300
Pressure Differential Transmitter	Electronic	*Rosemount Model 3051C
Pressure Gauge		*Ashcroft CLL Performance First (4.5")
Wallmount Enclosure and Back Panel	4X Polyester PJW Series, FRP	*Hammond Manufacturing
Flow Element and Transmitter		*Flexim Fluxus F501

VALVES

WT-901: AIR RELEASE/VACUUM VALVES



DESCRIPTION:

TYPE	SIZE	PROCESS LOCATION	MANUFACTURERS /MODEL
Air Release Valve	1" and larger	High Service Pump Station	*Val-Matic *Crispin
Air/Vacuum Valve	1" and smaller	Raw Water Well Pump	*Val-Matic "SuperValve"
Air/Vacuum Valve	2" and larger	Raw Water Well Pump	*Val-Matic
Angle Pattern Hose Valve	1"-3"	Chemical Building Portable Water System	*Powell "Fig 1254" *Walworth "Fig 8907F"
Angel Type Hose Valve	¾"	Raw Water Well Pump Sample Tap	*Milwaukee "504" *Stockham "B-216" *Walworth "Fig 3059"
Back Pressure Valve	1" and smaller	Plant Service Water	*Cash Valve 13690
Back Pressure Valve	1" and smaller	Sodium Hypochlorite Metering Pump Discharge	*Griffco
Back Pressure Valve	3" and smaller	Sodium Hypochlorite Injection	*Plast-O-Matic

WT-902: BALL VALVES



DESCRIPTION:

TYPE	SIZE	PROCESS LOCATION	MANUFACTURERS /MODEL
Ball valve	2" and smaller	Hose Station/Potable Water System	*Conbraco Ind. "Apollo 70-100 Series" *Powell "Fig 42101" *Stockham "S-216"
Ball Valve	2" and smaller	Raw Water Well Pump Pitometer/Water Heater	*Conbraco Ind Apollo 70-100 Series" *Powell "Fig 42101" *Stockham "S-216"
Ball Valve	2" and smaller	Chlorine Residuel and pH analyzer	*ASAHI True Union
Ball Valve	3" and smaller	Sodium Hypochlorite Systems	*ASAHI True Union
Ball Valve	3" and smaller	Raw Water Well Pump/High Service Pump Station/Finished Water Venturi/Flowmeter Vault	*Conbraco Ind "Apollo 76F Series"
Ball Check Valve	3" and smaller	Chlorine Injection Vault	*ASAHI True Union

WT-903: BUTTERFLY VALVES



DESCRIPTION:

TYPE	SIZE	PROCESS LOCATION	MANUFACTURERS /MODEL
Butterfly Valve	6" and larger	Raw Water Well/High Service Pump Station	*GA Series 800 *Val-Matic 2000 Series
Butterfly Valve	6" and larger	Raw Water Well/High Service Pump	*GA Series 800, worm gear with handwheel *Val-Matic 2000 Series with handwheel

WT-904: CHECK VALVES



DESCRIPTION:

TYPE	SIZE	PROCESS LOCATION	MANUFACTURERS /MODEL
Check Valve	4" and smaller	Sodium Hypochlorite Line	*ASAHI True Union
Check Valve	3" and larger	Sanitary Lift Station	*Milwaukee F-2974 *Stockham G-931
Check Valve	4"-24"	High Service Pump Raw Water Well	*Val-Matic, Surge-buster *GA 200-D
Check Valve	As required by line size	Ground Storage Tank	*Plast-O-Matic "Series CK" *Series VB Vacuum Breakers *Red Valve

WT-905: GATE VALVES



DESCRIPTION:

TYPE	SIZE	PROCESS LOCATION	MANUFACTURERS /MODEL
Gate Valve	3" and smaller	Backflow Preventer Assembly	
Gate Valve	4"-24"	Ground Storage Tank Potable Water Lines Finished Water Flow Meter High Service Pump Fire Hydrant Shut Off Valve Overflow Discharge Lines	*American Flow Control "2500 Series" *AVK (S/S Stem) "Series 45" *Clow Valve "F- 6100" *Kennedy "8571" *Mueller "A2360, A2361" *M&H "4067" *US Pipe "250" *United Water Products "2010" American-RD "D100"

WT-906: PRESSURE REGULATING VALVES



DESCRIPTION:

Pressure Reducing Valve	2 ½" and smaller	Chlorine Residual and pH analyzer	*DanFoss Flomatic C150E
Pressure Reducing Valve	2" and smaller	Chemical Building	*DanFoss Flowmatic C101
Pressure Reducing Valve	2"-16"	WTP Discharge	*Bermad "720" *Watts-F115 DanFoss *Flomatic C401
Pressure-Reducing Valve	2" and smaller	Chlorine Residual and pH Analyzer	
Pressure Relief Valve	1" and smaller	Sodium Hypochlorite Metering Pump	
Pressure Regulating Valve	1" and smaller	Sodium Hypochlorite Metering Pump Discharge	*Plast-O-Matic
Reduced Pressure Backflow Preventer	4" and larger	Chemical Building Potable Water System	*DanFoss Flowmatic RPZ

WT-907: MISC. VALVE TYPES



DESCRIPTION:

TYPE	SIZE	PROCESS LOCATION	MANUFACTURERS /MODEL
Globe Valve	3" and smaller	Chemical Building	*Milwaukee "502" *Stockham "B-16" *Walworth "Fig 3058"
Plug Valve	3"-12"	Sanitary Lift Station	*APCO, Series 500
Fire Hydrant	5 ¼ Main Valve, 6" Bottom Connection	Yard Piping	*American MK-73 *Clow Valve F-2545 *Kennedy K81A *Mueller A-421 *US Pipe Met 250/M94 *Waterous WB-77

MISCELLANEOUS

WT-1001: MISC MATERIALS



DESCRIPTION:

EQUIPMENT	TYPE	MANUFACTURERS/MODEL
Chemical Tubing/Hose		*Pacific Echo Spiralite Spa-Flex
Chemical Injection Assembly		*Hydro Instruments
Fiberglass Grating		*Fibergrate *Strongwell
Asset Bar Code Stickers Used in ALL W/WW applications	AT-3089P-B HTC Clde: 48.10.00.00 Adder: +3M 468MP Adhesive	MyAssetTag www.myassettag.com Alisha Parke alisha@smartsign.com