

WATER & RECLAIMED CONSTRUCTION DETAILS

TABLE OF CONTENTS

DETAIL PLATE

NUMBER

DESCRIPTION:

W – 1Water Service Installations 2” and Smaller Meter

W – 2Water Service Detail 2” and Smaller Meter

W – 3Meter Box & Cover for 1” and Smaller Meters

W – 3AMeter Box Polymer Cover Model No. 37 – Two Hole

W – 3BMeter Box Polymer Cover Model No. 37 – One Hole

W – 4Water Meter Box & Cover for 1-1/2” & 2” Meters

W – 4AWater Meter Box Polymer Concrete Cover Model No. 65 – Two Hole

W – 5Large Water Meter Installations

W – 6Water Meter Installation Details (3” – 20” Meters)

W – 7Co-Polymer Water Meter Box 36”x60”x 48” (3” & 4” Meters)

W – 7ACo-Polymer Water Meter Box 48”x72”x48” (4” & 6” Meters)

W – 7BCo-Polymer Water Meter Box 48”x96”x48” (6” – 20” Meters)

W – 8Water Meter Box Dimensions (3” – 20” Meters)

W – 9Water Service Manifold Arrangement

W – 10Separation Requirements for Water Mains

W – 11Notes on Utility Separation Requirements – Water

W – 12Fire Hydrant Installation Using Tapping Sleeve & Valve

W – 13Fire Hydrant Installation Using Mechanical Joint Tee

W – 14Fire Hydrant Installation Limited Space

W – 15Cross Connection Control Device Where Reclaimed Water is Available

W - 15A..... Cross Connection Control Device For Irrigation Service Connections

W – 16Water System Valve Box Cover

W – 17Water System Valve Box

W – 18Water Valve Installation Detail

W – 19Water Valve Jacket Adjusted After Roadway Re-Surfacing

W – 20Bridge Deck Pipe Hanger Detail

W – 21Sidewall Pipe Hanger Detail

W – 22Pipe Support & Pole Assembly for Water Main

W – 23Pipe Support Details for Pole Assembly

W – 24Temporary Sample Tap – Alternative Methods

W – 25Temporary Sample Tap

W – 262” Temporary Sample Tap for Stub Out

W – 27Temporary Sample Tap for In-service Mains

W – 28Flushing Valve Below Grade

W – 29NOT USED

W – 30Typical Casing Detail – Water



W – 30A.....Typical Split Casing Detail-Water
W – 31A.....PVC Pipe Restraint Joint Schedule
W – 31B.....D.I.P. Restraint Joint Schedule
W – 31C.....Mechanical Restraint Details – I
W – 31D.....Mechanical Restraint Details – II
W – 32.....Adjustment Over Existing Utilities – Mechanical Restraints
W – 33.....Adjustment Over Existing Utilities Using Tie Rods
W – 34.....Adjustment Under Existing Utilities – Mechanical Restraints
W – 35.....Adjustment Under Existing Utilities Using Tie Rods
W – 36.....Plugged Dead End Using Tie Rods
W – 37.....Plugged Dead End Using Mechanical Restraints
W – 38.....Thrust Block Size Chart
W – 39.....NOT USED
W – 40.....Adjustment Under Existing Utilities Pipe Joint Deflection
W – 41.....Adjustment Over Existing Utilities Pipe Joint Deflection
W – 42.....Open Cut Trench For Pressure Pipe
W – 42A.....Open Cut Trench For Pressure Pipe FDOT ROW
W – 43.....Fusible PVC Bending Radius and Pulling Force for HDD Pipe
W – 43A.....Dual Directional Drilling
W – 44.....Locate Wire Construction For Water Systems
W – 44A.....Locate Wire For Branchmain & Large Services
W – 44B.....Locate Wire Box
W – 45.....Swabbing Port and Clean out Vault Section
W– 45A.....Swabbing Port and Clean out Vault Plan
W – 45B.....Swabbing Launching Station Detail for New Force Main Up to 24”
W – 45C.....Swabbing Launching Station Detail for New Force Main Up to 24” - Plan
W – 45D.....Swabbing Launching Station Detail for New Force Main Up to 24” - Section

A LOCATE WIRE SHALL BE PLACED ON SERVICES 10FT OR GREATER.

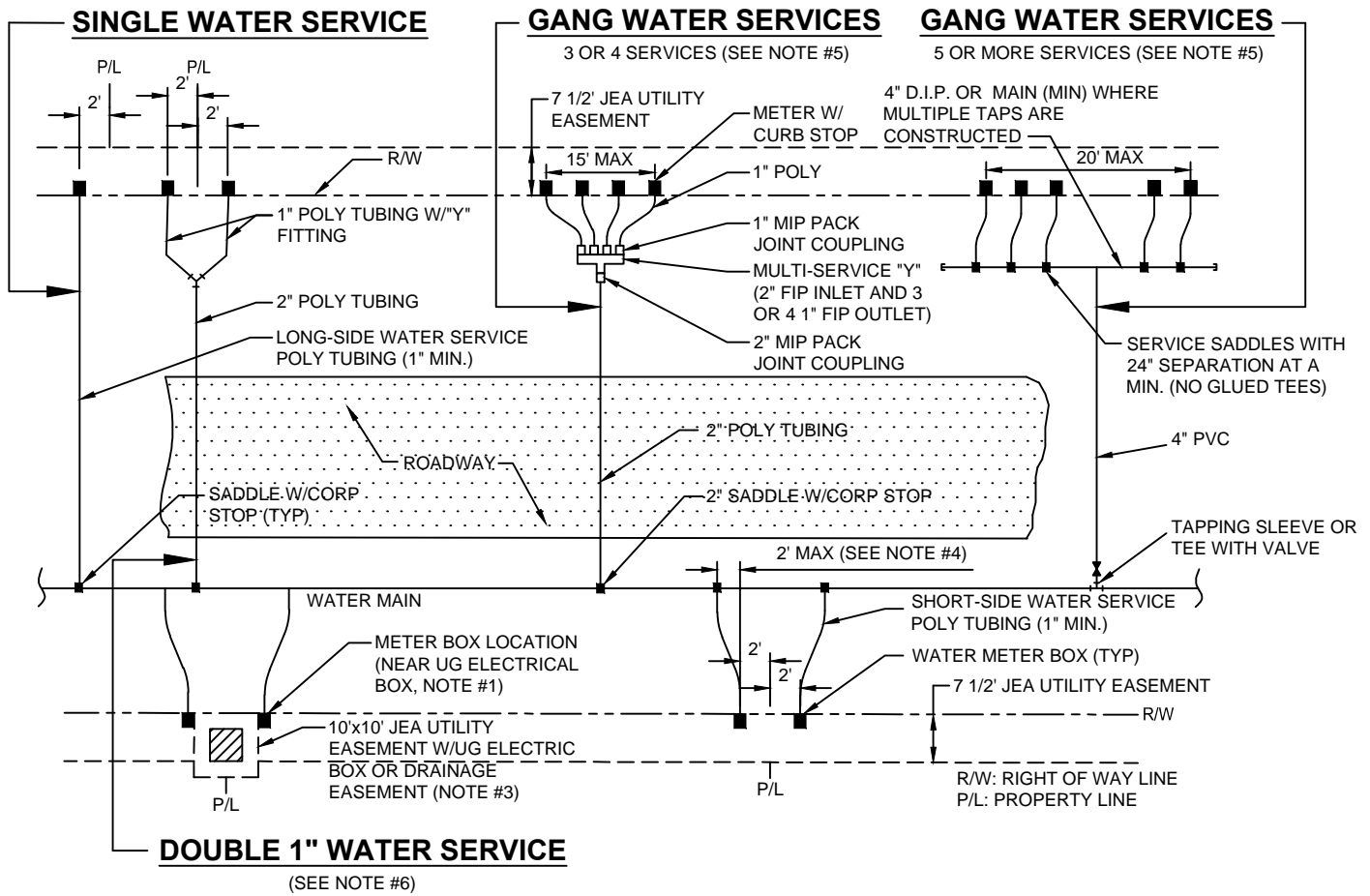

NOTES :

1. THE SKETCHES ABOVE INDICATE TYPICAL WATER SERVICE AND METER BOX LOCATIONS. ACTUAL LOCATIONS OF BOXES MAY VARY SLIGHTLY ACCORDING TO FIELD CONDITIONS ENCOUNTERED. TYPICALLY, THE METER BOX SHALL LOCATED AT THE R/W LINE BUT INSIDE THE 7 1/2" ELECTRIC EASEMENT.
2. UNLESS SPECIFIED OTHERWISE BY THE APPLICABLE COUNTY (NASSAU, CLAY OR ST. JOHNS COUNTY), THE METER BOX SHALL BE LOCATED IN THE JEA 7 1/2" UTILITY EASEMENT, AND TWO FEET INSIDE OF THE PROLONGATION OF ONE OF THE SIDE PROPERTY LINES. IF A CONFLICT EXISTS WITH OTHER UTILITIES, THE METER BOX MAY BE ADJUSTED TO FOUR FEET (MAX.) INSIDE PROPERTY LINES (IN LIEU OF TWO FEET). UNLESS APPROVED OTHERWISE BY JEA, THE WATER METER BOX SHALL BE LOCATED IN NON-TRAFFIC AREAS (NOT IN SIDEWALKS OR DRIVEWAYS). IF THE METER BOX IS APPROVED BY JEA TO BE LOCATED IN A DRIVEWAY OR SIDEWALK, THEN THE CONSTRUCTION SHALL MEET STANDARD DETAIL NUMBERS W-3&4, AT A MINIMUM (SEE W-3 AND W-4 FOR THE REQUIREMENTS OF SPECIAL ORDER POLYMER BOX AND TOP) . SET TOP OF BOX AT FINISHED GRADE. IF AN UNAPPROVED METER BOX IS IDENTIFIED BY JEA, THEN THE CONTRACTOR OR CUSTOMER SHALL BE RESPONSIBLE FOR THE COST OF RELOCATING ANY METER BOX WHICH IS LOCATED IN THE SIDEWALK OR DRIVEWAY OR THE COST TO PROVIDE THE CORRECT METER BOX. JEA SHALL APPROVE ALL DEVIATIONS TO THE ABOVE PRIOR TO CONSTRUCTION.
3. IF DRAINAGE OR OTHER EASEMENT LOCATED BETWEEN LOTS, METER BOXES SHALL BE LOCATED AT THE EASEMENT LINE BUT OUTSIDE THE EASEMENT AREA.
4. FOR SINGLE SERVICES, THE HORIZONTAL DISTANCE (PERPENDICULAR TO THE MAIN) BETWEEN THE SERVICES SADDLE AND THE METER BOX SHALL BE 2 FEET MAXIMUM. FOR DOUBLE 1" SERVICES, THE 2" POLY MAIN SHALL BE LOCATED CENTERED BETWEEN THE TWO METER BOXES. LOCATE WIRE IS REQUIRED ON ALL SERVICES 10' OR GREATER IN LENGTH. IF LOCATE WIRE IS REQUIRED, THE WIRE SHALL RUN FROM THE METER BOX (W/ PIG TAIL) TO THE MAIN (DEAD END SHALL BE TAPED WITH NO CONNECTION TO MAIN WIRE WITH THE LAST 24 INCHES STRIPED OF INSULATION/BARE WIRE AS GROUND). ALL EXCEPTIONS TO THIS REQUIREMENT MUST BE APPROVED BY JEA. THIS WILL ASSIST IN LOCATING EXISTING SERVICE LINES IN THE FUTURE.
5. GANG WATER SERVICES: FOR 3 OR 4 SERVICES IN ONE AREA, A DUCTICLE IRON PIPE (D.I.P.) WATER MAIN EXTENSION W/LOCATE WIRE MAY BE UTILIZED ON EITHER SHORT-SIDE OR LONG SIDE SERVICES WHERE SHOWN ON THE DRAWINGS. LOCATE WIRE SHALL EXTEND FROM ONE METER BOX TO CORP STOP AT WATER MAIN. FOR 5 OR MORE SERVICES IN ONE AREA, A WATER MAIN EXTENSION W/LOCATE WIRE MAY BE UTILIZED ON EITHER SHORT-SIDE OR LONG SIDE SERVICES WHERE SHOWN ON THE DRAWINGS (TAPS STAGGERED AND AT 2 FEET ON CENTER-MIN). FOR WATER SUPPLY HEADERS WHERE 5 OR MORE TAPS ARE CONSTRUCTED, THE HEADER PIPE SHALL BE 4" AT A MINIMUM. EXAMPLE: CONSTRUCT A 4" MAIN PVC CROSSING THE STREET FOR 5 RESIDENTIAL CUSTOMERS, UTILIZING 4" DIP, 4" PIPE, 4"x1" SADDLES AND 1" CORP STOPS (NO GLUED TEE FITTINGS). THE 4" OR LARGER D.I.P. WATER MAIN MUST BE SIZED AND DESIGNED BY THE P.E. ENGINEER.
6. DOUBLE 1" WATER SERVICES IS ALLOWED FOR SHORT SIDE OR LONG SIDE SERVICES AND WHERE SHOWN ON THE DRAWINGS.
7. A 1" IRRIGATION SERVICE MAYBE TAPPED INTO THE (1" MIN) DOMESTIC WATER SERVICE LINE (WHICH SERVES THE SAME CUSTOMER) UTILIZING A 1" BRONZE "Y" FITTING. (IN AREAS WHERE NO RECLAIMED WATER IS AVAILABLE).
8. No 2" AND SMALLER WATER SERVICE TAPS PERMITTED ON WATER MAINS WHICH ARE 20" AND LARGER SIZE.
9. RECLAIMED WATER METER BOXES OR SERVICES SHALL BE CONSTRUCTED SIMILAR TO THE ABOVE AND SHALL BE LOCATED, AT A MIN. OF 10' FROM THE POTABLE WATER SERVICE, AND/OR BOX AND NOT ALLOWED IN CONCRETE OR ASPHALT UNLESS APPROVED OTHERWISE BY JEA.
10. SERVICE SIZE SHALL BE SAME AS THE METER SIZE.

WATER OR RECLAIM SERVICE INSTALLATIONS

2" AND SMALLER METER

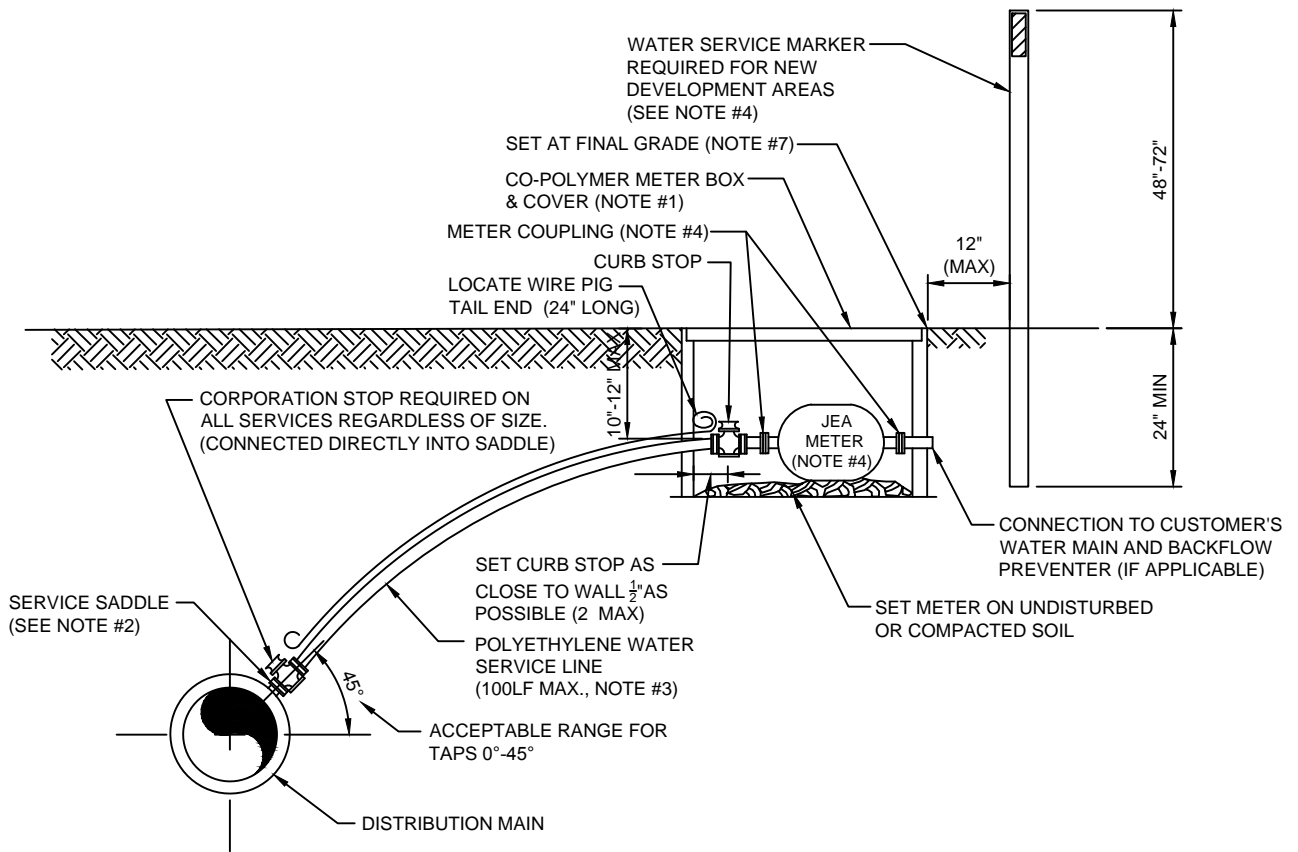

NOTES:

1. SEE PLATE W-1 FOR METER LOCATION REQUIREMENTS.
2. SINGLE BAND SADDLES SHALL BE UTILIZED ON NEW 1" WATER SERVICES WHICH ARE INSTALLED ON A DRY 10" SIZE OR SMALLER WATER MAIN (NEW WATER MAIN CONSTRUCTION). FOR WET TAPS OR WATER MAINS 12" SIZE AND LARGER, A DOUBLE BAND SADDLE IS REQUIRED. BRASS SADDLES MAY BE UTILIZED ON NEW 1 INCH AND SMALLER WATER SERVICES WHICH ARE INSTALLED ON A DRY 10 INCH OR SMALLER PVC WATER MAIN.
3. NO OPEN CUT UNDER ROADWAY PAVING ALLOWED UNLESS THE ROADWAY IS BEING RECONSTRUCTED OR IF DIRECTED OTHERWISE BY J.E.A. CONSTRUCT POLY LINE WITH 24" (MIN.) COVER UNDER ROADWAYS. THE POLY WATER SERVICE LINE SHALL BE SAME SIZE AS THE METER (1" MINIMUM) AND BE INSTALLED PERPENDICULAR TO THE MAIN AND NOT EXCEED 100LF UNLESS APPROVED OTHERWISE BY JEA.
4. INSTALL PVC PLUG IN ALL CURB STOPS IF WATER SERVICE IS "NOT IN USE" (I.E.: IF NO METER IS INSTALLED). WATER SERVICES SERVING VACANT LOTS (SERVICE NOT IN USE), SHALL INCLUDE A "W" CUT INTO THE CURB (CLOSEST TO THE METER BOX), AND PAINTED BLUE (PAINTED PURPLE FOR RECLAIMED WATER). IN ADDITION, FOR NEW DEVELOPMENT AREAS WHERE THE WATER SERVICE IS "NOT IN USE", A LANDSCAPE TIMBER OR 3x3 MIN. P.T. POST (TOP PAINTED BLUE OR PURPLE FOR RECLAIMED WATER). THE REMOVAL OR TRANSFER OF A WATER SERVICE SHALL INCLUDE BRASS METER COUPLINGS (HEX ON BARREL TYPE).
5. NO 2" AND SMALLER WATER SERVICE TAPS PERMITTED ON WATER MAINS WHICH ARE 20" AND LARGER SIZE.
6. THE CONTRACTOR SHALL BE RESPONSIBLE FOR THE REPAIR OR REPLACEMENT OF THE METER OR ELECTRONIC DEVICES IF DAMAGED BY THE CONTRACTOR DURING THE CONSTRUCTION PERIOD.
7. METER BOX AND TOP SHALL BE CLEAR OF ALL DEBRIS TO ALLOW FULL ACCESS TO BOX (I.E. NO DIRT, TRASH OR OTHER DEBRIS PLACED ON TOP OF BOX).
8. LOCATE WIRING REQUIRED ON ALL SERVICES 10' OR GREATER IN LENGTH. SEE PLATE W-44.

WATER SERVICE DETAIL- 2" AND SMALLER METER

JANUARY 2018

PLATE W-2

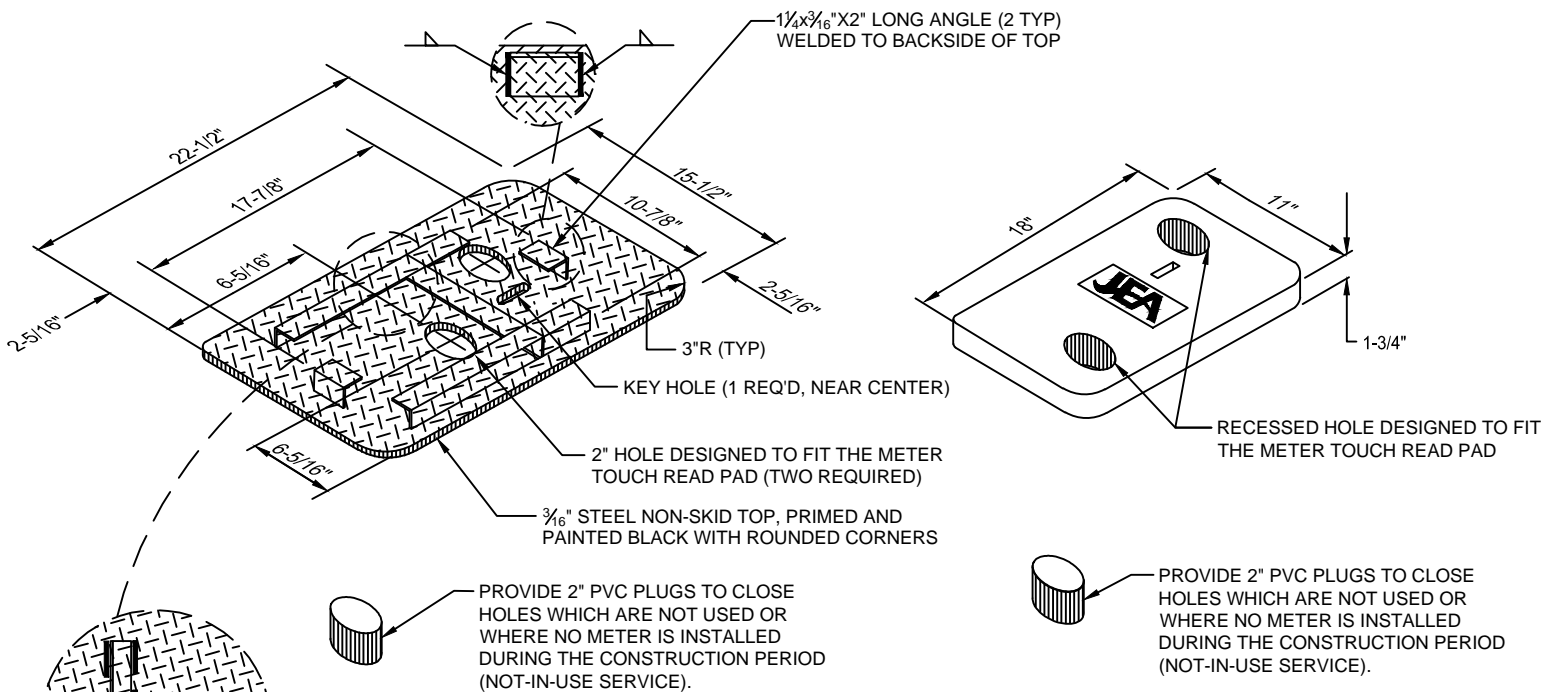

METAL TOP
(SEE NOTE #4)

POLYMER TOP
(SEE NOTE #1)

CONSTRUCT WITH 1 1/4" ANGLE (STEEL 3/16" THK),
12" LONG WITH CENTER STIFFENER

PROVIDE 2" LONG (ZIPPER) WELDS ON
BOTH SIDES OF ANGLE (TYP)

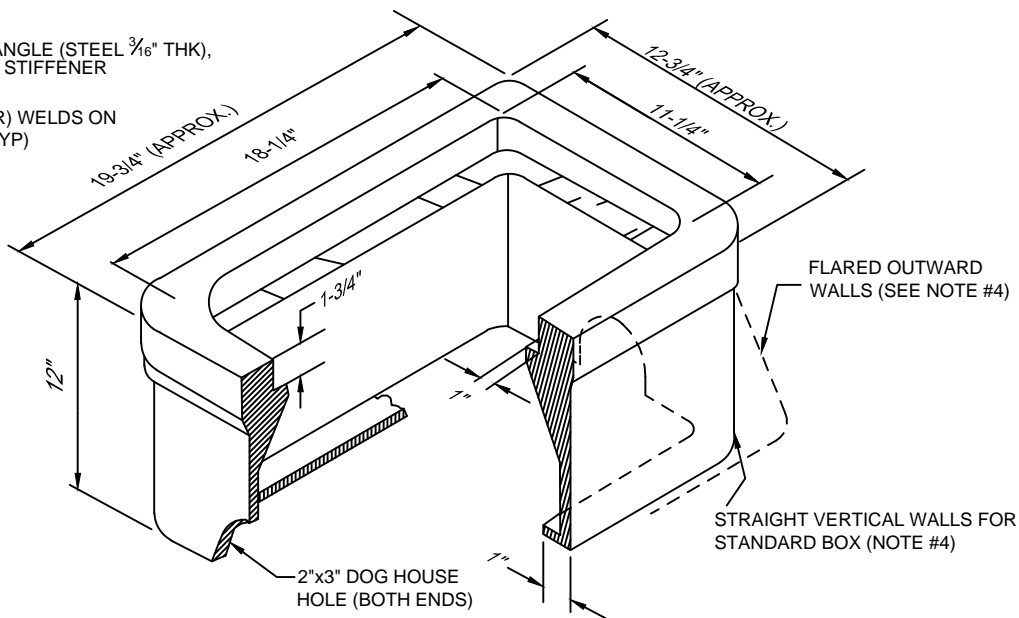

POLYMER BOX

NOTES:

1. THE STANDARD BOX (A-8 (ASTM C857) LOAD RATING WITH STRAIGHT VERTICAL WALLS) & TOP (A-8 (ASTM C857) RATING WITH 2 HOLES) SHALL BE MADE OF POLYMER CONCRETE. (SIMILAR TO OLD BROOKS SERIES 37 BOX). BOX WALLS SHALL BE FIBERGLASS. THE INSIDE LIP OF THE BOX SHALL BE RATED SAME AS THE BOX. THE ONE HOLE LIDS ARE FOR SPECIAL ORDERS ONLY AND REQUIRE JEA'S APPROVAL PRIOR TO USE.
2. ALL SIZES SHOWN ARE IN INCHES AND ARE APPROXIMATE SIZES.
3. POLYMER BOX APPROXIMATE WEIGHT 25lbs. POLYMER TOP APPROXIMATE WEIGHT 20lbs. SEE CONSTRUCTION DETAILS W-3A (TWO HOLE) AND W-3B (ONE HOLE) FOR MANUFACTURING DETAILS FOR COVERS.
4. UNLESS APPROVED OTHERWISE IN WRITING BY JEA, ALL METER BOXES SHALL BE LOCATED IN NON-TRAFFIC AREAS (NOT IN THE ROADWAY, DRIVEWAYS OR SIDEWALKS). IF AN EXCEPTION TO THIS RULE IS APPROVED BY JEA, THEN THE FOLLOWING SHALL BE PROVIDED:
 - A) UNDER NO CIRCUMSTANCE SHALL A METER BOX BE LOCATED IN A COMMERCIAL TRAFFIC AREA.
 - B) IF AN EXCEPTION IS APPROVED IN WRITING THE METER BOX LOCATED IN A SIDEWALK OR RESIDENTIAL DRIVEWAY SHALL INCLUDE A POLYMER BOX WITH FLARED OUTWARD WALLS (NOT STRAIGHT WALLS) AND A POLYMER TOP. BOX AND TOP SHALL COMPLY WITH A-8 (ASTM C857), LOAD RATING.
 - C) METAL TOPS MAY BE UTILIZED IF SPECIFICALLY APPROVED BY JEA MANAGER OR JEA METER O&M STAFF.

**WATER METER BOX & COVER FOR
1" AND SMALLER METERS**

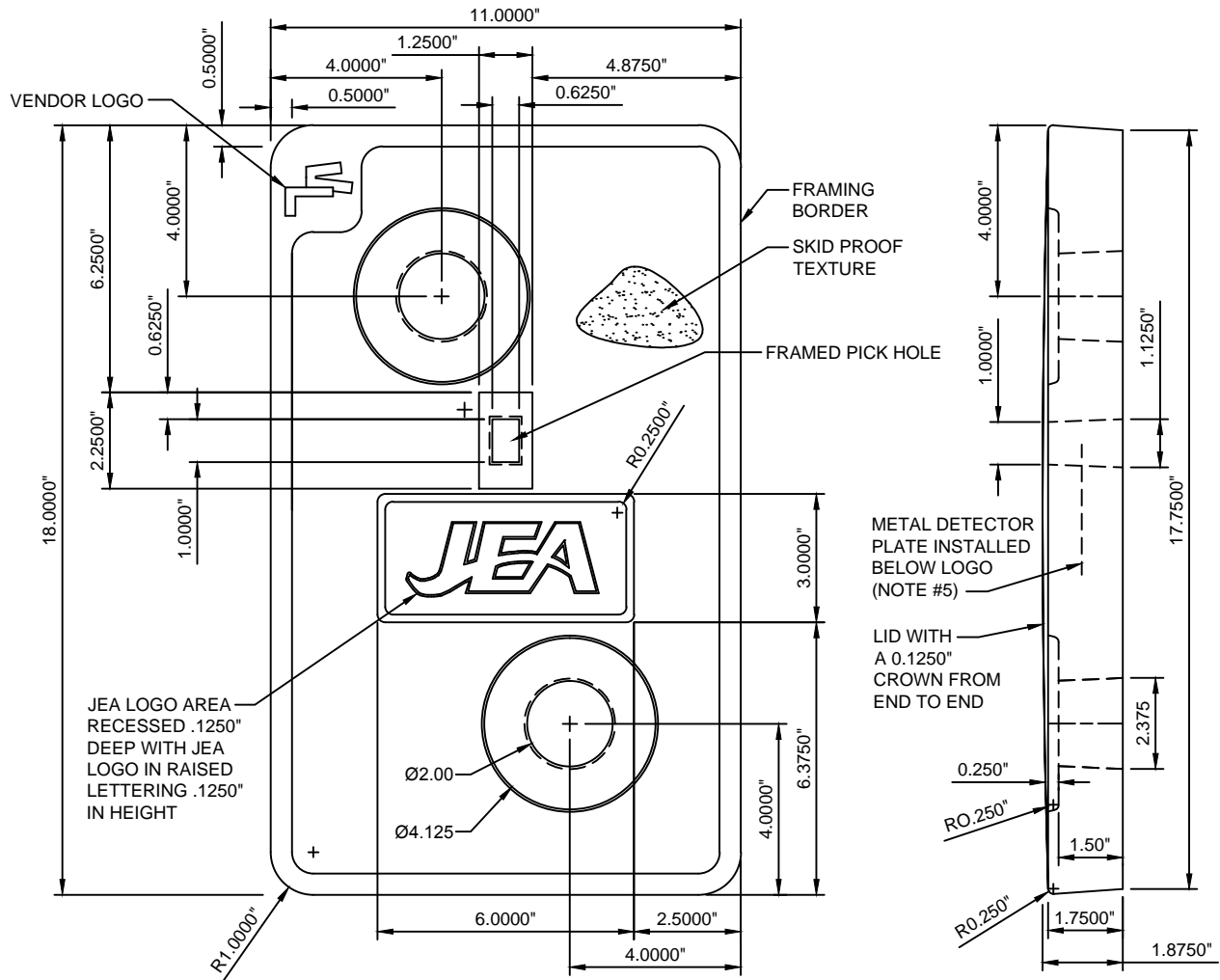

TOP VIEW

SIDE PROFILE

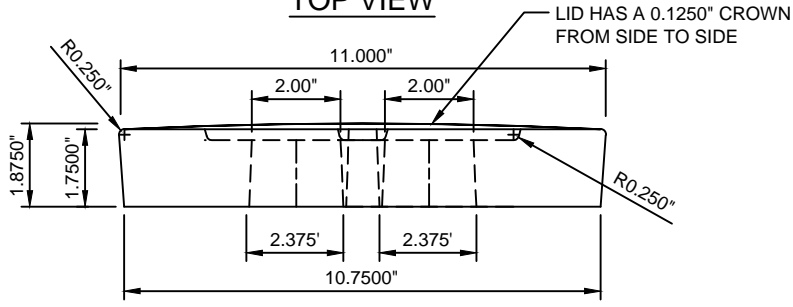

END PROFILE

NOTES:

1. ALL DIMENSIONS ARE IN INCHES.
2. COLOR SHALL BE OFF-WHITE, NON-POROUS, SAND TEXTURED SATIN FINISH.
3. ALL TOPS SHALL MEET A-8 (ASTM C857) LOAD RATING.
4. THE LID SHALL BE CERTIFIED BY CELLNET TECHNOLOGY INC AND SENSUS METERING SYSTEMS TO BE RF COMPATIBLE WITH THE SENSUS MTU.
5. METAL DETECTOR PLATE SHALL BE DETECTABLE BY JEA MAGNETIC LOCATE EQUIPMENT.

**WATER METER BOX POLYMER COVER
MODEL No. 37 - TWO HOLE**

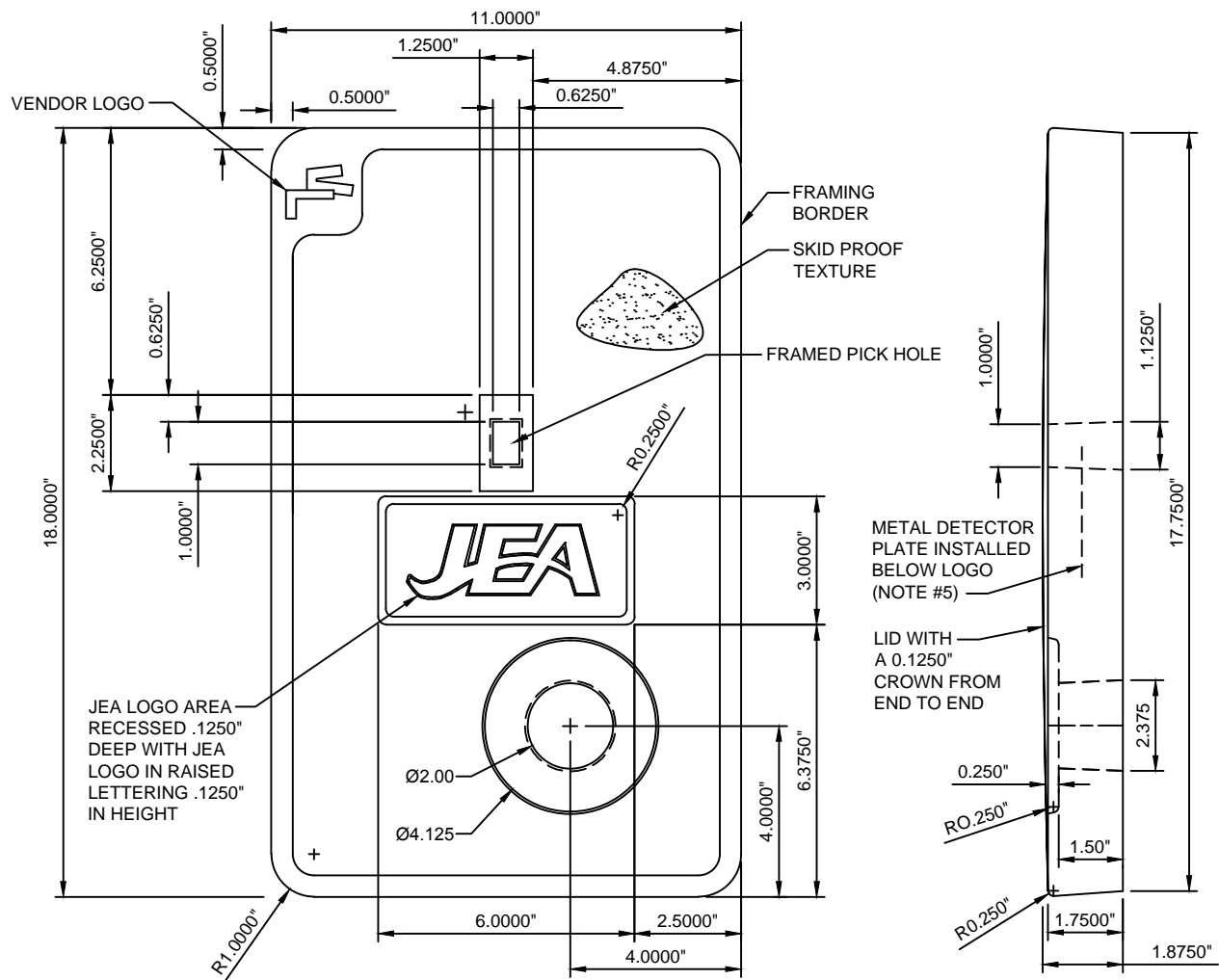

TOP VIEW

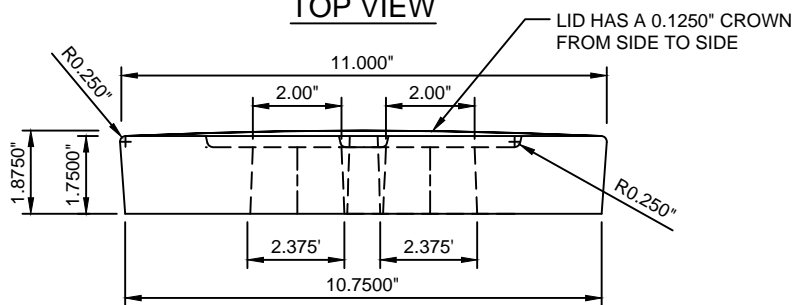

SIDE PROFILE

END PROFILE

NOTES:

1. ALL DIMENSIONS ARE IN INCHES.
2. COLOR SHALL BE OFF-WHITE, NON-POROUS, SAND TEXTURED SATIN FINISH.
3. ALL TOPS SHALL MEET A-8 (ASTM C857) LOAD RATING.
4. THE LID SHALL BE CERTIFIED BY CELLNET TECHNOLOGY INC AND SENSUS METERING SYSTEMS TO BE RF COMPATIBLE WITH THE SENSUS MTU.
5. METAL DETECTOR PLATE SHALL BE DETECTABLE BY JEA MAGNETIC LOCATE EQUIPMENT.
6. THE ONE HOLE LIDS ARE FOR SPECIAL ORDERS ONLY AND REQUIRE JEA'S APPROVAL PRIOR TO USE.

WATER METER BOX POLYMER COVER MODEL No. 37 - ONE HOLE

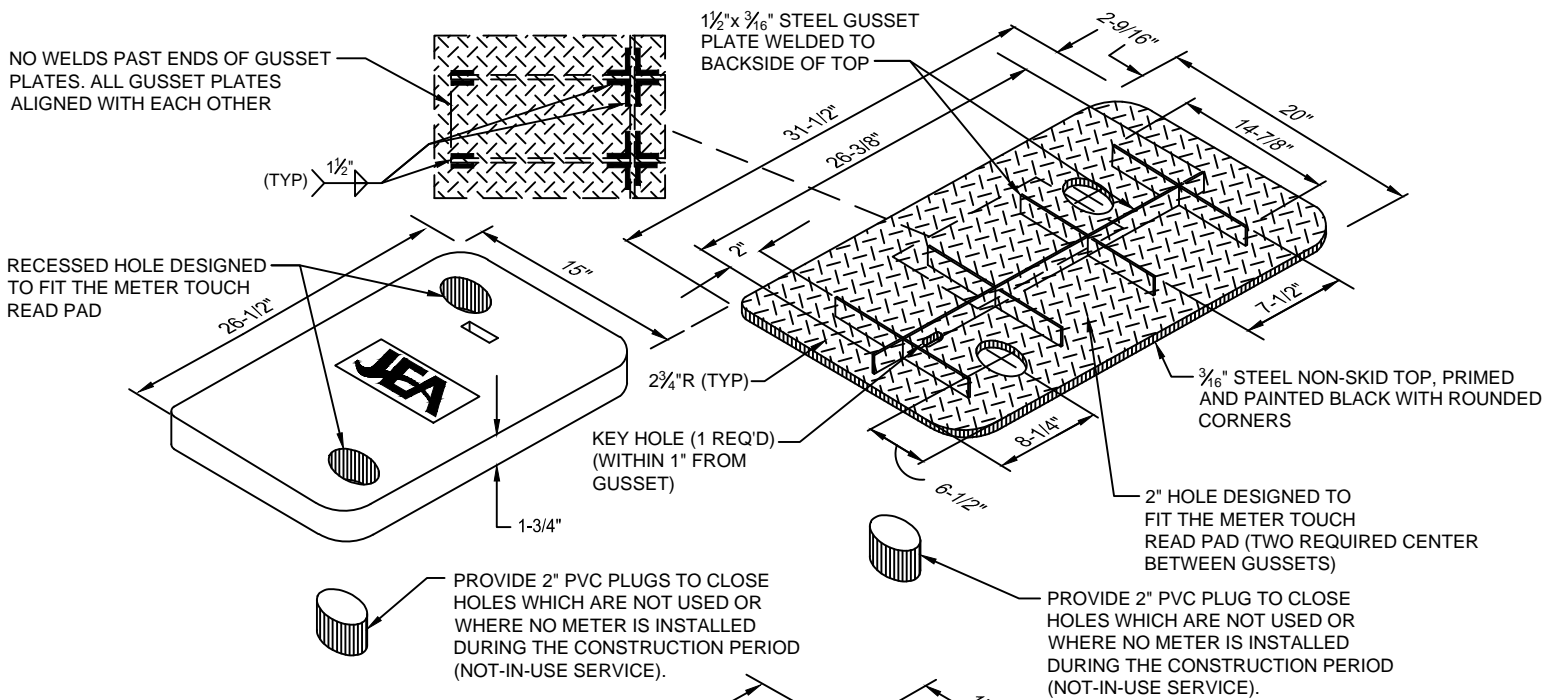

POLYMER TOP
(SEE NOTE #1)

METAL TOP
(SEE NOTE #4)

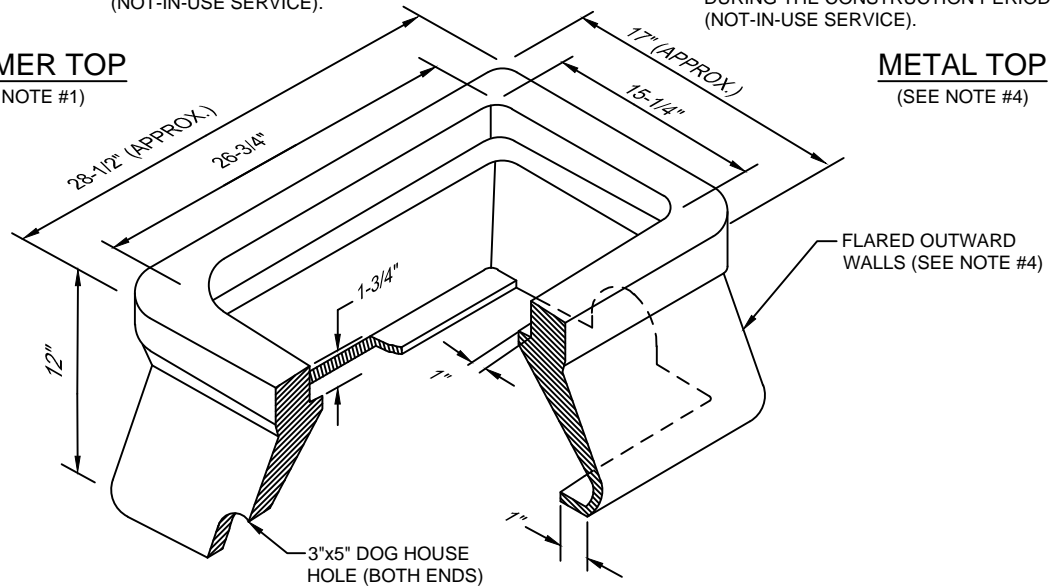

POLYMER BOX

NOTES:

1. THE STANDARD BOX (FLARED OUTWARD WALLS) & TOP (2 HOLE) SHALL BE MADE OF POLYMER CONCRETE. (SIMILAR TO OLD BROOKS SERIES 65). BOX WALLS SHALL BE FIBERGLASS. BOX, INCLUDING THE INSIDE LIP, AND TOP SHALL MEET A-8 (ATSM C857) LOAD RATING.
2. ALL SIZES SHOWN ARE IN INCHES AND ARE APPROXIMATE SIZES.
3. POLYMER BOX APPROXIMATE WEIGHT 50lbs. POLYMER TOP APPROXIMATE WEIGHT 50lbs. SEE CONSTRUCTION DETAIL W-4A FOR MANUFACTURING DETAIL FOR TWO HOLE COVER.
4. UNLESS APPROVED OTHERWISE IN WRITING BY JEA, ALL METER BOXES SHALL BE LOCATED IN NON-TRAFFIC AREAS (NOT IN THE ROADWAY, DRIVEWAYS OR SIDEWALKS).
5. METAL TOPS MAY BE UTILIZED IF SPECIFICALLY APPROVED BY A JEA MANAGER OR BY JEA METER O&M STAFF.

**WATER METER BOX & COVER FOR
1-1/2" AND 2" METERS**

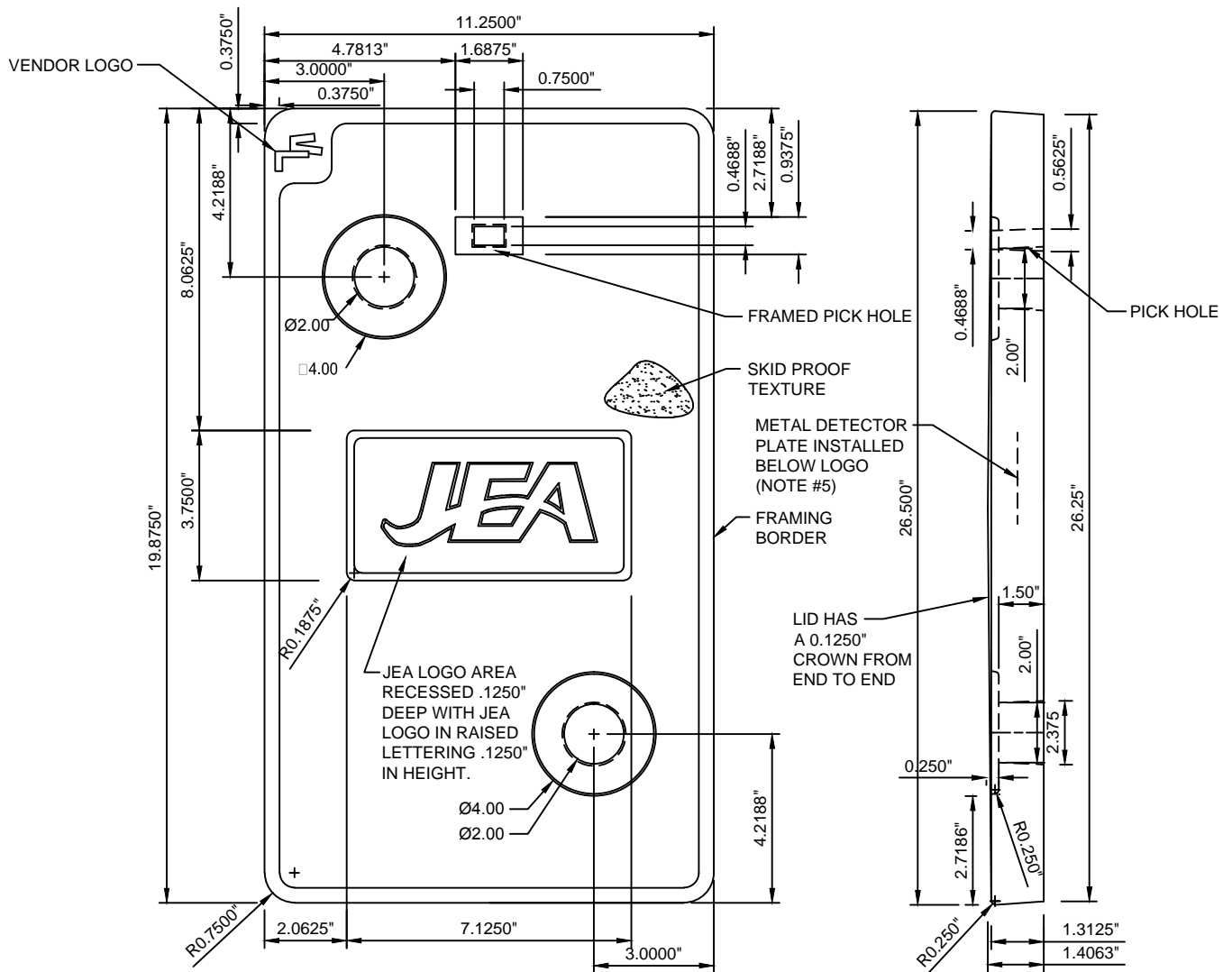

TOP VIEW

SIDE PROFILE

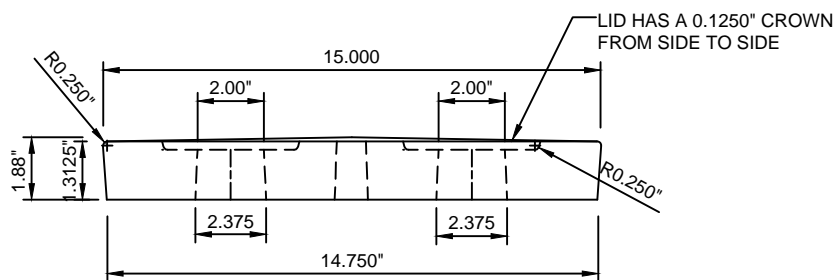

END PROFILE

NOTES:

1. ALL DIMENSIONS ARE IN INCHES.
2. COLOR SHALL BE OFF-WHITE, NON-POROUS, SAND TEXTURED SATIN FINISH.
3. ALL TOPS SHALL MEET A-8 (ASTM C857) LOAD RATING.
4. THE LID SHALL BE CERTIFIED BY CELLNET TECHNOLOGY INC AND SENSUS METERING SYSTEMS TO BE RF COMPATIBLE WITH THE SENSUS MTU.
5. METAL DETECTOR PLATE SHALL BE DETECTABLE BY JEA MAGNETIC LOCATE EQUIPMENT.

WATER METER BOX POLYMER CONCRETE COVER MODEL No. 65 - TWO HOLE

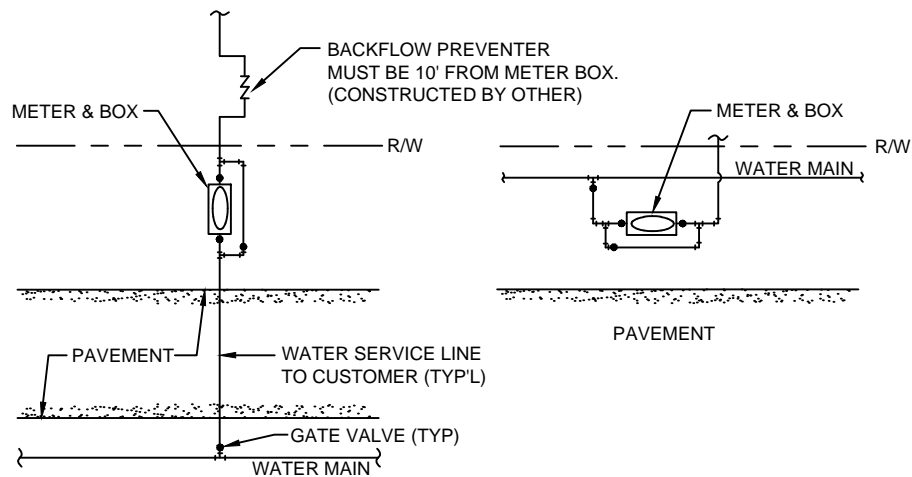
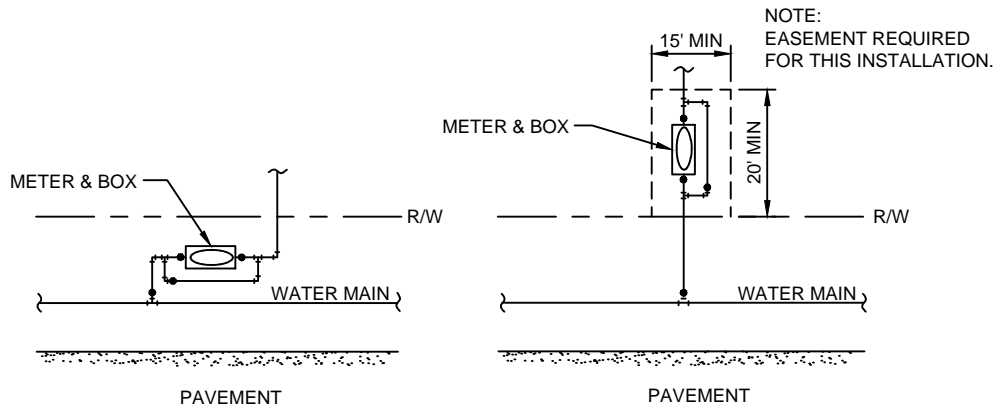

NOTES:

1. THE SKETCHES ABOVE ARE SUGGESTIONS FOR SOME TYPICAL LARGE METER (3" AND LARGE SIZE METER) INSTALLATIONS. ACTUAL INSTALLATIONS WILL VARY ACCORDING TO FIELD CONDITIONS ENCOUNTERED. FOR OTHER LOCATION LIMITATIONS SEE PLATE NOS. W-10 & W-11.
2. THE WATER METER BOX SHALL BE CO-POLYMER MATERIAL. IF THE BOX IS LOCATED IN A DRIVEWAY OR ROADWAY, THE BOX SHALL BE CONCRETE WITH HEAVY-DUTY ALL GALVANIZED (WITH REINFORCED GALV.) TOP. BOXES LOCATED IN DRIVEWAYS OR ROADWAYS MUST BE APPROVED BY JEA, PRIOR TO CONSTRUCTION.
3. FOR TYPICAL BOX INSTALLATION DETAILS SEE PLATE NO. W-6 THRU W-8.
4. FOR TYPICAL MANIFOLD INSTALLATION, SEE PLATE NO. W-9.

LARGE WATER METER INSTALLATIONS

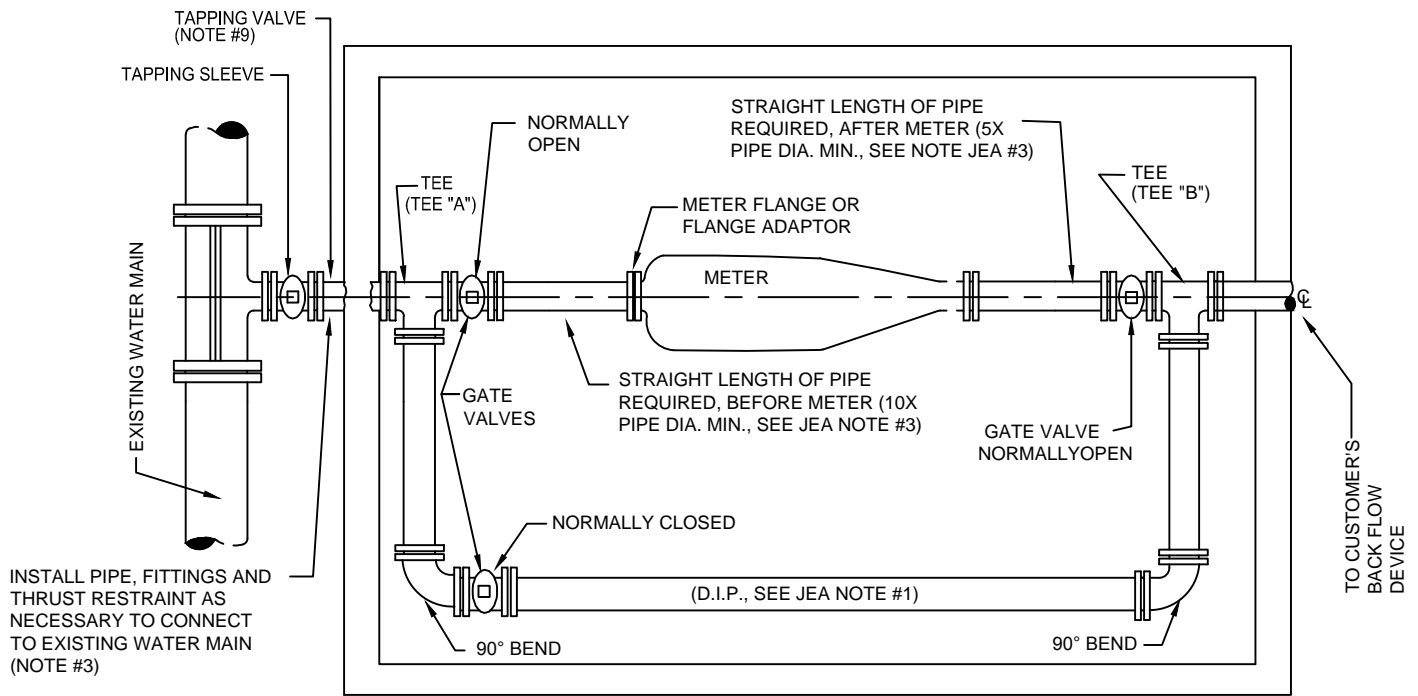

TO BE INSTALLED BY JEA (SEE NOTE #1)
 MIN. LAYING LENGTH REQUIRED
 3" & 4" METERS.....14'
 6" & 8" METERS.....20'
 10" METERS.....24'
 (D.I.P. REQUIRED, SEE JEA NOTES #1 & #2)

CONTRACTOR NOTES:

1. FOR "PRE-PAVE" INSTALLATIONS, THE CONTRACTOR SHALL CONSTRUCT TAP AND WATER MAIN PIPING (PVC OR D.I.P.) BETWEEN TAPPING VALVE AND R/W PROVIDING AN UN-INSTALLED (OPEN) PIPE SECTION WITH A "MINIMUM LAYING LENGTH" AS SHOWN ABOVE FOR THE METER BOX AND BY PASS PIPING. THE FINISHED GRADE AT THE PROPOSED METER VAULT SHALL BE FLAT. CONTRACTOR SHALL PROVIDE METER BOX. JEA WILL INSTALL METER BOX AND METER ASSEMBLY (INCLUDING METER, THREE (3) GATE VALVES AND ASSOCIATED DUCTILE IRON PIPE ALL THE SAME SIZE).
2. FOR "FULL-TAP" METER ASSEMBLY, JEA WILL PROVIDE AND INSTALL THE TAP, METER BOX AND ALL OF THE ABOVE PIPING WITHIN THE R/W.
3. FOR BOX DETAILS SEE PLATES W-7 AND W-8.
4. ALL POTABLE PIPE AND FITTINGS TO BE SAME SIZE AS METER. IF UTILIZING HDPE PIPE.
5. MECHANICAL RETAINER GLAND RESTRAINTS OR MEGA LUGS SHALL BE UTILIZED TO RESTRAIN ALL JOINTS. THE USE OF THRUST BLOCKS, TIE RODS AND/OR BELL/ROD RESTRAINTS SHALL ONLY BE USED IF SPECIFICALLY APPROVE BY JEA MANAGEMENT.
6. PIPE FROM TAP TO R/W LINE SHALL BE RESTRAINED.
7. MAXIMUM COVER OF LARGE WATER METERS SHALL BE 36" (FROM TOP OF PIPE TO GRADE).
8. LOCATING WIRING REQUIRED FROM EXISTING WATER MAIN TO METER BOX. SEE PLATE W-44.
9. FOR METERS LARGER THAN 10" SIZE, PLEASE CONTACT JEA METER SHOP FOR ADDITIONAL REQUIREMENTS.
10. EACH SERVICE (FIRE MAIN, POTABLE WATER, ETC.) SHALL INCLUDE A SEPARATE ISOLATION VALVE (TAPPING VALVE OR GATE VALVE, BELOW GROUND TYPE) LOCATED PRIOR TO TEE "A". ALSO, UN-METERED FIRE MAIN SERVICES SHALL INCLUDE A SEPARATE ISOLATION VALVE (TAPPING VALVE OR GATE VALVE, BELOW GROUND TYPE).
11. FOR TYPICAL MANIFOLD INSTALLATION, SEE PLATE NO. W-9.
12. SERVICE SIZE SHALL BE SAME AS THE METER SIZE.

JEA NOTES:

1. ALL POTABLE PIPING BETWEEN TEE FITTINGS (TEE "A" AND TEE "B") SHALL BE DR18 OR CLASS 150 D.I.P., INCLUDING BY-PASS PIPING.
2. ALL POTABLE VALVES AND FITTINGS TO BE DUCTILE IRON RESTRAINED JOINT.
3. MINIMUM LENGTH OF TEN (10) PIPE DIAMETERS OF STRAIGHT PIPE TO BE INSTALLED ON INLET SIDE OF METER AND FIVE (5) PIPE DIAMETERS OF STRAIGHT PIPE TO BE INSTALLED ON OUTLET SIDE OF METER.
4. ALL METER INSTALLATIONS REQUIRE A TEST TEE TO BE INSTALLED BETWEEN THE METER AND VALVE ON CONSUMER SIDE OF METER.

WATER METER INSTALLATION DETAILS

3" - 20" METERS

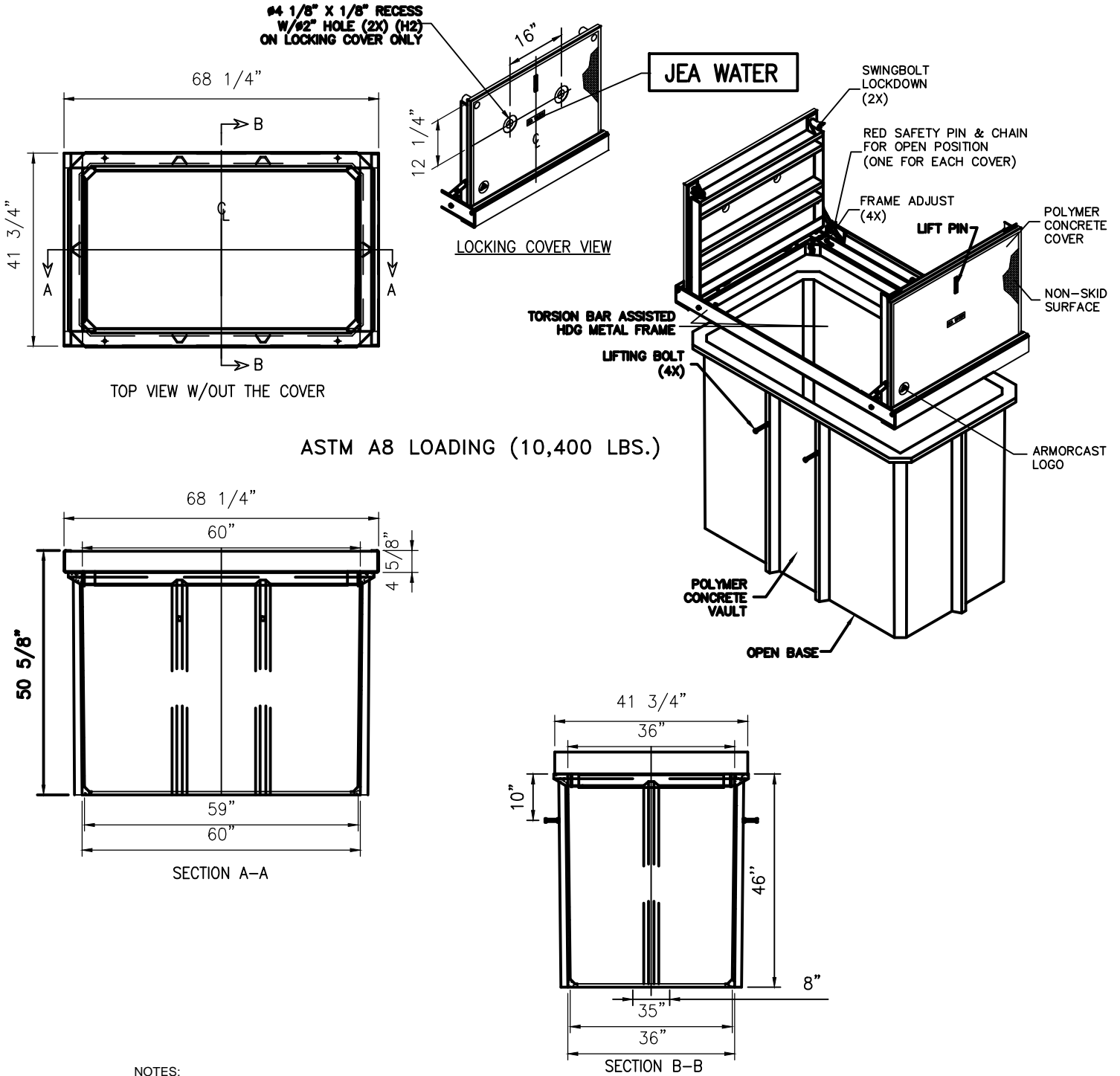

NOTES:

1. THE DIMENSIONS SHOWN ARE FOR A STANDARD 36" WIDE BY 60" LONG BY 48" DEEP BOX. DIMENSIONS VARY ACCORDING TO METER SIZE & TYPE. SEE PLATE W-8. ALL DIMENSIONS ARE SHOWN IN INCHES.
2. CONCRETE OR ASPHALT SLOPE: 1/8 IN./FT.
3. GRADE TO SLOPE AWAY FROM METER BOX.
4. DO NOT INSTALL METER BOX IN AREA SUBJECTED TO FLOODING.
5. LOCATING WIRING REQUIRED. SEE DETAIL W-44.
6. THE LARGE BOXES REQUIRE TWO 2" RECESSED HOLES TO FIT ANTENNA.
7. A 4" THICK CONCRETE BOTTOM SHALL BE CONSTRUCTED DURING THE BOX INSTALLATION.

36" x 60" x 48" CO-POLYMER WATER METER BOX 3" & 4" METERS

APPROX. WT. = 1425 LBS.

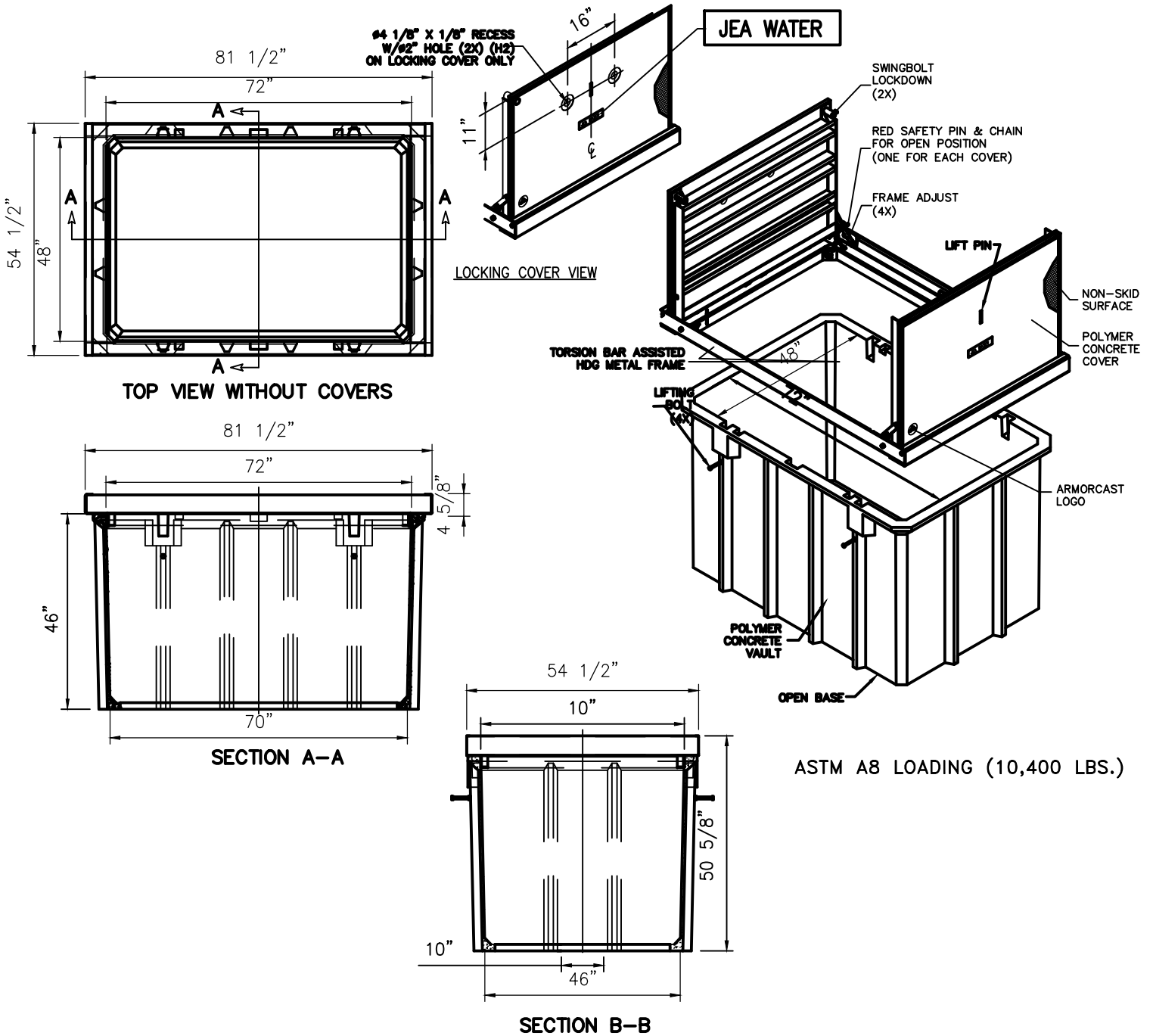

NOTES:

1. THE DIMENSIONS SHOWN ARE FOR A STANDARD 48" WIDE BY 72" LONG BY 48" DEEP BOX. DIMENSIONS VARY ACCORDING TO METER SIZE & TYPE. SEE PLATE W-8. ALL DIMENSIONS ARE SHOWN IN INCHES.
2. CONCRETE OR ASPHALT SLOPE: 1/8 IN./FT.
3. GRADE TO SLOPE AWAY FROM METER BOX.
4. DO NOT INSTALL METER BOX IN AREA SUBJECTED TO FLOODING.
5. LOCATING WIRING REQUIRED. SEE DETAIL W-44.
6. THE LARGE BOXES REQUIRE TWO 2" RECESSED HOLES TO FIT ANTENNA.
7. A 4" THICK CONCRETE BOTTOM SHALL BE CONSTRUCTED DURING THE BOX INSTALLATION.

48" x 72" x 48" CO-POLYMER WATER METER BOX 4" & 6" METERS

APPROX. WT. = 1990 LBS.

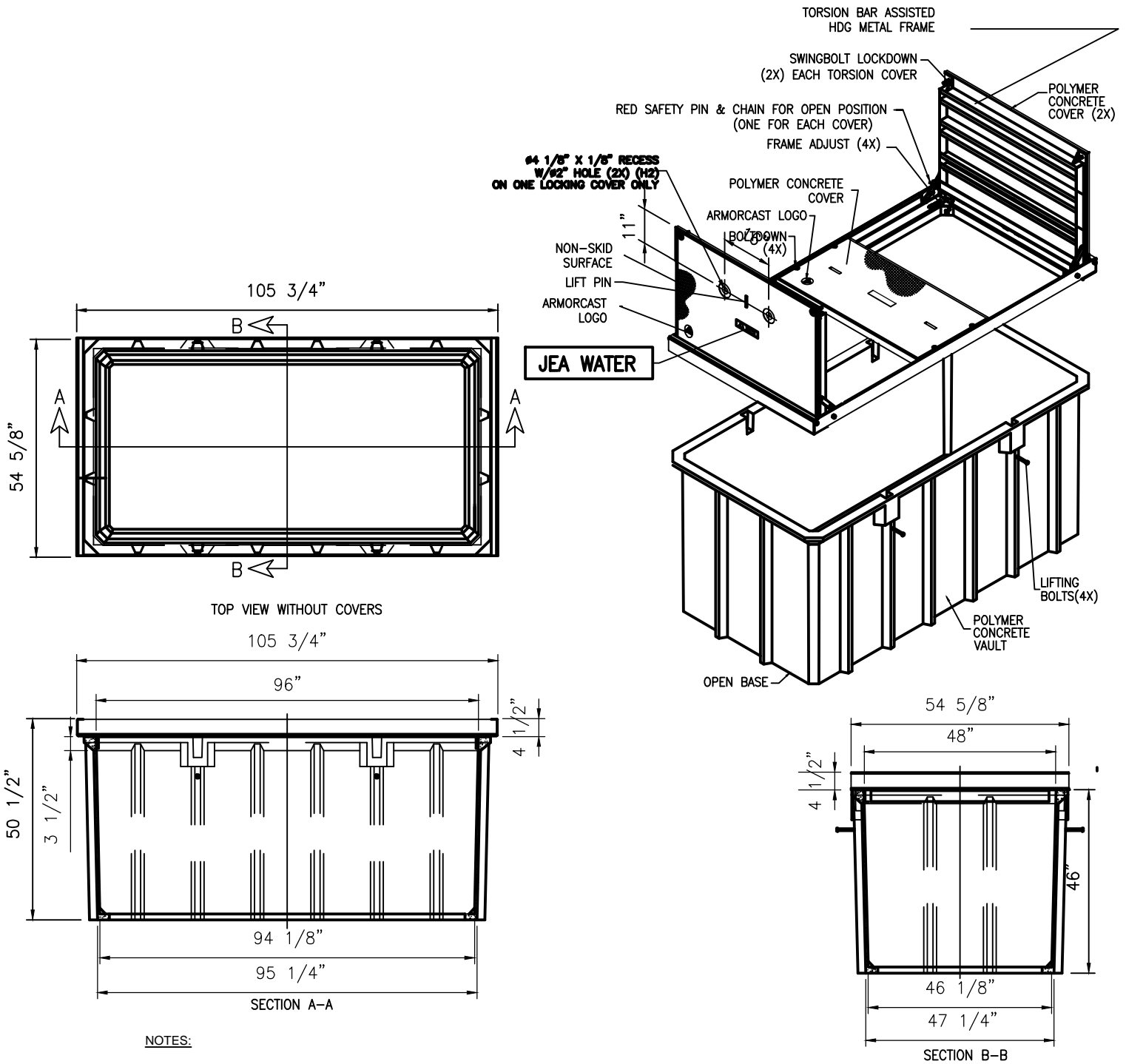

NOTES:

1. THE DIMENSIONS SHOWN ARE FOR A STANDARD 48" WIDE BY 96" LONG BY 48" DEEP BOX. DIMENSIONS VARY ACCORDING TO METER SIZE & TYPE. SEE PLATE W-8. ALL DIMENSIONS ARE SHOWN IN INCHES.
2. CONCRETE OR ASPHALT SLOPE: 1/8 IN./FT.
3. GRADE TO SLOPE AWAY FROM METER BOX.
4. DO NOT INSTALL METER BOX IN AREA SUBJECTED TO FLOODING.
5. LOCATING WIRING REQUIRED. SEE DETAIL W-44.
6. THE LARGE BOXES REQUIRE TWO 2" RECESSED HOLES TO FIT ANTENNA.
7. A 4" THICK CONCRETE BOTTOM SHALL BE CONSTRUCTED DURING THE BOX INSTALLATION.

48" x 96" x 48" CO-POLYMER WATER METER BOX 6" - 20" METERS

WATER METER BOX DIMENSIONS (3" - 20" METERS)

Meter Description		Polymer Concrete Box Non-Traffic Rated (Note 1)
Type	SIZE	Width x Length x Depth (O.D.)
C-2 or T-2 Omni Style	3"	36" x 60" x 48"
	4"	36" x 60" x 48"
	6"	48" x 72" x 48"
Fire Meter	4"	48" x 72" x 48"
	6"	48" x 96" x 48"
	8"	48" x 96" x 48"
	10"	48" x 96" x 48"
* Includes 6" Thick Bottom		

NOTES:

1. POLYMER CONCRETE BOXES SHALL ONLY BE PROVIDED IN NON-TRAFFIC (INCLUDING NOT IN DRIVEWAYS) LOCATIONS. FRP/ POLYMER CONCRETE METER BOX & COVER (BY ARMOURCAST PRODUCTS COMPANY): BOX AND THE EXTENSION IF REQUIRED, SHALL BE MANUFACTURED USING FIBERGLASS REINFORCED MATERIALS AND POLYMER CONCRETE. THE BODY OF THE BOX WITH NO BOTTOM SHALL BE MANUFACTURED USING FIBERGLASS REINFORCED MATERIALS, COMPRISED FROM POLYESTER RESINS AND FIBERGLASS MATTING. THE TOP COLLAR AND COVER SHALL BE MANUFACTURED FROM POURED POLYMER CONCRETE AND SHALL BE CONCRETE GREY COLOR. DURING THE MANUFACTURING PROCESS AND WHILE THE POLYMER CONCRETE IS IN A SOFTENED STATE, THE BODY SHALL BE MARRIED TO THE COLLAR BY INSERTING IT INTO THE COLLAR'S FORM. THE BOX AND COVER SHALL HAVE A LOAD RATING OF A8 (ASTM C857). THE BOX SHALL CONFORM TO THESE DESIGN FUNCTIONS AND DIMENSIONAL REQUIREMENTS AND INCLUDE LIFTING STUDS. BOX EXTENSIONS SHALL BE PROVIDED FOR ALL DEEP INSTALLATIONS. THE BOX SHALL BE A 2-PIECE ASSEMBLY INCLUDING MOLDED/RAISED JEA LOGO (LOGO ON BOTH PIECES). RECESSED HOLES (APPROXIMATELY 2" DIAMETER) DESIGNED TO FIT A SCHLUMBERGER ANTENNA USED WITH A METER INTERFACE UNIT (MIU). TWO COVER HOLD-DOWN BOLTS (1/2 - 13NC S.S. PENTAHEAD BOLTS). TORSION ASSISTED COMPONENTS AND TEXTURED NON-SKID SURFACE. A 2" PVC PLUG SHALL BE PROVIDED FOR EACH 2"-HOLE WHICH CAN BE COMPRESSED (TIGHT FIT) INTO THE 2" HOLE FOR TEMPORARY CLOSURE OF THE HOLE.
2. FOR WATER METERS LARGER THAN 6" OR FIRE MAINS LARGER THAN 10" SIZE, PLEASE CONTACT JEA METER SHOP FOR CONSTRUCTION REQUIREMENTS.

WATER METER BOX DIMENSIONS 3" - 20" METERS

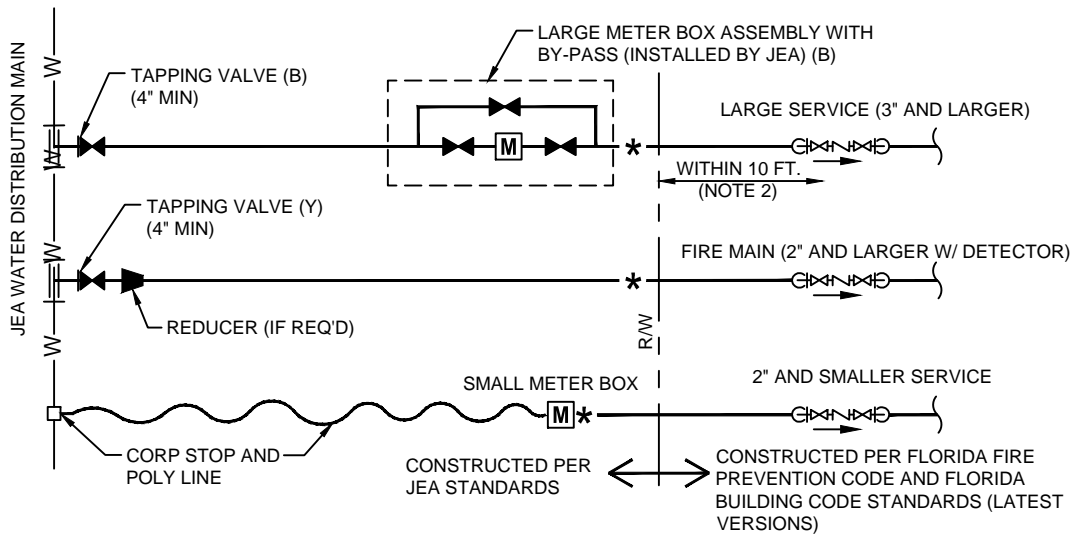

CASE I
SEPARATE INDIVIDUAL SERVICE ARRANGEMENT

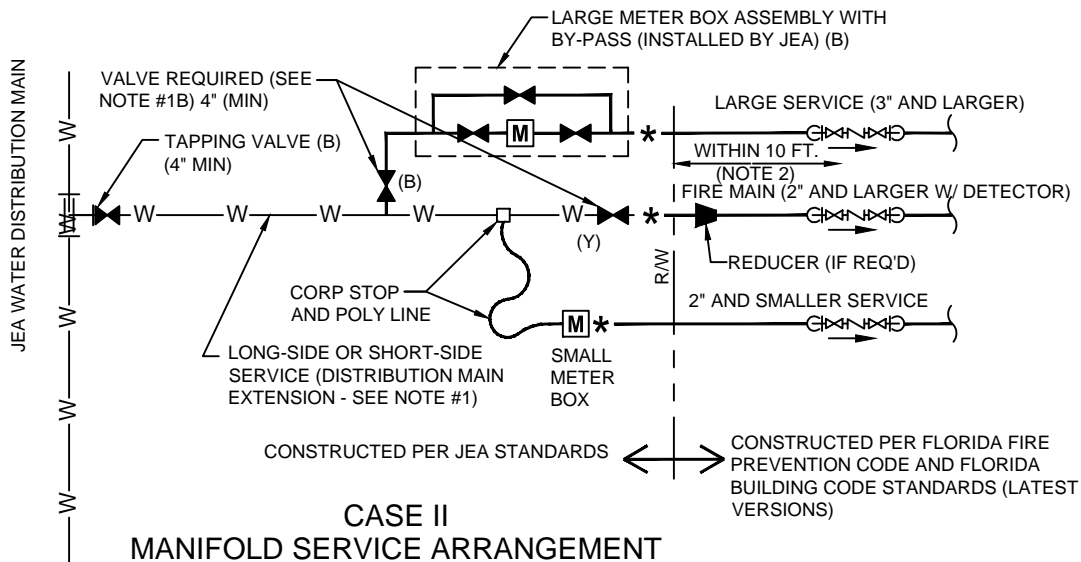

CASE II
MANIFOLD SERVICE ARRANGEMENT

KEY

- GATE VALVE
- (B) VALVE COVER PAINT COLOR
(B) = BLUE (Y) = YELLOW
- * JEA POINT OF SERVICE
- BACKFLOW PREVENTER
(NOTE #2)
- W— JEA WATER DISTRIBUTION MAIN
- JEA METER

NOTES:

1. SHOULD AN INSTALLATION INCLUDE MULTIPLE WATER SERVICES FOR THE SAME CUSTOMER (i.e. DOMESTIC, IRRIGATION, FIRE) AND ONE OR MORE OF THOSE SERVICES ARE 3 INCH OR LARGER, A MANIFOLD ARRANGEMENT (SEE CASE II ABOVE) IS ACCEPTABLE PROVIDED:
 - A. THE PROJECT DESIGN ENGINEER (FLORIDA PROFESSIONAL ENGINEER) PROVIDES ACCEPTABLE HYDRAULIC CALCULATION (ENGINEERED, SIGNED AND SEALED) WHICH MEETS THE MOST HYDRAULICALLY DEMANDING CASE.
 - B. TO MEET JEA AND LOCAL FIRE CODE REQUIREMENTS, A SEPARATE ISOLATION VALVE (BELOW GROUND TYPE GATE VALVE OR CORP STOP) SHALL BE PROVIDED FOR EACH SERVICE ON A MANIFOLD ARRANGEMENT.
 - C. THE SPECIFIC PROPOSED WATER SERVICE ARRANGEMENT IS IN ACCORDANCE WITH JEA STANDARDS AND IS REVIEWED AND APPROVED BY JEA.
2. BACKFLOW PREVENTER (BFP) - THE ABOVE GROUND VALVE SHALL MEET JEA'S CROSS-CONNECTION CONTROL PROGRAM. THIS JEA APPROVED VALVE SHALL BE INSTALLED WITHIN TEN (10) FEET OF RIGHT-OF-WAY LINE OR JEA EASEMENT UNLESS APPROVED OTHERWISE BY JEA. ALL BFPs INSTALLED ON A FIRE MAIN SHALL INCLUDE A DETECTOR.

WATER SERVICE MANIFOLD ARRANGEMENT

HORIZONTAL & VERTICAL SEPARATION REQUIREMENTS

PROPOSED UTILITY

CONFLICTING UTILITY	POTABLE WATER			WASTEWATER GRAVITY AND FORCEMAIN			RECLAIMED WATER			VACUUM SEWERS		
	HORIZ.	VERT.	JOINT SPACING*	HORIZ.	VERT.	JOINT SPACING*	HORIZ.	VERT.	JOINT SPACING*	HORIZ.	VERT.	JOINT SPACING*
POTABLE WATER	3' NOTE 1	12"	3' NOTE 2	6' to 10'	12" NOTE 5	6' NOTE 2	3'	12"	6' NOTE 2	3' to 10'	12"	3' NOTE 2
RECLAIMED WATER	3'	12"	6' NOTE 2	3' NOTE 1	12"	3' NOTE 2	3'	12"	6' NOTE 2	3' NOTE 1	12"	3' NOTE 2
WASTEWATER (GRAVITY AND FORCE MAIN)	6' to 10'	12"	6' NOTE 2	3' NOTE 1	12"	6"	3' NOTE 1	12"	3' NOTE 2	3' NOTE 1	12"	3' NOTE 2
VACUUM SEWERS	3' to 10'	12"	3' NOTE 2	3' NOTE 1	12"	6"	3' NOTE 1	12"	3' NOTE 2	3' NOTE 1	12"	3' NOTE 2
RIGHT OF WAYS	3' NOTE 1	N/A	N/A	3' NOTE 1	N/A	N/A	3' NOTE 1	N/A	N/A	3' NOTE 1	N/A	N/A
PERMANENT STRUCTURES (SIGNS, TREES, POLES, ETC.)	3' NOTE 1	N/A	N/A	3' NOTE 1	N/A	N/A	3' NOTE 1	N/A	N/A	3' NOTE 1	N/A	N/A
STORM SEWERS	3' NOTE 1	12"	3' NOTE 2	3' NOTE 1	12"	3' NOTE 2	3' NOTE 1	12"	3' NOTE 2	3' NOTE 1	12"	3' NOTE 2
GAS	3' NOTE 1	12"	3' NOTE 2	3' NOTE 1	12"	3' NOTE 2	3' NOTE 1	12"	3' NOTE 2	3' NOTE 1	12"	3' NOTE 2
ALL OTHER UTILITIES	3' NOTE 1	12"	3' NOTE 2	3' NOTE 1	12"	3' NOTE 2	3' NOTE 1	12"	3' NOTE 2	3' NOTE 1	12"	3' NOTE 2

NOTES:

1. THIS SEPARATION REQUIREMENT IS TO PROVIDE ACCESSIBILITY FOR CONSTRUCTION AND MAINTENANCE. THREE FEET OF HORIZONTAL SEPARATION IS THE MINIMUM FOR PIPES WITH THREE FEET OF COVER. FOR PIPES INSTALLED AT GREATER DEPTH, PROVIDE AN ADDITIONAL FOOT OF SEPARATION FOR EACH ADDITIONAL FOOT OF DEPTH.
2. THE MINIMUM JOINT SPACING REQUIRED FROM CROSSING FROM OTHER UTILITIES WHILE STILL MAINTAINING MINIMUM VERTICAL SEPARATION.
3. DISTANCES GIVEN ARE FROM OUTSIDE OF PIPE TO OUTSIDE OF PIPE.
4. NO WATER PIPE SHALL PASS THROUGH OR COME INTO CONTACT WITH ANY PART OF SANITARY OR STORM WATER MANHOLE OR STRUCTURES.
5. WATER MAIN SHOULD CROSS ABOVE OTHER PIPES WHENEVER POSSIBLE. WHEN WATER MAIN MUST BE BELOW OTHER UTILITY PIPING, THE MINIMUM SEPARATION SHALL BE 12 INCHES.
6. REFER TO SECTION-350, PARAGRAPH III.4.

SEPARATION REQUIREMENTS FOR WATER, WASTEWATER AND RECLAIMED WATER MAINS

JANUARY 2018

PLATE W-10

WATER MAIN AND NON-WATER MAIN SEPARATION REQUIREMENTS - NOTES

1. IT IS REQUIRED THAT "WATER MAINS" BE INSTALLED, CLEANED, DISINFECTED AND HAVE A SATISFACTORY BACTERIOLOGICAL SURVEY PERFORMED IN ACCORDANCE WITH THE LATEST APPLICABLE AWWA STANDARDS, CHAPTER 62-555, F.A.C. AND LATEST JEA WATER AND SEWER STANDARDS. FOR THE PURPOSE OF THIS SECTION, THE PHRASE "WATER MAINS" SHALL MEAN MAINS, INCLUDING TREATMENT PLANT PROCESS PIPING, CONVEYING EITHER RAW, PARTIALLY TREATED, OR FINISHED DRINKING WATER; FIRE HYDRANT LEADS; AND SERVICE LINES THAT HAVE AN INSIDE DIAMETER OF THREE (3) INCHES OR GREATER. IN ADDITION, THE PHRASE "RECLAIMED WATER" REFERS TO THE WATER REGULATED UNDER PART III OF CHAPTER 62-610, F.A.C.
2. NEW OR RELOCATED, UNDERGROUND WATER MAINS SHALL BE LAID TO PROVIDE A HORIZONTAL DISTANCE OF AT LEAST THREE (3) FEET BETWEEN THE OUTSIDE OF THE WATER MAIN AND THE OUTSIDE OF ANY EXISTING OR PROPOSED STORM SEWER, STORMWATER FORCE MAIN, OR PIPELINE CONVEYING RECLAIMED WATER.
3. NEW OR RELOCATED, UNDERGROUND WATER MAINS SHALL BE LAID TO PROVIDE A HORIZONTAL DISTANCE OF AT LEAST SIX (6) FEET, AND PREFERABLY TEN (10) FEET, BETWEEN THE OUTSIDE OF THE WATER MAIN AND THE OUTSIDE OF ANY EXISTING OR PROPOSED GRAVITY OR PRESSURE-TYPE SANITARY SEWER, WASTEWATER FORCE MAIN, OR PIPELINE CONVEYING RECLAIMED WATER. THE MINIMUM HORIZONTAL SEPARATION DISTANCE BETWEEN WATER MAINS AND GRAVITY-TYPE SANITARY SEWERS MAY BE REDUCED TO THREE (3) FEET WHERE THE BOTTOM OF THE WATER MAIN IS LAID AT LEAST SIX (6) INCHES ABOVE THE TOP OF THE SEWER (SPECIAL CASE).
4. NEW OR RELOCATED, UNDERGROUND WATER MAINS CROSSING ANY EXISTING OR PROPOSED GRAVITY OR VACUUM-TYPE SANITARY SEWER OR STORM SEWER SHALL BE LAID SO THE OUTSIDE OF THE WATER MAIN IS AT LEAST SIX (6) INCHES, AND PREFERABLE TWELVE (12) INCHES, ABOVE OR AT LEAST TWELVE (12) INCHES BELOW THE OUTSIDE OF THE OTHER PIPELINE. HOWEVER, IT IS PREFERABLE TO LAY THE WATER MAIN ABOVE THE OTHER PIPELINE.
5. NEW OR RELOCATED, UNDERGROUND WATER MAINS CROSSING ANY EXISTING OR PROPOSED PRESSURE-TYPE SANITARY SEWER, WASTEWATER OR STORMWATER FORCE MAIN, OR PIPELINE CONVEYING RECLAIMED WATER SHALL BE LAID SO THE OUTSIDE OF THE WATER MAIN IS AT LEAST TWELVE (12) INCHES ABOVE OR BELOW THE OUTSIDE OF THE OTHER PIPELINE. HOWEVER, IT IS PREFERABLE TO LAY THE WATER MAIN ABOVE THE OTHER PIPELINE.
6. AT THE UTILITY CROSSINGS DESCRIBED IN NOTES 4 AND 5 ABOVE, ONE FULL LENGTH OF WATER MAIN PIPE SHALL BE CENTERED ABOVE OR BELOW THE OTHER PIPELINE SO THE WATER MAIN JOINTS WILL BE AS FAR AS POSSIBLE FROM THE OTHER PIPELINE. ALTERNATIVELY, AT SUCH CROSSINGS, THE PIPES SHALL BE ARRANGED SO THAT ALL WATER MAIN JOINTS ARE AT LEAST THREE (3) FEET FROM ALL JOINTS IN VACUUM-TYPE SANITARY SEWERS, STORM SEWERS, STORMWATER FORCE MAINS, OR PIPELINES CONVEYING RECLAIMED WATER, AND AT LEAST SIX (6) FEET FROM ALL JOINTS IN GRAVITY OR PRESSURE-TYPE SANITARY SEWERS, WASTEWATER FORCE MAINS, OR PIPELINE CONVEYING RECLAIMED WATER.
7. NEW OR RELOCATED FIRE HYDRANTS SHALL BE LOCATED SO THAT THE HYDRANTS ARE AT LEAST THREE (3) FEET FROM ANY EXISTING OR PROPOSED STORM SEWER, STORMWATER FORCE MAIN, OR PIPELINE CONVEYING RECLAIMED WATER; AT LEAST THREE (3) FEET, AND PREFERABLY TEN (10) FEET, FROM ANY EXISTING OR PROPOSED VACUUM-TYPE SANITARY SEWER; AT LEAST SIX (6) FEET, AND PREFERABLY TEN (10) FEET, FROM ANY EXISTING OR PROPOSED GRAVITY OR PRESSURE-TYPE SANITARY SEWER OR WASTEWATER FORCE MAIN.
8. WHERE AN UNDERGROUND WATER MAIN IS BEING LAID LESS THAN THE REQUIRED MINIMUM HORIZONTAL DISTANCE FROM ANOTHER PIPELINE AND WHERE AN UNDERGROUND WATER MAIN IS CROSSING ANOTHER PIPELINE AND JOINTS IN THE WATER MAIN ARE BEING LOCATED LESS THAN THE REQUIRED MINIMUM DISTANCE FROM JOINTS IN THE OTHER PIPELINE, THE CONTRACTOR SHALL CONSULT THE DESIGN ENGINEER TO OBTAIN APPROVAL OF ANY ALTERNATIVE CONSTRUCTION METHODS, PRIOR TO CONSTRUCTION.

NOTES ON UTILITY SEPARATION REQUIREMENTS

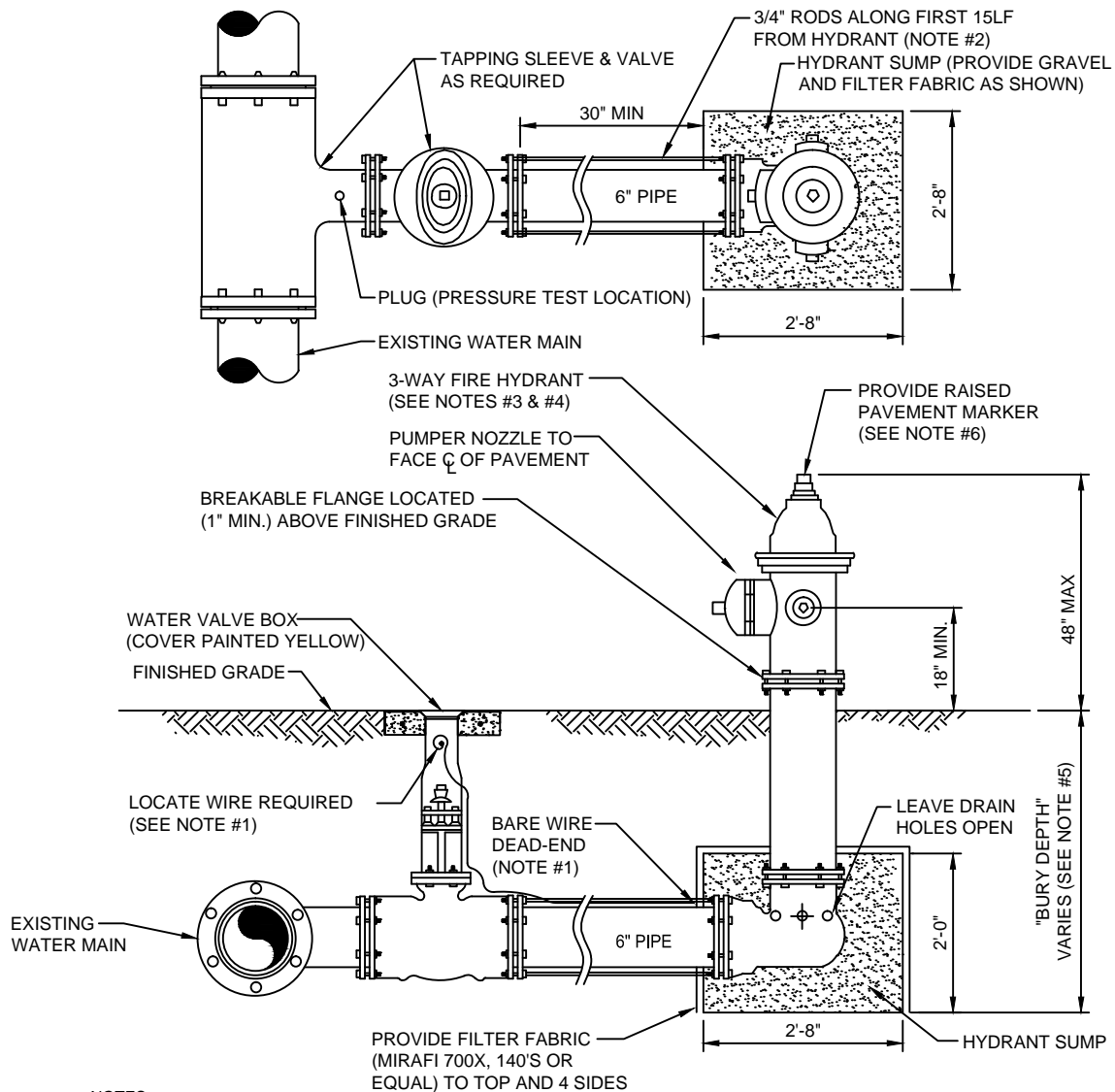

NOTES:

1. LOCATE WIRE SHALL BE ROUTED FROM THE VALVE TO THE HYDRANT AS SHOWN ABOVE. THE END OF THE WIRE SHALL BE SECURED TO THE PIPE MAIN. SEE SECTION 350, LOCATE WIRE INSTALLATION PARAGRAPH.
2. FIRE HYDRANTS SHALL BE INSTALLED BETWEEN BACK OF CURB AND FACE OF SIDEWALK. ALL HYDRANTS SHALL BE LOCATED NO LESS THAN THREE (3) FEET FROM THE EDGE OF PAVEMENT OR BACK OF CURB OF THE ADJACENT ROADWAY AND NO LESS THAN THREE (3) FEET FROM ANY PHYSICAL FEATURE WHICH MAY OBSTRUCT ACCESS OR VIEW OF ANY HYDRANT UNLESS OTHERWISE APPROVED BY THE JEA. THE MAXIMUM DISTANCE (BACK OF CURB) SHALL BE IN COMPLIANCE WITH LOCAL COUNTY FIRE DEPARTMENT RULES AND AS APPROVED BY JEA. FOR OTHER LOCATION LIMITATIONS SEE PLATES W-10 AND W-11. IF PIPING BETWEEN TEE AND HYDRANT IS LONGER THAN 80 LF, AN ADDITIONAL 6" GATE VALVE IS REQUIRED AT THE HYDRANT LOCATION (PROVIDE 30" SEPARATION). ALL PIPING, VALVES AND FITTINGS ALONG THE HYDRANT BRANCH MAIN WHICH IS WITHIN 15 LF OF THE HYDRANT SHALL BE RESTRAINED UTILIZING ONLY TWO 3/4" DIA (THREADED ENDS) STEEL RODS AND EYE BOLTS (NO JOINT RESTRAINT DEVICES REQUIRED). A SPLIT SERRATED RING WITH RESTRAINT EARS (EBAA 15 PF06 or EQUAL) MAYBE USED IN THIS ASSEMBLY. ALL OTHER JOINTS ALONG THE HYDRANT BRANCH MAIN OUTSIDE OF THE FIRST 15 LF SHALL INCLUDE JOINT RESTRAINTS.
3. OPERATION OF THE FIRE HYDRANT SHALL BE EITHER FULL OPEN POSITION OR TOTALLY CLOSED POSITION. THE HYDRANT SHALL NOT BE UTILIZED TO THROTTLE OUTLET FLOW.
4. PRIOR TO PROJECT FINAL INSPECTION, THE HYDRANT AND ALL ABOVE GROUND PIPING SHALL BE RE-OILED, GREASED AND REPAINTED (RUS- KIL ENAMEL-INTERNATIONAL YELLOW OR EQUAL). PRIVATELY OWNED AND MAINTAINED FIRE HYDRANTS SHALL BE PAINTED RED.
5. FIRE HYDRANTS SHALL BE ORDERED WITH PROPER "BURY DEPTH" TO MEET ACTUAL FIELD CONDITIONS. THIS IS ESPECIALLY IMPORTANT FOR BRANCH LINES WHICH TEE-OFF A 12" OR LARGER WATER MAIN. UNLESS APPROVED OTHERWISE BY JEA, THE INSTALLATION OF (45°) BENDS IS NOT ACCEPABLE WHEN UTILIZED TO CORRECT AN IMPROPERLY FURNISHED HYDRANT. THE USE OF HYDRANT EXTENSIONS SHOULD BE MINIMIZED.
6. BLUE REFLECTIVE MARKERS SHALL BE INSTALLED IN SUCH A MANNER THAT THE REFLECTIVE FACE OF THE MARKER IS PERPENDICULAR TO A LINE PARALLEL TO THE ROADWAY CENTERLINE. THE BLUE REFLECTIVE MARKERS SHALL BE PLACED IN THE CENTER OF THE TRAVEL LANE, DIRECTLY ACROSS FROM AND ADJACENT TO EACH FIRE HYDRANT.

FIRE HYDRANT INSTALLATION USING TAPPING SLEEVE & VALVE

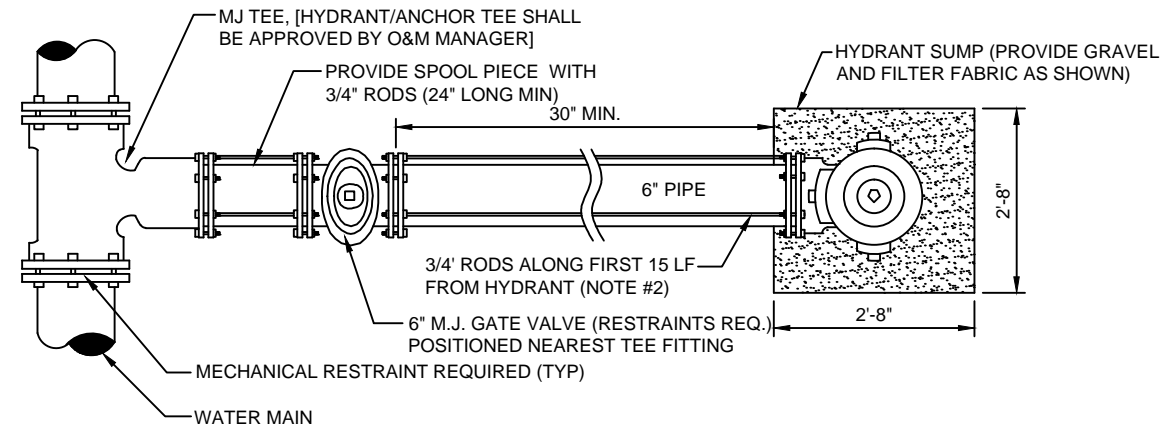

PLAN

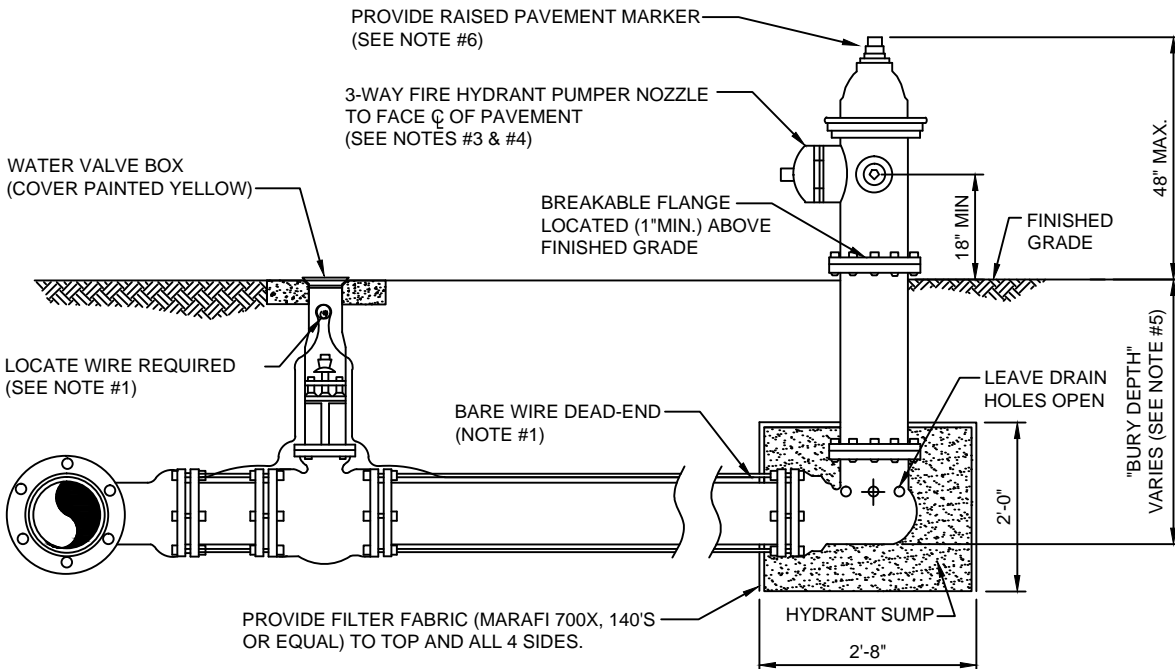

SECTION

NOTES:

1. LOCATE WIRE SHALL BE ROUTED FROM THE VALVE TO THE HYDRANT AS SHOWN ABOVE. THE END OF THE WIRE SHALL BE SECURED TO THE PIPE MAIN. SEE SECTION 350, LOCATE WIRE INSTALLATION PARAGRAPH.
2. FIRE HYDRANTS SHALL BE INSTALLED BETWEEN BACK OF CURB AND FACE OF SIDEWALK AND NOT WITHIN SWALE/DITCH AREAS. THE DISTANCE RANGE FROM EDGE OF ADJACENT PAVEMENT, BACK OF CURB AND FACE OF SIDEWALK SHALL BE IN COMPLIANCE WITH LOCAL COUNTY FIRE DEPARTMENT RULES AND AS APPROVED BY JEA AND APPLICABLE PERMITTING AGENCIES. DISTANCE SHALL BE MEASURED TO THE CLOSEST PART OF THE FIRE HYDRANT (I.E. THE PUMPER NOZZLE). THE MAXIMUM DISTANCE (BACK OF CURB) SHALL BE IN COMPLIANCE WITH LOCAL COUNTY FIRE DEPARTMENT RULES AND AS APPROVED BY JEA. FOR OTHER LOCATION LIMITATIONS SEE PLATES W-10 AND W-11. IF PIPING BETWEEN TEE AND HYDRANT IS LONGER THAN 80 LF, AN ADDITIONAL 6" GATE VALVE IS REQUIRED AT THE HYDRANT LOCATION (PROVIDE 30" SEPARATION). ALL PIPING, VALVES AND FITTINGS ALONG THE HYDRANT BRANCH MAIN WHICH IS WITHIN 15 LF OF THE HYDRANT SHALL BE RESTRAINED UTILIZING ONLY TWO 3/4" DIA (THREADED ENDS) STEEL RODS AND EYE BOLTS (NO JOINT RESTRAINT DEVICES REQUIRED). A SPLIT SERRATED RING WITH RESTRAINT EARS (EBAA 15 PF06 or EQUAL) MAYBE USED IN THIS ASSEMBLY. ALL OTHER JOINTS ALONG THE HYDRANT BRANCH MAIN OUTSIDE OF THE FIRST 15 LF SHALL INCLUDE JOINT RESTRAINTS.
3. OPERATION OF THE FIRE HYDRANT SHALL BE EITHER FULL OPEN POSITION OR TOTALLY CLOSED POSITION. THE HYDRANT SHALL NOT BE UTILIZED TO THROTTLE OUTLET FLOW.
4. PRIOR TO PROJECT FINAL INSPECTION, THE HYDRANT AND ALL ABOVE GROUND PIPING SHALL BE RE-OILED, GREASED AND REPAINTED (RUS- KIL ENAMEL-INTERNATIONAL YELLOW OR EQUAL). PRIVATELY OWNED AND MAINTAINED FIRE HYDRANTS SHALL BE PAINTED RED.
5. FIRE HYDRANTS SHALL BE ORDERED WITH PROPER "BURY DEPTH" TO MEET ACTUAL FIELD CONDITIONS. THIS IS ESPECIALLY IMPORTANT FOR BRANCH LINES WHICH TEE-OFF A 12" OR LARGER WATER MAIN. UNLESS APPROVED OTHERWISE BY JEA, THE INSTALLATION OF (45°) BENDS IS NOT ACCEPTABLE WHEN UTILIZED TO CORRECT AN IMPROPERLY FURNISHED HYDRANT. THE USE OF HYDRANT EXTENSIONS SHOULD BE MINIMIZED.
6. BLUE REFLECTIVE MARKERS SHALL BE INSTALLED IN SUCH A MANNER THAT THE REFLECTIVE FACE OF THE MARKER IS PERPENDICULAR TO A LINE PARALLEL TO THE ROADWAY CENTERLINE. THE BLUE REFLECTIVE MARKERS SHALL BE PLACED IN THE CENTER OF THE TRAVEL LANE, DIRECTLY ACROSS FROM AND ADJACENT TO EACH FIRE HYDRANT.

FIRE HYDRANT INSTALLATION USING MECHANICAL JOINT TEE

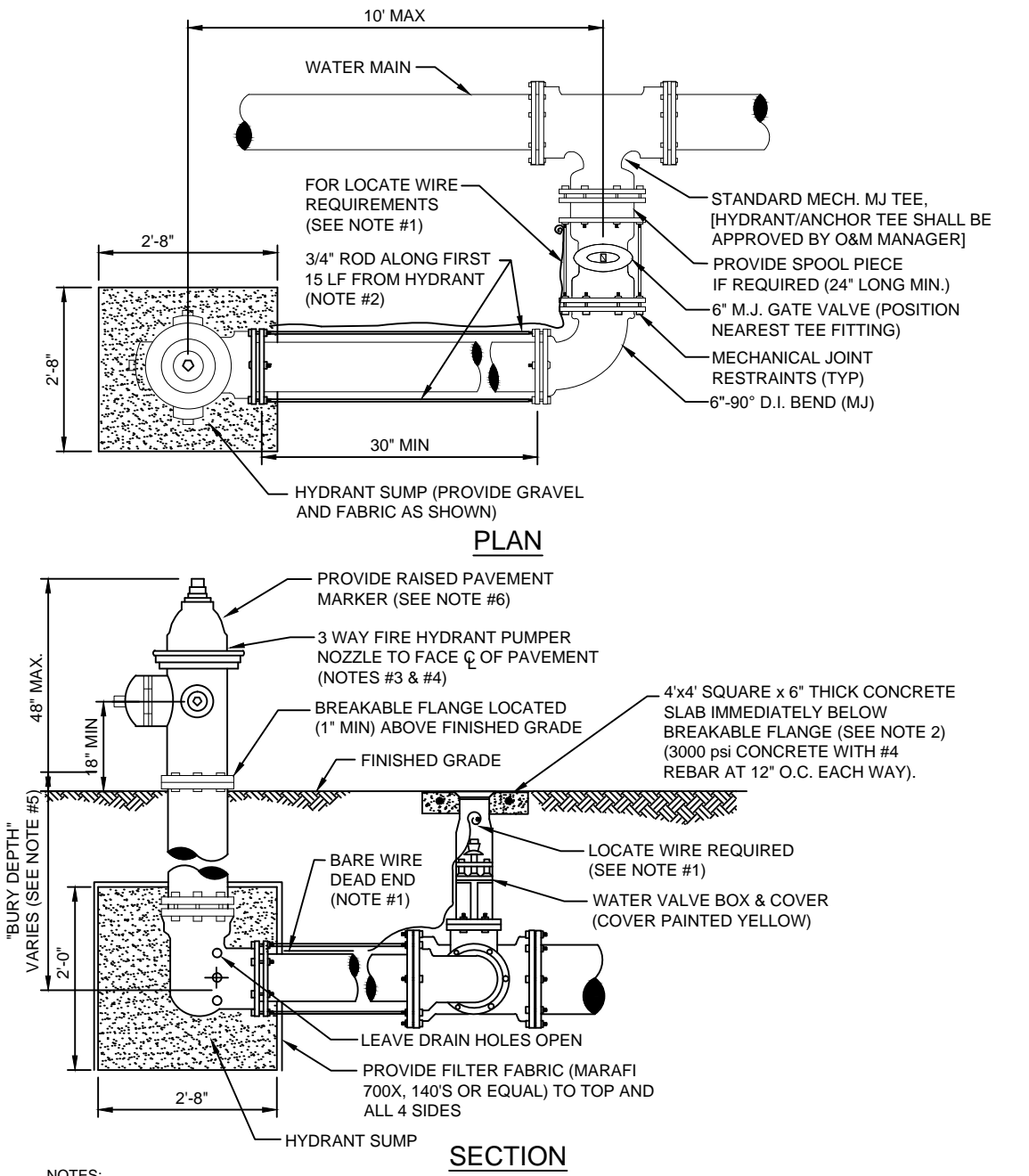

NOTES:

1. LOCATE WIRE SHALL BE ROUTED FROM THE VALVE TO THE HYDRANT AS SHOWN ABOVE. THE END OF THE WIRE SHALL BE SECURED TO THE PIPE MAIN. SEE SECTION 350, LOCATE WIRE INSTALLATION PARAGRAPH.
2. FIRE HYDRANTS SHALL BE INSTALLED BETWEEN BACK OF CURB AND FACE OF SIDEWALK. ALL HYDRANTS SHALL BE LOCATED NO LESS THAN THREE (3) FEET FROM THE EDGE OF PAVEMENT OR BACK OF CURB OF THE ADJACENT ROADWAY AND NO LESS THAN THREE (3) FEET FROM ANY PHYSICAL FEATURE WHICH MAY OBSTRUCT ACCESS OR VIEW OF ANY HYDRANT UNLESS OTHERWISE APPROVED BY THE JEA. THE MAXIMUM DISTANCE (BACK OF CURB) SHALL BE IN COMPLIANCE WITH LOCAL COUNTY FIRE DEPARTMENT RULES AND AS APPROVED BY JEA. FOR OTHER LOCATION LIMITATIONS SEE PLATES W-10 AND W-11. IF PIPING BETWEEN TEE AND HYDRANT IS LONGER THAN 80 LF, AN ADDITIONAL 6" GATE VALVE IS REQUIRED AT THE HYDRANT LOCATION (PROVIDE 30" SEPARATION). ALL PIPING, VALVES AND FITTINGS ALONG THE HYDRANT BRANCH MAIN WHICH IS WITHIN 15 LF OF THE HYDRANT SHALL BE RESTRAINED UTILIZING ONLY TWO 3/4" DIA (THREADED ENDS) STEEL RODS AND EYE BOLTS (NO JOINT RESTRAINT DEVICES REQUIRED). A SPLIT SERRATED RING WITH RESTRAINT EARS (EBAA 15 PF06 or EQUAL) MAYBE USED IN THIS ASSEMBLY. ALL OTHER JOINTS ALONG THE HYDRANT BRANCH MAIN OUTSIDE OF THE FIRST 15 LF SHALL INCLUDE JOINT RESTRAINTS.
3. OPERATION OF THE FIRE HYDRANT SHALL BE EITHER FULL OPEN POSITION OR TOTALLY CLOSED POSITION. THE HYDRANT SHALL NOT BE UTILIZED TO THROTTLE OUTLET FLOW.
4. PRIOR TO PROJECT FINAL INSPECTION, THE HYDRANT AND ALL ABOVE GROUND PIPING SHALL BE RE-OILED, GREASED AND REPAINTED (RUS- KIL ENAMEL-INTERNATIONAL YELLOW OR EQUAL). PRIVATELY OWNED AND MAINTAINED FIRE HYDRANTS SHALL BE PAINTED RED.
5. FIRE HYDRANTS SHALL BE ORDERED WITH PROPER "BURY DEPTH" TO MEET ACTUAL FIELD CONDITIONS. THIS IS ESPECIALLY IMPORTANT FOR BRANCH LINES WHICH TEE-OFF A 12" OR LARGER WATER MAIN. UNLESS APPROVED OTHERWISE BY JEA, THE INSTALLATION OF (45°) BENDS IS NOT ACCEPTABLE WHEN UTILIZED TO CORRECT AN IMPROPERLY FURNISHED HYDRANT. THE USE OF HYDRANT EXTENSIONS SHOULD BE MINIMIZED.
6. BLUE REFLECTIVE MARKERS SHALL BE INSTALLED IN SUCH A MANNER THAT THE REFLECTIVE FACE OF THE MARKER IS PERPENDICULAR TO A LINE PARALLEL TO THE ROADWAY CENTERLINE. THE BLUE REFLECTIVE MARKERS SHALL BE PLACED IN THE CENTER OF THE TRAVEL LANE, DIRECTLY ACROSS FROM AND ADJACENT TO EACH FIRE HYDRANT.

FIRE HYDRANT INSTALLATION LIMITED SPACE

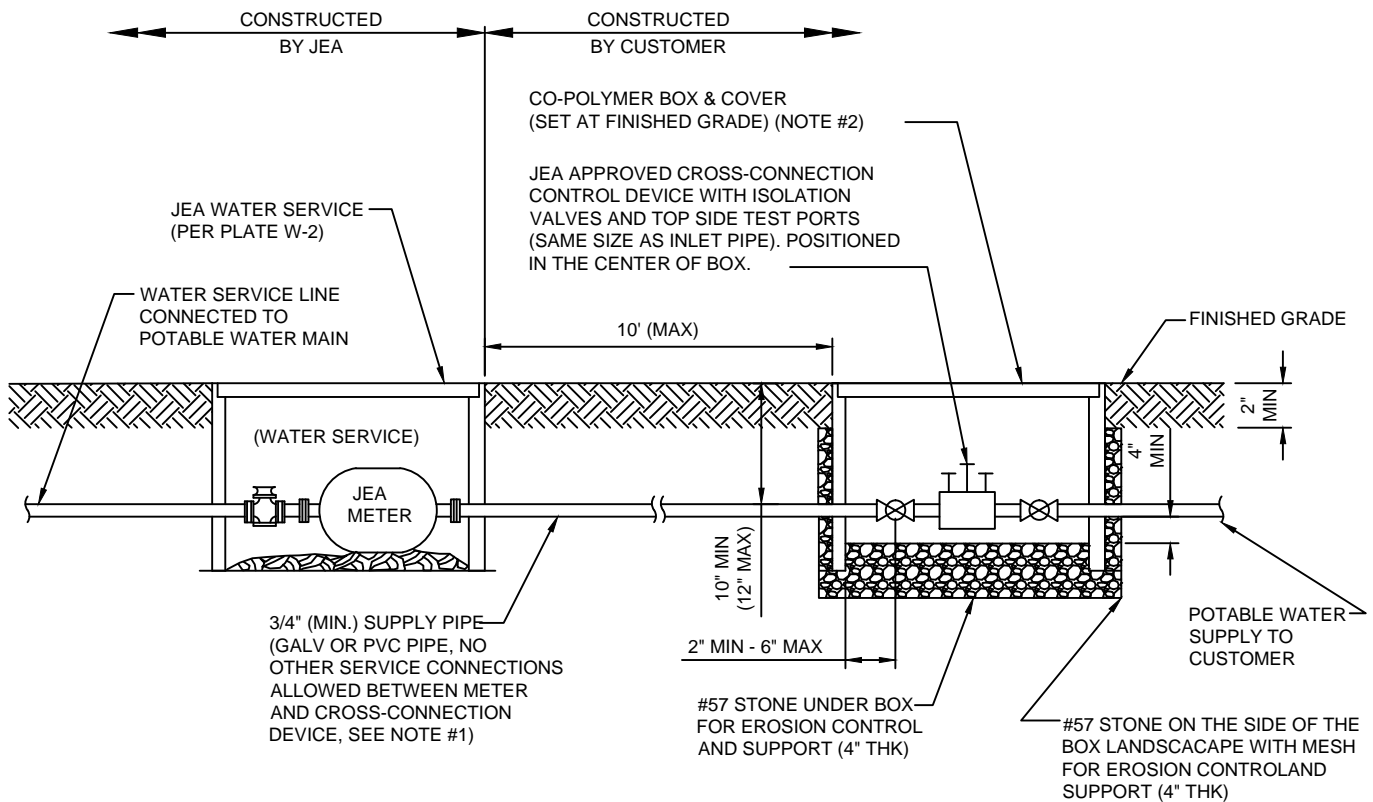

NOTES:

1. THE POTABLE WATER CUSTOMER IS REQUIRED TO INSTALL AND MAINTAIN A JEA APPROVED CROSS-CONNECTION DEVICE ON THEIR POTABLE WATER SERVICE LINE. OPERATION AND MAINTENANCE OF THIS CROSS-CONNECTION DEVICE SHALL COMPLY WITH JEA'S CROSS-CONNECTION CONTROL PROGRAM AND ASSOCIATED OPERATIONS POLICIES. ALL REDUCED PRESSURE ASSEMBLIES SHALL BE MOUNTED ABOVE GRADE.
2. ONLY DOUBLE CHECK VALVE ASSEMBLIES MAY BE INSTALLED BELOW GROUND. THESE DEVICES MAY BE INSTALLED IN A TYPICAL 1" (CO-POLYMER) METER BOX WITH SOLID LID (GENERIC LID WITH NO "JEA" LOGO, SEE ALSO W-3). THE SIZE OF BOX SHALL BE 12"x20", AT A MINIMUM. IT SHALL BE NOTED THAT IF THE HIGH MEAN GROUND WATER LEVEL FALLS INSIDE THIS BOX, THEN THE CROSS-CONNECTION CONTROL DEVICE MUST BE INSTALLED ABOVE GROUND. ACCEPTABLE DOUBLE CHECK VALVE ASSEMBLIES (BRONZE BODY WITH TWO CHECK VALVES, TWO BALL VALVES AND UNION CONNECTIONS BETWEEN BALL VALVES AND THE DEVICE). INCLUDE: WATTS U007M2QT, WILKINS 950XLTU OR JEA APPROVED EQUAL.
3. BACKFLOW PREVENTION DEVICES REQUIRED WHEN:
 IRRIGATION SYSTEMS - REQUIRED ON IRRIGATION SYSTEMS AT THE CONNECTION TO POTABLE SYATEM
 RESIDENTIAL SYSTEMS - REQUIRED ON WATER SERVICE IF RECLAIMED SERVICE WATER AVAILABLE TO SITE
 COMMERCIAL SITES - REQUIRED ON ALL WATER SERVICES
 INDUSTRIAL SITES - REQUIRED ON BOTH WATER AND RECLAIMED SERVICE ON, WATER SERVICE EVEN IF NO RECLAIMED
4. JEA IRRIGATION SERVICE CONNECTIONS REQUIRE ABOVE GRADE REDUCED PRESSURE BACKFLOW PREVENTERS. (SEE PLATE W-15A)

RECLAIM CROSS CONNECTION CONTROL DEVICE

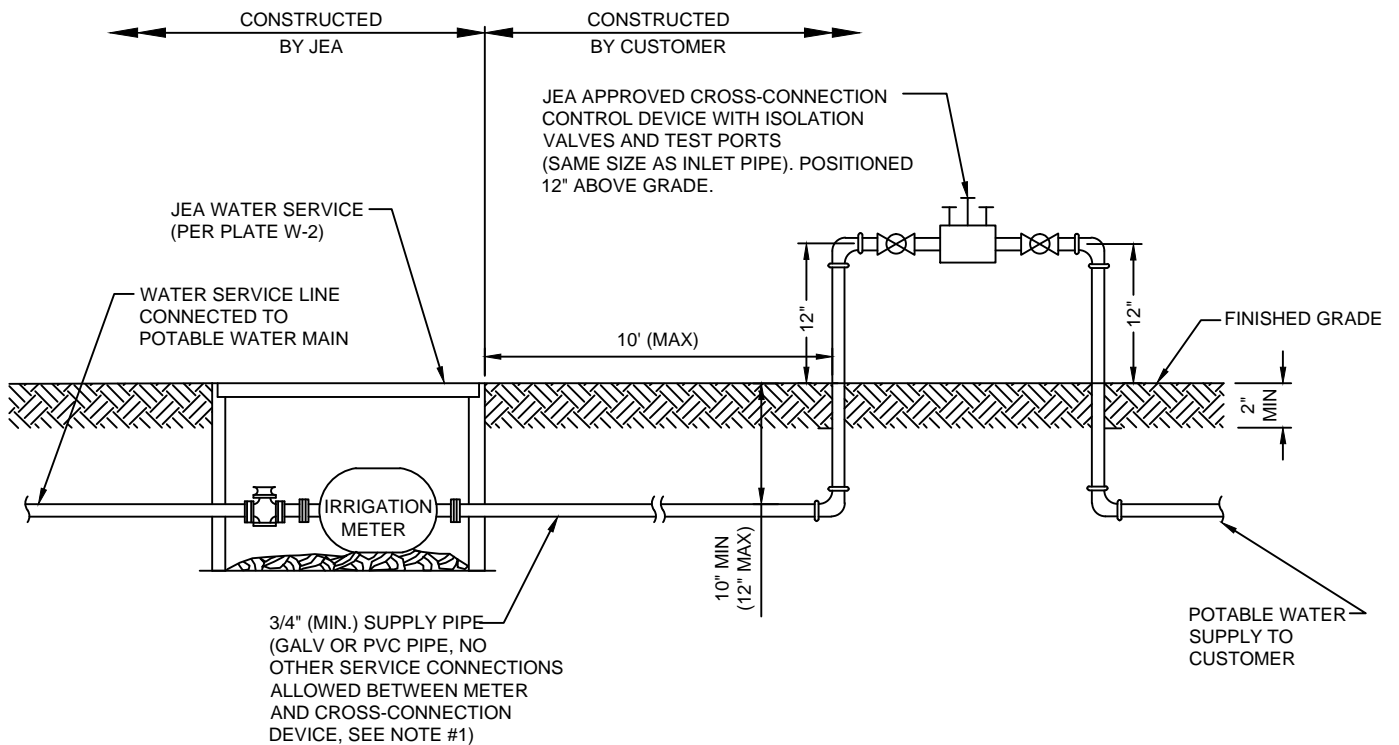

NOTES:

1. WATER SERVICE CONNECTIONS REQUIRE ABOVE GRADE REDUCED PRESSURE BACKFLOW PREVENTERS. (SEE PLATE W-15)
2. BACKFLOW PREVENTION DEVICES REQUIRED WHEN:
 IRRIGATION SYSTEMS - REQUIRED ON IRRIGATION SYSTEMS AT THE CONNECTION TO POTABLE SYSTEM
 RESIDENTIAL SYSTEMS - REQUIRED ON WATER SERVICE IF RECLAIMED SERVICE WATER AVAILABLE TO SITE
 COMMERCIAL SITES - REQUIRED ON ALL WATER SERVICES
 INDUSTRIAL SITES - REQUIRED ON BOTH WATER AND RECLAIMED SERVICE CONNECTIONS.
3. RESIDENTIAL IRRIGATION SERVICES MAY UTILIZE AN ALTERNATE BACKFLOW PREVENTER LOCATION IF THE FOLLOWING CONDITIONS EXITS:
 - 3.a. CUSTOMER HAS SUBMITTED A COMPLETED "CUSTOMER AFFIDAVIT" FORM AND
 - 3.b. THERE ARE NO ADDITIONAL CONNECTIONS BETWEEN THE METER AND THE BACKFLOW PREVENTER, AND
 - 3.c. THE ALTERNATE BACKFLOW LOCATION IS EASILY ACCESSIBLE TO JEA AND BACKFLOW TESTERS.

CROSS CONNECTION CONTROL DEVICE

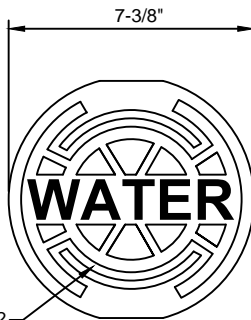

SEE NOTES #1 & #2

HEAVY DUTY RATING

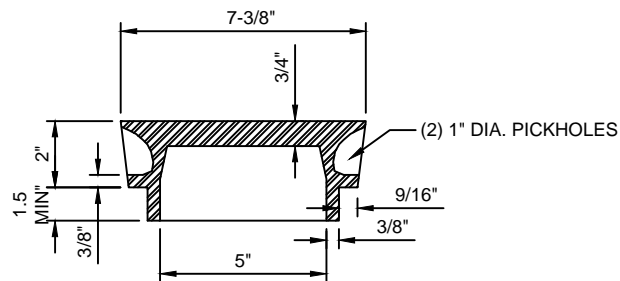

NOTES:

1. PAINT TOP OF THE COVER WITH ENAMEL PAINT (BLUE COLOR) FOR WATER.
2. FOR "REUSE" PAINT TOP PANTONE PURPLE.
3. LID WEIGHT: APPROX. 12 LBS.

WATER SYSTEM VALVE BOX COVER

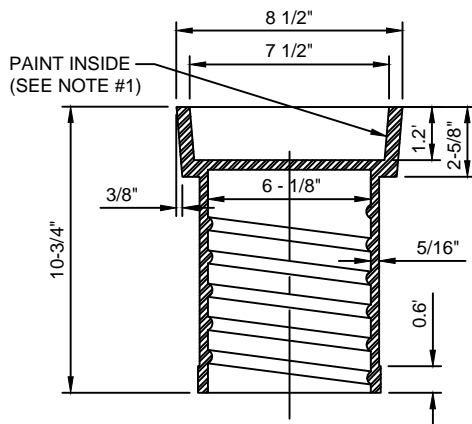

HEAVY DUTY RATING

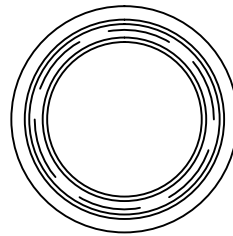

TOP SECTION VIEW

(23 LBS. APPROX.)

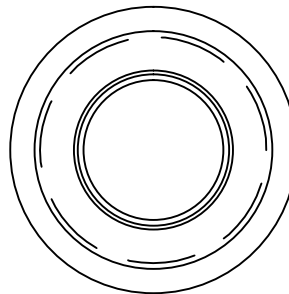
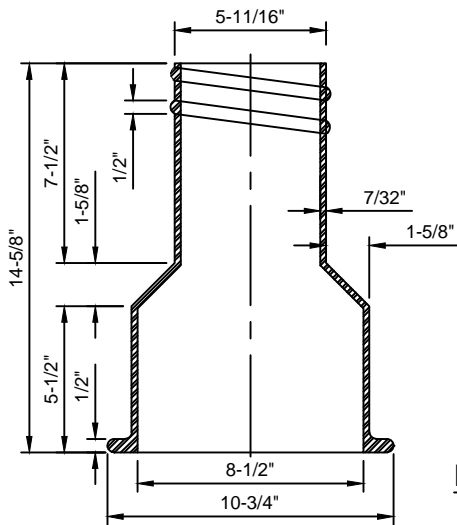

BOTTOM SECTION VIEW

(26 LBS. APPROX.)

NOTES:

1. PAINT THE INSIDE OF THE TOP SECTION OF THE BOX WITH APPLICABLE COLOR (BLUE OR PURPLE)
2. HEAVY DUTY RATING (TOTAL WEIGHT APPROX. 50 LBS.).
3. REFERENCE SECTION 351, PARAGRAPH X.2.

WATER SYSTEM VALVE BOX

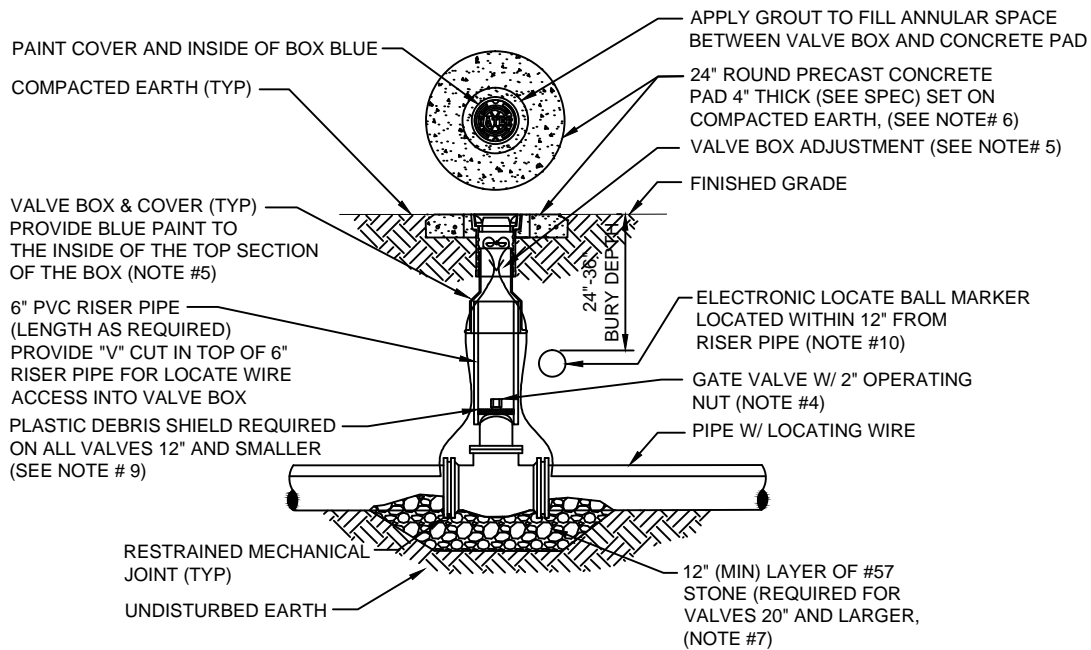

NOTES:

1. FOR UNPAVED LOCATIONS, A PRECAST CONCRETE VALVE PAD SHALL BE PROVIDED AND INSTALLED FLUSH WITH GRADE. CONCRETE PAD IS NOT REQUIRED FOR VALVE LOCATED IN THE ROADWAY, UNLESS SHOWN OR NOTED OTHERWISE.
2. LOCATING WIRE IS REQUIRED ON ALL PRESSURE PIPING (SEE DETAILW-44).
3. A "V" CUT SHALL BE CARVED IN THE CURB CLOSEST/ADJACENT/(ASPHALT IF NO CURB) TO ALL BELOW GRADE VALVES. THE "V" CUT IS TO BE PAINTED BLUE WATER/PURPLE RECLAIMED.
4. IN PAVED AREAS, INSTALL VALVE AT A DEPTH TO ALLOW A 12" MIN. DISTANCE BETWEEN THE VALVE COVER PLATE AND THE TOP OF THE VALVE OPERATING NUT. OUTSIDE OF PAVED AREAS (GRASS), INSTALL VALVE AT A DEPTH TO ALLOW A 6" MINIMUM DISTANCE BETWEEN THE VALVE COVER AND THE TOP OF THE VALVE OPERATING NUT. OPERATING NUT/STEM EXTENSION SHALL BE PROVIDED (WHERE APPLICABLE) SO THAT THE OPERATING NUT WILL BE NO MORE THAN 30 INCHES BELOW FINISHED GRADE.
5. FOR NEW CONSTRUCTION, THE VALVE BOX SHALL BE ADJUSTED TO MIDRANGE TO ALLOW FOR FUTURE BOX ADJUSTMENTS. ROUTE LOCATE WIRES THRU A "V" CUT IN THE TOP OF THE 6" PVC RISER PIPE FOR LOCATE WIRE ACCESS INTO VALVE BOX. THE LOCATE WIRES WITH A 24" LONG PIG-TAIL AT THE TOP SHALL BE CONNECTED TOGETHER WITH A WIRE NUT.
6. BRASS IDENTIFICATION TAG INDICATING "WATER", VALVE SIZE, DIRECTION AND TURNS TO OPEN & VALVE TYPE. PROVIDE A 1/2" HOLE IN BRASS TAG AND ATTACH TAG (TWIST WIRE AROUND TAG) TO THE END OF THE LOCATE WIRE. TAGS ARE NOT REQUIRED ON VALVES INSTALLED ON FIRE HYDRANT BRANCH LINES.
7. IN LIEU OF PRECAST CONCRETE PAD, A 6" THICK X 24" (ROUND OR SQUARE) POURED CONCRETE PAD W/2 - #4 REBAR AROUND PERIMETER, MAY BE USED.
8. GRAVEL SHALL BE PROVIDED UNDER ALL VALVES 20" AND LARGER. THE MINIMUM VERTICAL LIMIT OF GRAVEL IS 12" UNDER THE VALVE UP TO 2/3 THE OVERALL HEIGHT OF THE VALVE.
9. FOR VALVES 12 INCH AND SMALLER, PROVIDE A WHITE OR BLACK PLASTIC DEBRIS SHIELD WHICH INSTALLS BELOW THE OPERATING NUT. THIS SHIELD SHALL CENTER THE RISER PIPE BOX OVER THE OPERATING NUT AND MINIMIZE INFILTRATION. SHIELD SHALL BE BY AFC, BOXLOK OR APPROVED EQUAL.
10. ALL VALVES SHALL BE INSTALLED WITH AN ELECTRIC LOCATE MARKER. MARKER SHALL BE 4" DIA. COLOR CODED BALL MARKER (3M-1403XR FOR WATER AND 1408XR FOR RECLAIMED WATER).

WATER VALVE INSTALLATION DETAIL

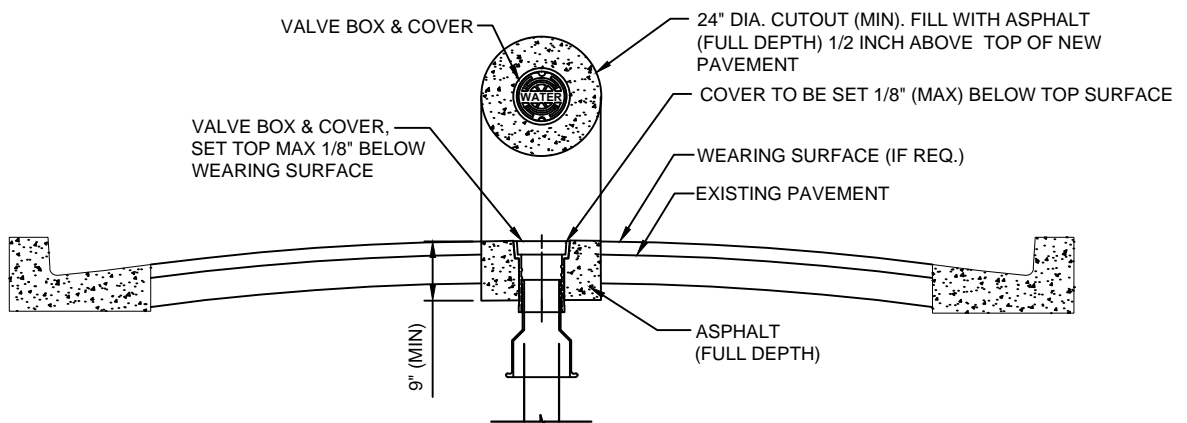

NOTES:

1. PROVIDE FULL DEPTH ASPHALT 1/2 INCH ABOVE TOP OF NEW PAVEMENT LEVEL, TO ALLOW FOR FUTURE ASPHALT MATERIAL COMPACTION. PLACE AND COMPACT ASPHALT IN 2" (MAX) LIFTS.

WATER VALVE JACKET ADJUSTED TO ROADWAY AFTER RE-SURFACING

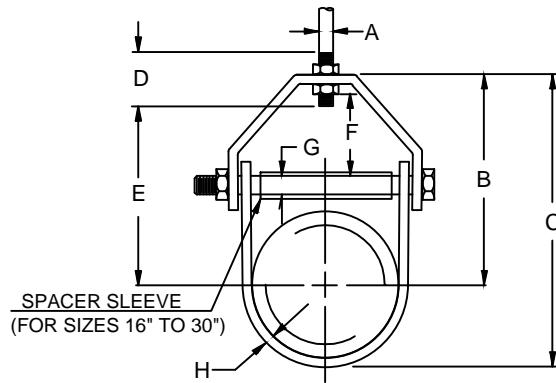

PIPE SIZE	MAX LOAD	SPAN (FT)	WEIGHT	ROD SIZE A	B	C	ROD TAKE OUT E	ADJUST. F	G	H WIDTH LOWER
4	1430	14	1.51	5/8	5-9/16	7-13/16	4-1/2	1-11/16	3/8	1-1/4
6	1940	17	3.10	3/4	6-15/16	10-1/4	5-3/4	1-11/16	1/2	1-7/16
8	2000	19	4.75	3/4	8-3/8	12-11/16	7-3/16	2	1/2	1-7/16
10	3600	22	8.60	7/8	9-7/8	15-1/4	8-7/16	2-1/8	5/8	1-3/4
12	3800	23	11.20	7/8	11-9/16	17-15/16	10-1/8	2-13/16	5/8	2
16	4600	27	19.85	1	14	22	12	2-3/4	1	2-1/2
20	4800	30	40.33	1-1/4	17-9/16	27-9/16	15-3/16	3-7/8	1-1/4	3
24	4800	32	49.83	1-1/4	19-13/16	31-13/16	17-5/16	3-7/8	1-1/4	3
30	6000	33	70.18	1-1/4	24-3/16	39-3/16	21-9/16	5-1/8	1-1/4	3

NOTES :

1. ALL HANGER COMPONENTS SHALL BE 316 STAINLESS STEEL UNLESS OTHERWISE NOTED. ALL CUT ENDS SHALL HAVE ROUNDED CORNERS.
2. PROVIDE A HANGER AT EACH PIPE BELL. ADDITIONAL HANGERS SHALL BE SPACED AT TEN (10) FOOT CENTERS (MAX).
3. PIPE HANGERS LARGER THAN 12" SIZE SHALL BE SPECIFICALLY DESIGNED FOR HORIZONTAL AND VERTICAL STRUCTURAL SUPPORT. FOR LARGER MAINS, HORIZONTAL SUPPORT MAY BE ACHIEVED BY EXTENDING THE BOTTOM ANGLE TO SPAN BETWEEN TWO EXISTING CONCRETE BEAMS (NOT DIRECTLY CONNECTED TO CONCRETE BEAMS).
4. THE DIMENSION PROVIDED ABOVE MAY VARY DEPENDING ON ACTUAL FIELD CONDITIONS.
5. FOR CROSSINGS OVER 250 LINEAR FEET, THE USE OF FLEXIBLE EXPANSION JOINTS SHALL BE UTILIZED.
6. TO MINIMIZE THE SNAKING ALIGNMENT OF D.I.P. MAIN, ALL RESTRAINED JOINTS SHALL BE CONDITIONS. BE UTILIZED. DEVICE (PLEASE CONSULT RESTRAINT MANUFACTURER - VERY IMPORTANT). HOMED TOGETHER AND THEN PULLED-BACK SLIGHTLY TO CORRECTLY SET THE RESTRAINT RESTRAINT DEVICE (PLEASE CONSULT RESTRAINT MANUFACTURER - VERY IMPORTANT).

BRIDGE DECK PIPE HANGER DETAIL

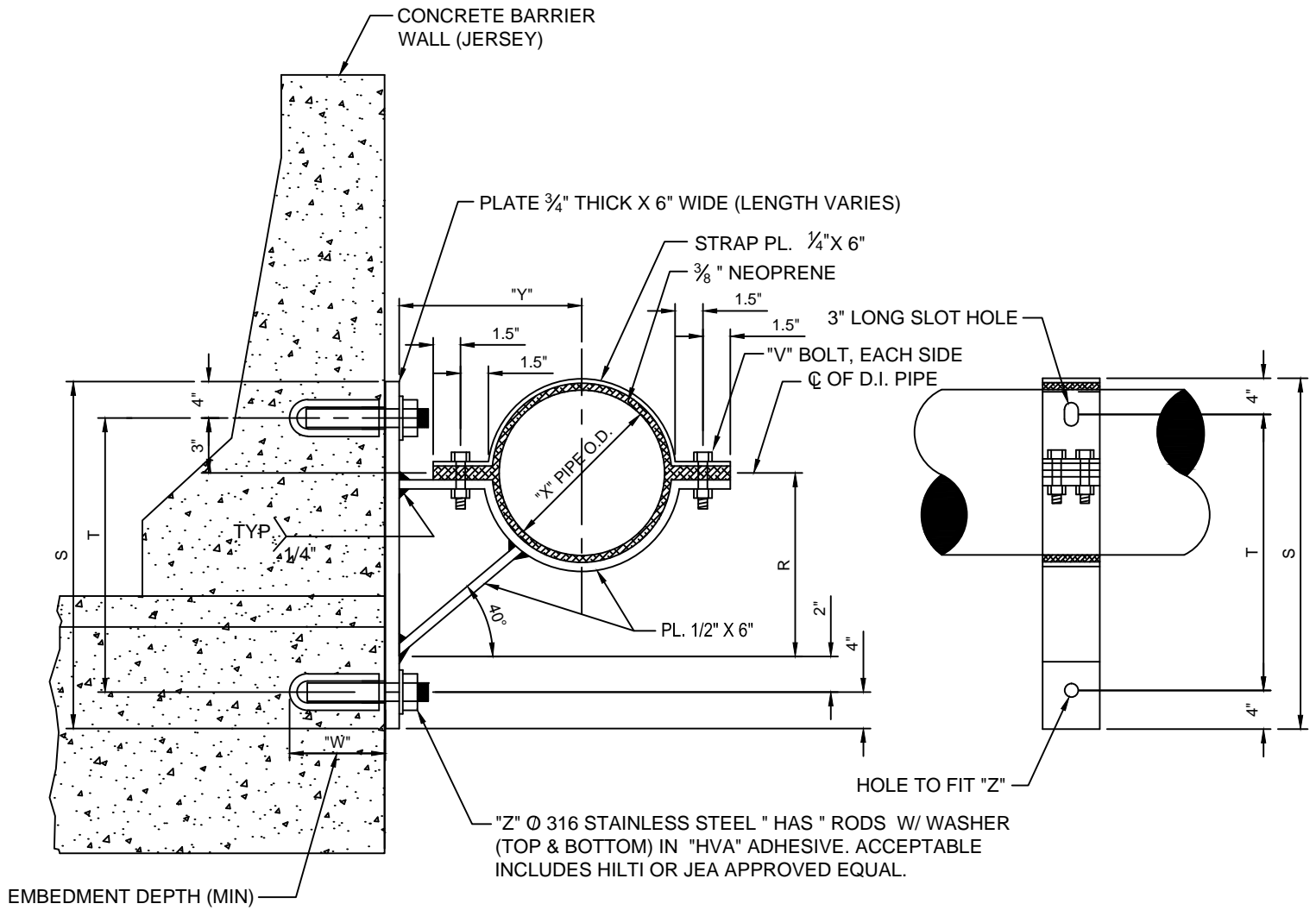

CROSS-SECTION

PROFILE

PIPE SIZE	4"	6"	8"	10"	12"	16"	20"	24"
X	4.80"	6.90"	9.05"	11.10"	13.20"	17.40"	21.60"	25.80"
Y	8"	9"	10"	12"	13"	15"	17"	19"
Z	$\frac{3}{4}$ "	$\frac{3}{4}$ "	$\frac{3}{4}$ "	1"	1"	1"	1 $\frac{1}{4}$ "	1 $\frac{1}{4}$ "
W	6.625"	6.625"	6.625"	8.25"	8.25"	8.25"	12"	12"
V	$\frac{1}{2}$ "	$\frac{1}{2}$ "	$\frac{1}{2}$ "	$\frac{1}{2}$ "	$\frac{1}{2}$ "	$\frac{3}{4}$ "	$\frac{3}{4}$ "	$\frac{3}{4}$ "
R	6.72"	7.55"	8.39"	10.07"	10.91"	12.59"	14.27"	15.94"
S	19.71"	20.55"	21.39"	23.07"	23.91"	25.59"	27.26"	28.94"
T	11.72"	12.55"	13.39"	15.07"	15.91"	17.58"	19.26"	20.94"

NOTES:

1. ALL WELDS TO BE PERFORMED BY A CERTIFIED STRUCTURAL WELDER.
2. ALL SUPPORT BRACKET MEMBERS SHALL BE HOT DIPPED GALVANIZED AFTER FABRICATION.
3. ALL NUTS, BOLTS, AND WASHERS SHALL BE 316 STAINLESS STEEL.
4. THE SPACING OF SIDEWALL PIPE SUPPORTS SHALL BE SPECIFICALLY DESIGNED BASED UPON MANY FACTS INCLUDING PIPE SIZE AND MATERIAL EMBEDEMENT LIMITATIONS. UNLESS APPROVED OTHERWISE BY JEA, IN NO CASE SHALL THE SPACING OF PIPE SUPPORTS EXCEED TWENTY (20) FEET ON-CENTER FOR PIPE SIZES TWELVE (12) INCH AND SMALLER AND TEN (10) FEET ON-CENTER FOR PIPE SIZES GREATER THAN TWELVE (12) INCHES.

SIDEWALL PIPE HANGER DETAIL

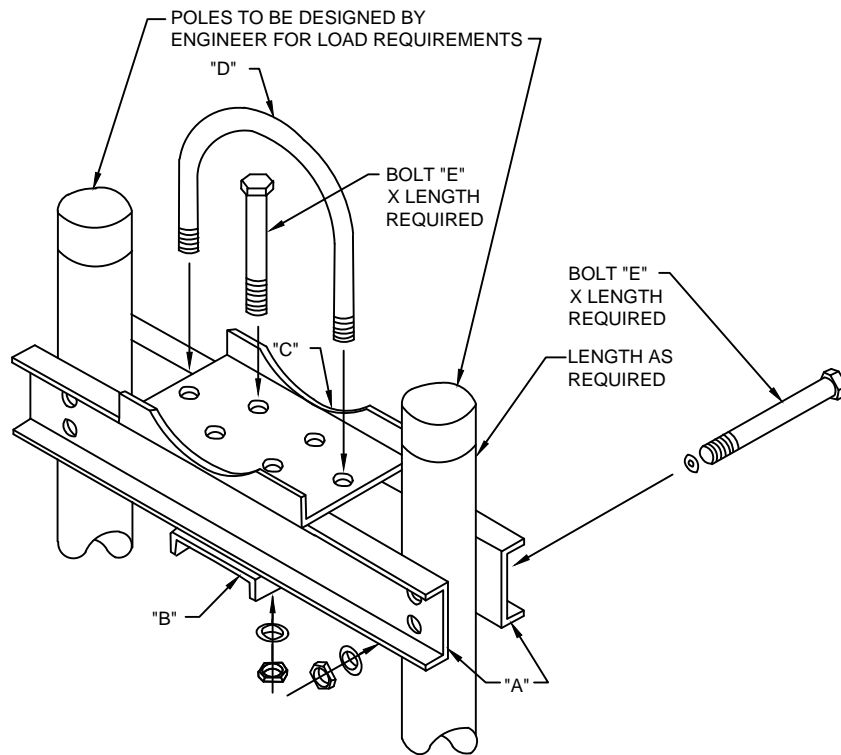

MATERIAL SCHEDULE

ITEM	PIPE 4"-14"		PIPE 16"-24"	
A	8"	[11.5	12"	[25.0
B	10"	[15.3	12"	[25.0
C	12"	[25.0	12"	[25.0
D	1/2" U-BOLT		1-1/8" U-BOLT	
E	3/4" U-BOLT		1-1/8" U-BOLT	

NOTES:

1. ALL PARTS AND FITTINGS TO BE HOT DIPPED GALVANIZED AFTER FABRICATION SEE PLATE S-37 FOR ADDITIONAL DETAILS.
2. AT A MINIMUM, ONE PIPE SUPPORT SHALL BE PROVIDED FOR EACH LENGTH OF (D.I.P.) PIPE UNLESS LONG-SPAN (D.I.P.) PIPE ASSEMBLIES ARE PROVIDED.

PIPE SUPORT & POLE ASSEMBLY FOR WATER MAIN

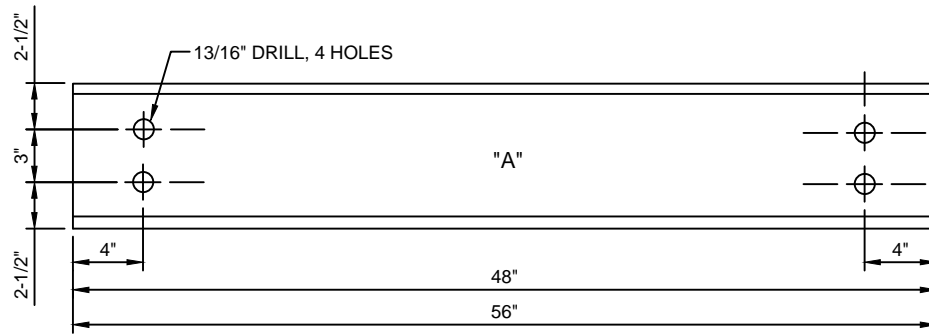

"A" STANDARD 8" CHANNEL 11.5 LBS.

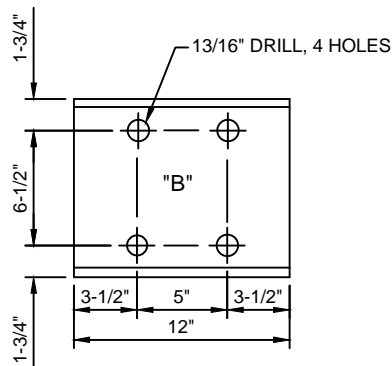

"B" STANDARD 10" CHANNEL 15.3 LBS.

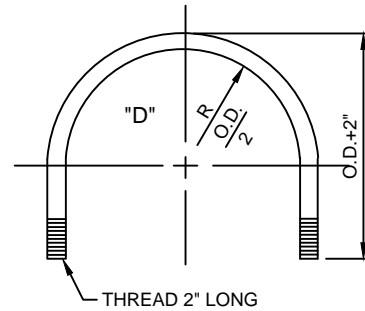

"D" 1/2" U-BOLT

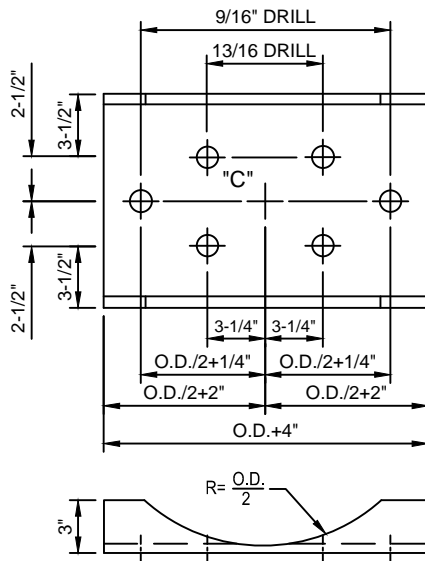

"C" STANDARD 12" CHANNEL 25 LBS.

D.I. PIPE	O.D. APPROX
3"	4.71"
4"	5.55"
6"	7.65"
8"	9.80"
10"	11.85"
12"	13.95"
14"	16.05"
16"	18.15"
18"	20.25"
20"	22.35"
24"	26.55"

TABLE

NOTES:

- FOR PIPE 16" AND LARGER, UTILIZE CHANNEL SIZES AS SCHEDULED ON PLATE W-22, BUT CUSTOMIZE BOLT PATTERN DIMENSIONS TO FIT PIPE SIZE. SEE PLATE W-22 FOR ASSEMBLY LAYOUT.

PIPE SUPPORT DETAILS FOR POLE ASSEMBLY

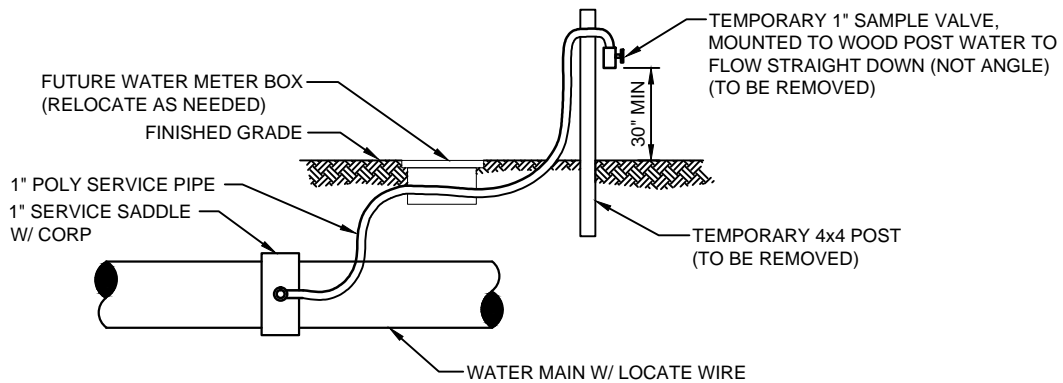

TEMPORARY SAMPLE TAP UTILIZING A NEW 1" WATER SERVICE

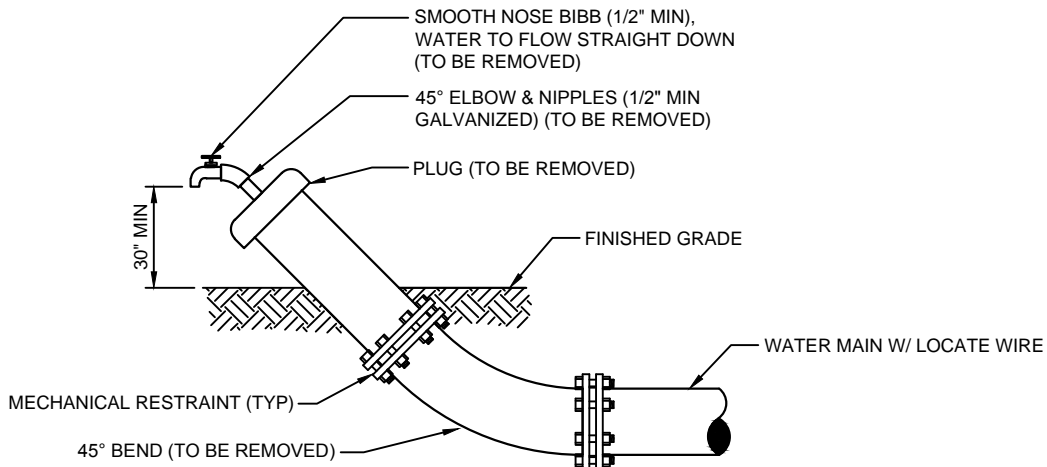

TEMPORARY SAMPLE TAP UTILIZING PLUG AT FLUSHING LOCATION

NOTES:

1. LOCATION OF SAMPLE POINT BIBB SHALL NOT BE WITHIN THE ROADWAY BUT ROUTED TO THE ROAD SHOULDERS.
2. THE CONTRACTOR SHALL BE RESPONSIBLE FOR THE REMOVAL OF ALL TEMPORARY PIPING & FITTINGS (AS NOTED) AFTER BACTERIOLOGICAL CLEARANCE IS RECEIVED.
3. THE CONTRACTOR SHALL UTILIZE THE ABOVE ALTERNATIVE METHODS FOR CONSTRUCTION OF TEMPORARY SAMPLE POINTS IN ALL AREAS, WHERE POSSIBLE.
4. THE CONTRACTOR SHALL COMPLY WITH ALL JEA RULES AND POLICIES AS OUTLINED BY THE JEA'S ENVIRONMENTAL RESPONSE COORDINATOR (ERC) AND OTHER ASSOCIATED JEA STANDARDS.

TEMPORARY SAMPLE TAP ALTERNATIVE METHODS

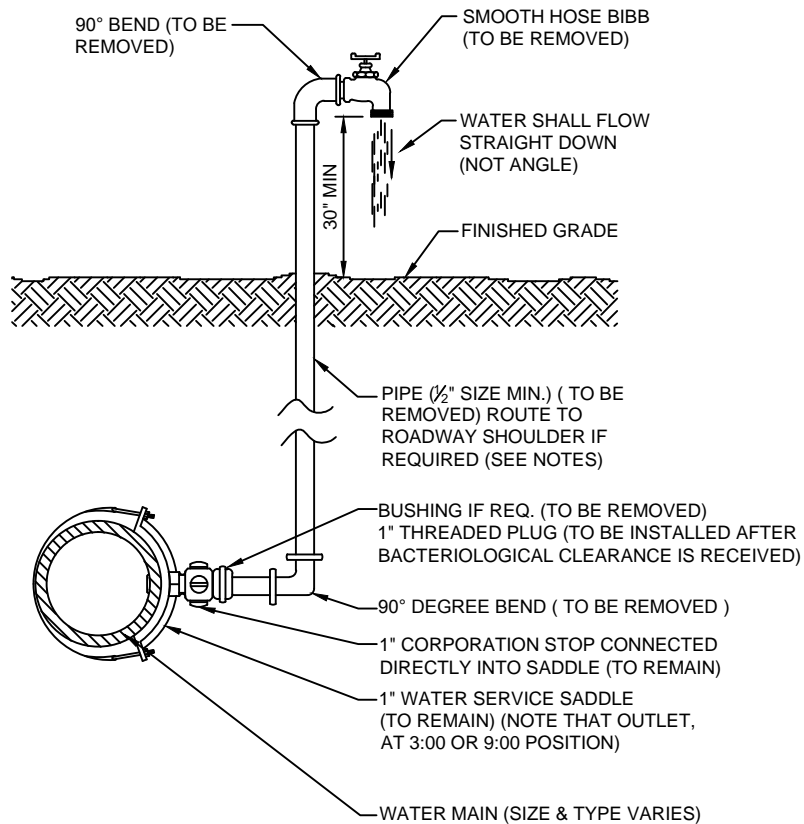

NOTES:

1. LOCATION OF SAMPLE POINT BIBB SHALL NOT BE WITHIN THE ROADWAY BUT ROUTED TO THE ROADWAY SHOULDERS (NON-TRAFFIC AREAS).
2. THE CONTRACTOR SHALL BE RESPONSIBLE FOR THE REMOVAL OF ALL TEMPORARY PIPING & FITTINGS (AS NOTED), AFTER BACTERIOLOGICAL CLEARANCE IS RECEIVED.
3. PIPE AND FITTINGS SHALL BE PVC (SCH. 40) OR GALV. MATERIAL.
4. THE USE OF THE ABOVE CONSTRUCTION FOR A TEMPORARY SAMPLE POINT SHALL BE LIMITED TO AREAS WHERE A SAMPLE TAP BY ALTERNATIVE METHODS (SEE W-24) IS NOT FEASIBLE OR IF DIRECTED OTHERWISE BY JEA.
5. THE CONTRACTOR SHALL COMPLY WITH ALL JEA RULES AND POLICIES AS OUTLINED BY JEA'S ENVIRONMENTAL RESPONSE COORDINATOR (ERC) AND OTHER ASSOCIATED JEA STANDARDS.

TEMPORARY SAMPLE TAP

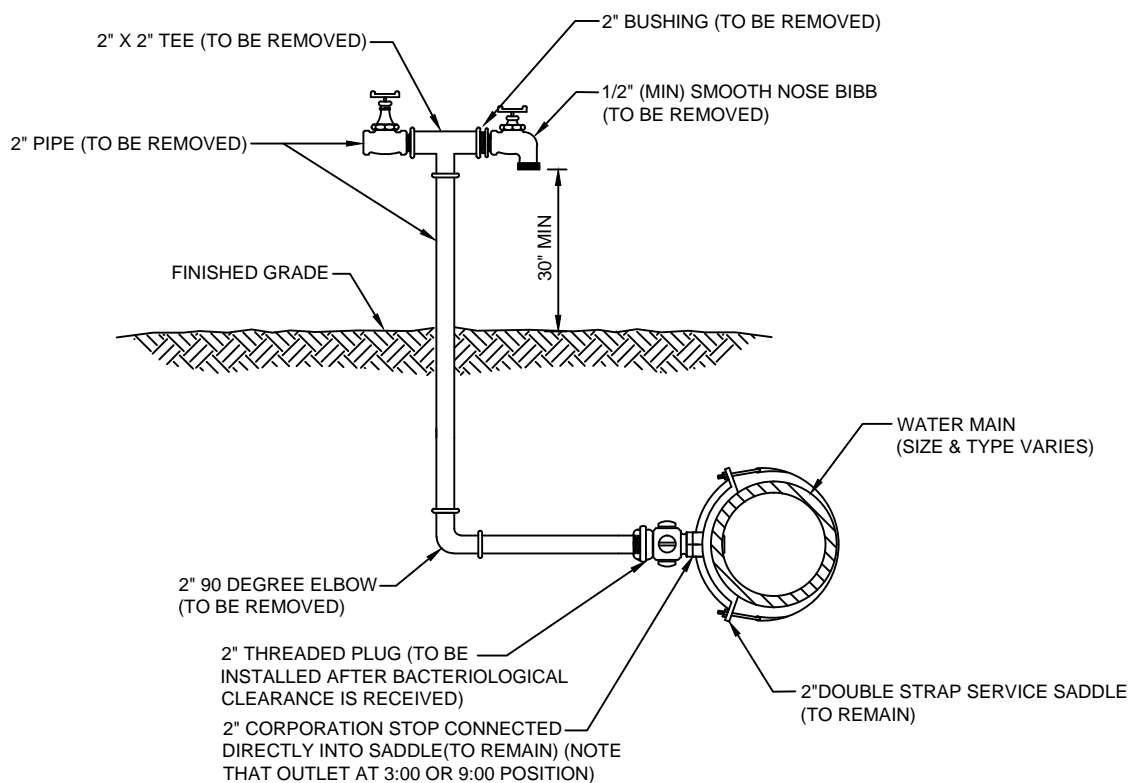

NOTES:

1. LOCATION OF SAMPLE POINT BIBB SHALL NOT BE WITHIN THE ROADWAY BUT ROUTED TO THE ROADWAY SHOULDERS (NON-TRAFFIC AREAS).
2. ALL PIPE & FITTING SHALL BE GALVANIZED MATERIAL OR PVC (S-40).
3. THE CONTRACTOR SHALL BE RESPONSIBLE FOR THE REMOVAL OF ALL TEMPORARY PIPING & FITTING (AS NOTED) AFTER BACTERIOLOGICAL CLEARANCE IS RECEIVED
4. THE CONTRACTOR SHALL COMPLY WITH ALL JEA RULES AND POLICES AS OUTLINED BY THE JEA'S ENVIRONMENTAL RESPONSE COORDINATOR (ERC) AND OTHER ASSOCIATED JEA STANDARDS.

2" TEMPORARY SAMPLE TAP FOR STUB OUT

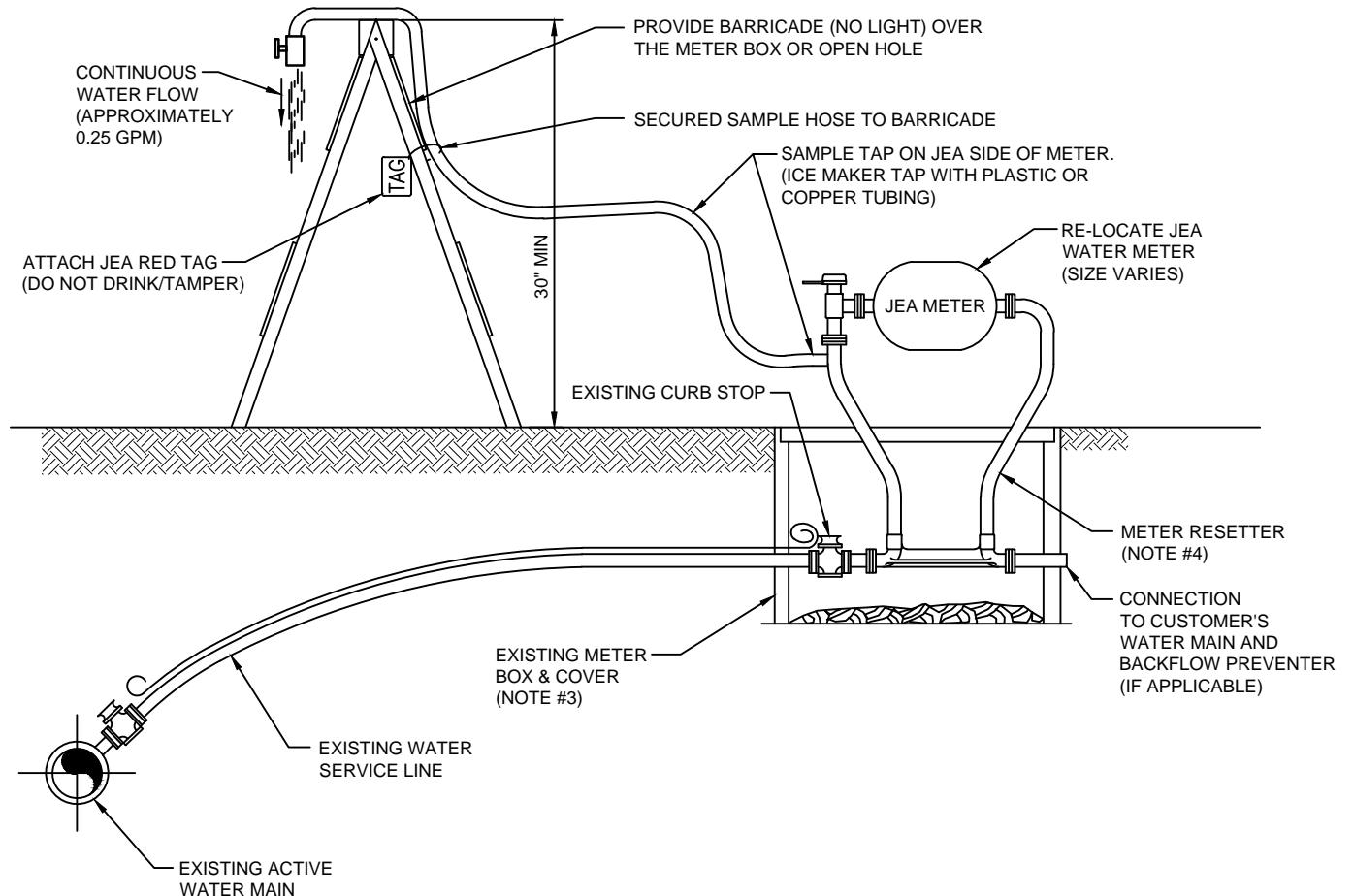

NOTES :

1. THE ABOVE TEMPORARY WATER SAMPLE TAP IS FOR USE ON ACTIVE WATER MAINS. GENERALLY, THIS SAMPLE TAP IS INSTALLED ADJACENT TO EACH WATER MAIN VALVE BEING CLOSED DURING A WATER OUTAGE. WHEN REQUIRED, THE CONTRACTOR SHALL PROVIDE THE ABOVE TEMPORARY SAMPLE TAP AND THEN REMOVE/RESTORE THE WATER METER SERVICE AFTER BACTERIOLOGICAL CLEARANCE.
2. THE CONTRACTOR SHALL COMPLY WITH ALL JEA RULES AND POLICIES AS OUTLINED BY THE JEA'S ENVIRONMENTAL RESPONSE COORDINATOR (ERC) AND OTHER ASSOCIATED JEA STANDARDS. THESE SERVICES SHALL INCLUDE, AT A MINIMUM, ASSISTANCE WITH OUTAGE SIMULATIONS, ASSISTANCE WITH THE PREPARATION OF CUSTOMER NOTIFICATION AND OR BOIL WATER NOTICES, DISTRIBUTION OF CUSTOMER NOTIFICATIONS AND COORDINATION WITH ERC AND THE JEA ON-SITE REPRESENTATIVES.
3. CONTRACTOR SHALL REMOVE METER BOX LID AND SET IT NEXT TO THE BOX. THE CONTRACTOR SHALL REPAIR, AT THE CONTRACTORS EXPENSE, ANY DAMAGE TO THE ELECTRONIC NMR/MTU IF DAMAGED DURING THE ABOVE BACTERIOLOGICAL TEST PERIOD AND REMOVED AFTER BACTERIOLOGICAL CLEARANCE.
4. A METER "RESETTER" SHALL BE INSTALLED AND REMOVED AFTER BACTERIOLOGICAL CLEARANCE AS SHOWN. THE RESETTER SHALL INCLUDE AN ANGLED INVERTED KEY METER VALVE ON THE INLET, METER COUPLINGS, 12-INCH RISE AND SIZED TO FIT THE ACTUAL FIELD METER THREADS. ACCEPTABLE: FORD 40 SERIES, MUELLER H-14118 OR JEA APPROVED EQUAL.

TEMPORARY SAMPLE TAP FOR IN-SERVICE MAINS

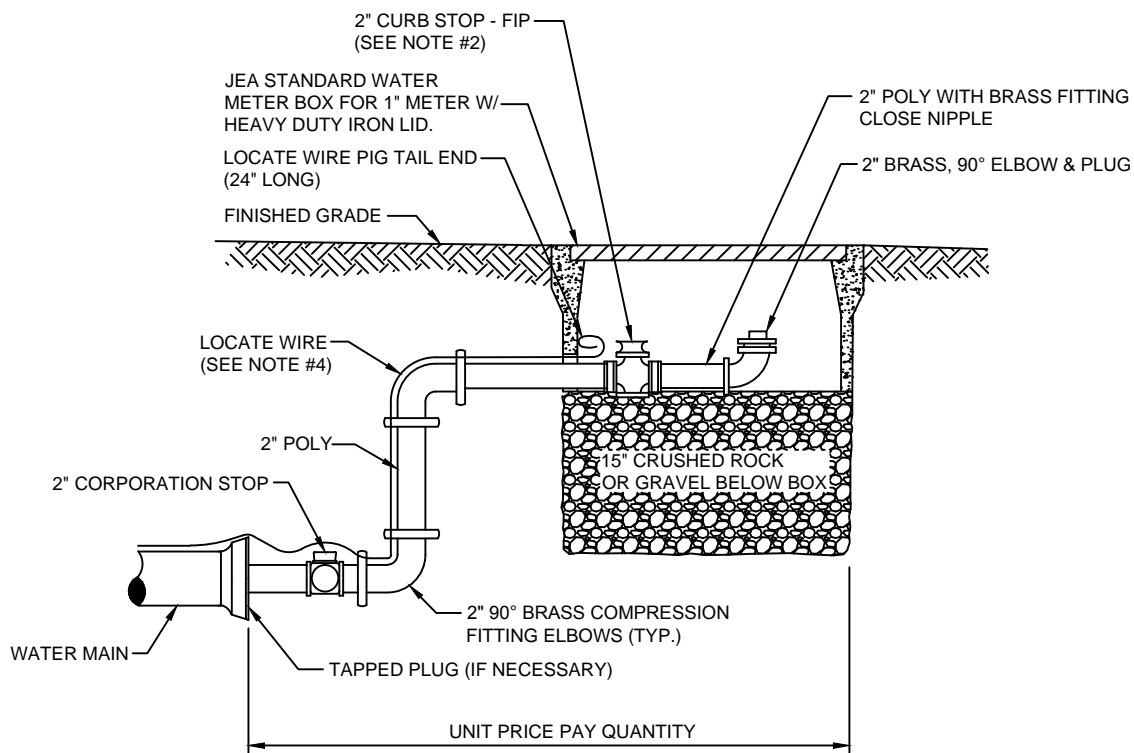

NOTES:

1. PIPE SHALL BE POLYETHYLENE. FITTINGS SHALL BE BRASS.
2. THE 2" CURB STOP SHALL BE ALL BRONZE. FITTINGS SHALL BE BRASS.
3. ANY RECLAIMED WATER VALVE SHALL HAVE RECLAIMED EMBLEM.
4. LOCATE WIRE FOR 10' OR GREATER IN LENGTH.
5. CANNOT BE PLACED UNDER CONCRETE OR PAVEMENT.
6. PLACE 2 FEET PAST LAST WATER MAIN SERVICE CONNECTION.

FLUSHING VALVE BELOW GRADE

W-29
NOT USED

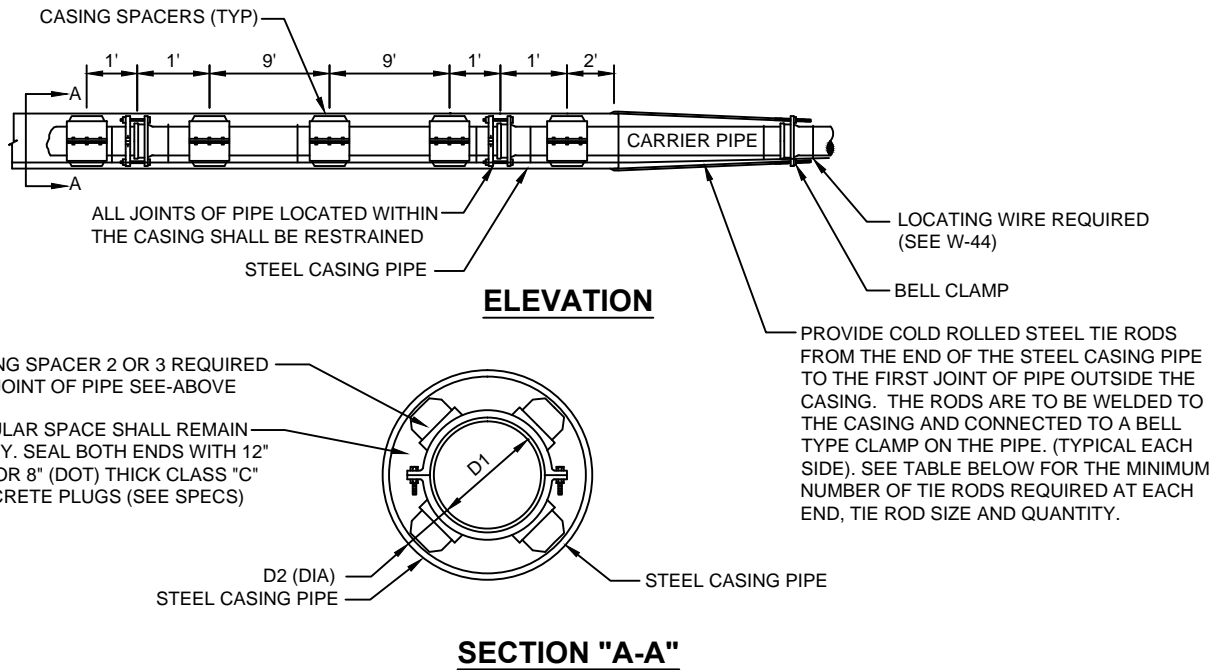

CARRIER TYPE AND CASING PIPE SIZES (MIN) IN INCHES														
CARRIER PIPE NO. DIA. (D ₁)	4	6	8	10	12	14	16	18	20	24	30	36	42	48
CASING PIPE NOM. DIA. (D ₂)	14	16	20	20	24	30	30	30	36	42	48	54	60	66
WALL THICKNESS RAILROAD-(FEC)	0.25	1.25	0.375	0.375	0.375	0.50	0.50	0.50	0.562	0.625	0.625	0.688	0.781	0.781
WALL THICKNESS RAILROAD-(CSX)	0.25	0.281	0.375	0.375	0.375	0.469	0.469	0.469	0.562	0.625	0.688	0.781	0.844	0.938
WALL THICKNESS DOT	0.25	0.25	0.25	0.25	0.25	0.312	0.312	0.312	0.375	0.50	0.50	0.50	0.50	0.50
NUMBER OF TIE RODS (EACH END)	2	2	2	4	4	6	6	8	8	12	14	14	16	16
TIE ROD SIZE (DIA.)	3/4"	3/4"	3/4"	3/4"	3/4"	3/4"	3/4"	3/4"	3/4"	3/4"	1"	1"	1 1/4"	1 1/4"

PIPE MAIN CROSSINGS FOR RAILROADS OR HIGHWAYS

NOTES:

- MIN. COVER TO TOP OF CASING; a) FDOT-3.0' b) RAILROAD-5.5' TO BASE OF RAIL, 4.5' FOR SECONDARY OR INDUSTRIAL TRACKS. EXCEPT FOR F.E.C. (SEE NOTE 3)
- THE INSIDE DIAMETER OF THE CASING PIPE SHALL BE A MINIMUM OF 4 INCHES GREATER THAN THE OUTSIDE DIAMETER OF THE CARRIER PIPE BELL OR COUPLING. HOWEVER, A MINIMUM OF 6 INCHES IS REQUIRED FOR FLORIDA EAST COAST R.R. CROSSINGS.
- THE MINIMUM COVER FOR CASING UNDER FLORIDA EAST COAST RAILROAD SHALL BE 5.0 FEET BELOW THE BOTTOM OF TIES FOR ALL TRACKS.
- ALL JOINTS WITHIN CARRIES PIPE SHALL BE MECHANICAL RESTRAINED JOINTS.
- FOR STREET USES WHICH ARE NOT DOT OR RAILROAD, USE DOT CASING THICKNESS UNLESS OTHERWISE INDICATED BY ENGINEER.
- CASING PIPE SHALL BE FURNISHED IN NOMINAL 8 FOOT LENGTHS (MIN.) UNLESS OTHERWISE INDICATED ON THE DRAWING OR APPROVED BY JEA.
- PIPE TO BE USED AS A CASING SHALL CONFORM TO EITHER ASTM STANDARD A139 FOR "ELECTRIC FUSION (ARC) WELDED STEEL PIPE". WITH A MINIMUM YIELD STRENGTH OF 35,000 PSI OR "API SPECIFICATION API-5LX, GRADE X-42 WELDED STEEL PIPE".

TYPICAL CASING DETAIL - WATER

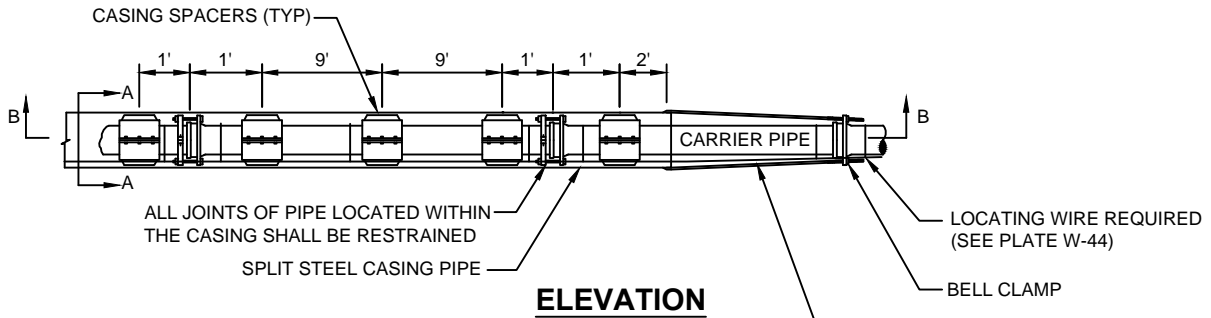

ELEVATION

CASING SPACER 2 OR 3 REQUIRED PER JOINT OF PIPE SEE-ABOVE
 ANNULAR SPACE SHALL REMAIN EMPTY. SEAL BOTH ENDS WITH 12" (RR) OR 8" (DOT) THICK CLASS "C" CONCRETE PLUGS (SEE SPECS)

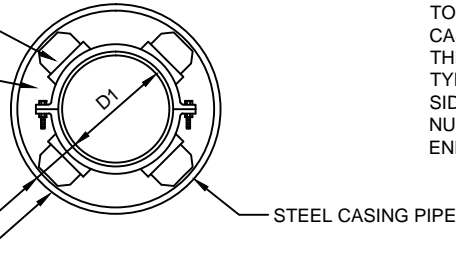

SECTION "A-A"

PROVIDE COLD ROLLED STEEL TIE RODS FROM THE END OF THE STEEL CASING PIPE TO THE FIRST JOINT OF PIPE OUTSIDE THE CASING. THE RODS ARE TO BE WELDED TO THE CASING AND CONNECTED TO A BELL TYPE CLAMP ON THE PIPE. (TYPICAL EACH SIDE). SEE TABLE BELOW FOR THE MINIMUM NUMBER OF TIE RODS REQUIRED AT EACH END, TIE ROD SIZE AND QUANTITY.

CARRIER TYPE AND CASING PIPE SIZES (MIN) IN INCHES														
CARRIER PIPE NO. DIA. (D ₁)	4	6	8	10	12	14	16	18	20	24	30	36	42	48
CASING PIPE NOM. DIA. (D ₂)	14	16	20	20	24	30	30	30	36	42	48	54	60	66
WALL THICKNESS RAILROAD-(FEC)	0.25	1.25	0.375	0.375	0.375	0.50	0.50	0.50	0.562	0.625	0.625	0.688	0.781	0.781
WALL THICKNESS RAILROAD-(CSX)	0.25	0.281	0.375	0.375	0.375	0.469	0.469	0.469	0.562	0.625	0.688	0.781	0.844	0.938
WALL THICKNESS DOT	0.25	0.25	0.25	0.25	0.25	0.312	0.312	0.312	0.375	0.50	0.50	0.50	0.50	0.50
NUMBER OF TIE RODS (EACH END)	2	2	2	4	4	6	6	8	8	12	14	14	16	16
TIE ROD SIZE (DIA.)	3/4"	3/4"	3/4"	3/4"	3/4"	3/4"	3/4"	3/4"	3/4"	3/4"	1"	1"	1 1/4"	1 1/4"

NOTES

1. NOT ALLOWED UNDER RAILROADS.
2. THE INSIDE DIAMETER OF THE CASING PIPE SHALL BE A MINIMUM OF 4 INCHES GREATER THAN THE OUTSIDE DIAMETER OF THE CARRIER PIPE BELL OR COUPLING.
3. ALL JOINTS WITHIN CARRIES PIPE SHALL BE MECHANICAL RESTRAINED JOINTS.
4. FOR STREET USES WHICH ARE NOT DOT OR RAILROAD, USE DOT CASING THICKNESS UNLESS OTHERWISE INDICATED BY ENGINEER.
5. CASING PIPE SHALL BE FURNISHED IN NOMINAL 8 FOOT LENGTHS (MIN.) UNLESS OTHERWISE INDICATED ON THE DRAWING OR APPROVED BY JEA.
6. PIPE TO BE USED AS A CASING SHALL CONFORM TO EITHER ASTM STANDARD A139 FOR "ELECTRIC FUSION (ARC) WELDED STEEL PIPE". WITH A MINIMUM YIELD STRENGTH OF 35,000 PSI OR "API SPECIFICATION API-5LX, GRADE X-42 WELDED STEEL PIPE".

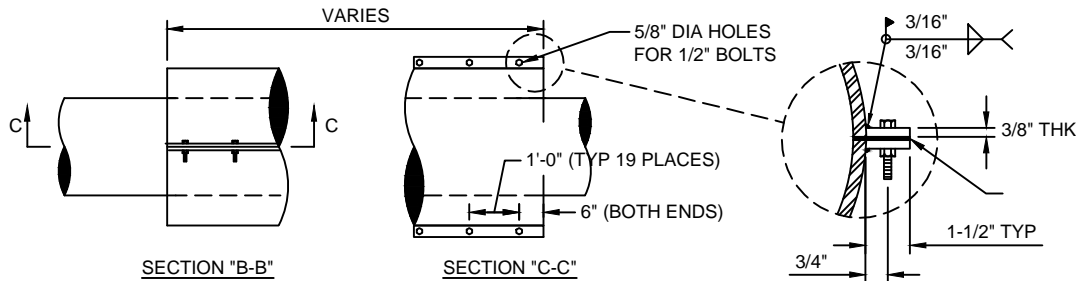

MATERIAL: PIPE - ATSM A53, GRADE B, ERW, STD WALL, CARBON STEEL
 PLATE - STM A36, GRADE B, CARBON STEEL (THICKNESS AS NOTED)
 WELDS ALL WELDS SHALL BE PERFORMED BY A CERTIFIED WELDER
 LININGS/COATINGS: INTERIOR - BARE
 EXTERIOR - BARE

PIPE MAIN FOR CROSSINGS USING SPLIT CASING PIPE
NOT ALLOWED UNDER RAILROADS

TYPICAL SPLIT CASING DETAIL - WATER

PVC PIPE RESTRAINT NOTES:

1. THIS SCHEDULE SHALL BE UTILIZED ON ALL WATER, SEWER FORCE MAIN OR RECLAIMED WATER SYSTEMS. ALL FITTINGS SHALL BE RESTRAINED TO LENGTHS INDICATED ON THE ABOVE SCHEDULE, AT A MINIMUM.
2. ASSUMPTIONS: PVC PIPE, SAFETY FACTOR=1.5, TEST PRESSURE=150PSI, SOIL=GM OR SM, TRENCH TYPE 3, DEPTH OF COVER=30 INCHES FOR 20" AND SMALLER PIPE SIZE OR 36 INCHES FOR 24" AND LARGER PIPE SIZE.
3. BENDS AND VALVES: SHALL BE RESTRAINED ON EACH SIDE OF FITTING.
4. VERTICAL OFFSETS: ARE APPROX. 3 FEET COVER ON TOP AND APPROX. 8 FEET COVER ON BOTTOM; PER THE DETAILS. Lu IS THE RESTRAINED LENGTH FOR THE UPPER (TOP) LEVEL. Li IS THE RESTRAINED LENGTH FOR THE LOWER (DEEPER) LEVEL. ASSUME 45 DEGREE BENDS.
5. TEES: TOTAL LENGTH BETWEEN FIRST JOINTS OR RESTRAINED LENGTH ON EITHER SIDE OF TEE (RUN) SHALL BE A TOTAL DISTANCE OF 30 FEET (MIN). SEE SCHEDULE ABOVE FOR RESTRAINT LENGTH ON TEE "BRANCH" LINE.
6. HDPE TO PVC TRANSITIONS: THE PVC PIPE SIDE SHALL BE RESTRAINED 36 FT (MIN).
7. THE INSTALLATION OF BELL HARNESS RESTRAINTS AT PVC JOINTS (DR-18 & 25 PIPE) SHALL BE COMPLETED PER THE MANUFACTURERS RECOMMENDATION, WHICH INCLUDES NOT OVER TIGHTENING THE PARALLEL RODS/NUTS. THESE NUTS SHOULD ONLY BE SNUG TIGHT. THE HOME MARKS ON THE PIPE SHOULD ALWAYS BE VISIBLE AFTER THE RESTRAINT IS INSTALLED. OVERHOMING THE JOINT MAY CAUSE A FAILURE AT THE BELL RESULTING IN A SERVICE OUTAGE.

LENGTH (L) TO BE RESTRAINED

NOMINAL PIPE SIZE (IN.)	HORIZONTAL BENDS			VERTICAL OFFSETS 45° BENDS (SEE NOTE 4)		VALVES OR DEAD ENDS L (FT.)	
	90° BENDS L (FT.)	45° BENDS L (FT.)	22.5° BENDS L (FT.)	11.25° BENDS L (FT.)			
				UPPER	LOWER		
4	21	9	5	3	17	3	47
6	30	13	6	3	23	4	66
8	38	16	8	4	30	6	86
10	45	19	9	5	36	7	103
12	53	22	11	6	43	8	121
14	61	26	13	6	50	9	140
16	66	28	14	7	55	10	154
18	73	30	15	8	60	11	170
20	79	33	16	8	66	12	186
24	79	33	16	8	77	15	185
30	93	39	19	10	97	17	222
36	106	39	21	11	107	20	257
42	117	49	24	12	120	24	289
48	144	53	26	13	133	26	321

(SEE PLATE Nos. 38C & 38D FOR ADDITIONAL DETAILS)

REDUCERS	TEES SEE NOTE 5		
	SIZE (IN.)	BRANCH SIZE (IN.)	L (FT.)
6x4	34	4	F.O.
8x6	36	6	10
8x4	62	4 < LESS	F.O.
10x8	35	8	29
10x6	63	6 < LESS	F.O.
12x10	36	10	45
12x8	64	8	13
16x12	66	6 < LESS	F.O.
16x10	92	12	62
20x18	35	10	32
20x16	66	8 < LESS	F.O.
20x12	117	16	94
24x20	56	12	39
24x18	80	10	5
24x16	101	10 < LESS	F.O.
30x24	78	20	125
30x20	121	16	76
36x30	78	12	14
36x24	141	10 < LESS	F.O.
42x36	75	24	124
42x30	140	20	104
48x42	75	16	6
48x36	139	16 < LESS	F.O.
		36	36
		30	192
		24	142
		20	83
		16 < LESS	33
		16 < LESS	F.O.
		42	223
		36	178
		30	124
		24	59
		20	5
		16 < LESS	F.O.
		48	253
		42	209
		36	162
		30	104
		24	34
		20 < LESS	F.O.

F.O. = FITTING ONLY

PVC PIPE RESTRAINT JOINT SCHEDULE

PLATE W-31A

JANUARY 2018

LENGTH (L) TO BE RESTRAINED (SEE PLATE Nos. 38C & 38D FOR ADDITIONAL DETAILS)

NOMINAL PIPE SIZE (IN.)	HORIZONTAL BENDS			VERTICAL OFFSETS 45° BENDS (SEE NOTE 4)		VALVES OR DEAD ENDS L (FT.)	
	90° BENDS L (FT.)	45° BENDS L (FT.)	22.5° BENDS L (FT.)	11.25° BENDS L (FT.)	UPPER LOWER L (FT.)		
4	17	7	4	2	11	3	30
6	24	15	5	3	15	4	42
8	31	13	6	3	20	5	55
10	36	15	8	4	23	6	65
12	42	18	9	5	27	7	77
14	48	20	10	5	31	7	87
16	53	22	11	6	35	8	97
18	58	24	12	6	39	9	107
20	63	27	13	6	42	10	118
24	63	27	13	7	49	12	118
30	75	31	15	8	59	14	141
36	86	36	17	9	68	17	163
42	95	40	19	10	76	19	183
48	117	43	21	11	84	21	203

DUCTILE IRON PIPE RESTRAINT NOTES:

1. THIS SCHEDULE SHALL BE UTILIZED ON ALL WATER, SEWER FORCE MAIN OR RECLAIMED WATER SYSTEMS. ALL FITTINGS SHALL BE RESTRAINED TO LENGTHS INDICATED ON THE ABOVE SCHEDULE, AT A MINIMUM.
2. ASSUMPTIONS: DUCTILE IRON PIPE (WITHOUT POLY WRAP), SAFETY FACTOR=1.5, TEST PRESSURE=150PSI, SOIL=GM OR SM, TRENCH TYPE 3, DEPTH OF COVER=30 INCHES FOR 20" AND SMALLER PIPE SIZE OR 36 INCHES FOR 24" AND LARGER PIPE SIZE. FOR D.I.P. W/POLY WRAP, USE RESTRAINT JOINT SCHEDULE FOR PVC PIPE.
3. BENDS AND VALVES: SHALL BE RESTRAINED ON EACH SIDE OF FITTING.
4. VERTICAL OFFSETS: ARE APPROX. 3 FEET COVER ON TOP AND APPROX. 8 FEET COVER ON BOTTOM. PER THE DETAILS, L_u IS THE RESTRAINED LENGTH FOR THE UPPER (TOP) LEVEL. L_l IS THE RESTRAINED LENGTH FOR THE LOWER (DEEPER) LEVEL. ASSUME 45 DEGREE BENDS.
5. TEES: TOTAL LENGTH BETWEEN FIRST JOINTS OR RESTRAINED LENGTH ON EITHER SIDE OF TEE (RUN) SHALL BE A TOTAL DISTANCE OF 30 FEET (MIN). SEE SCHEDULE ABOVE FOR RESTRAINT LENGTH ON TEE "BRANCH" LINE.
6. HDPE TO D.I.P. TRANSITIONS: THE D.I.P. PIPE SIDE SHALL BE RESTRAINED 35 FT. (MIN).

REDUCERS	TEE SEE NOTE 5	
	RUN SIZE (IN.)	BRANCH SIZE (IN.)
6x4	4	4
8x6	4	6
8x4	4	4 < LESS
10x8	8	8
10x6	8	6 < LESS
12x10	10	10
12x8	10	8
16x12	12	12
16x10	12	10
20x18	16	16
20x16	16	12
20x12	16	10
24x20	20	20
24x18	20	16
24x16	20	12
30x24	24	24
30x20	24	20
36x30	30	30
36x24	30	24
42x36	36	36
42x30	36	30
48x42	42	42
48x36	42	36

DUCTILE IRON PIPE RESTRAINT JOINT SCHEDULE
 JANUARY 2018
 PLATE W -31B

F.O. = FITTING ONLY

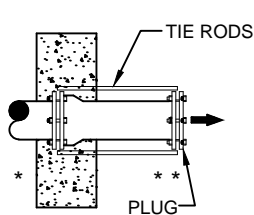
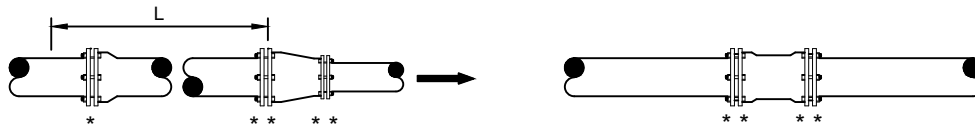
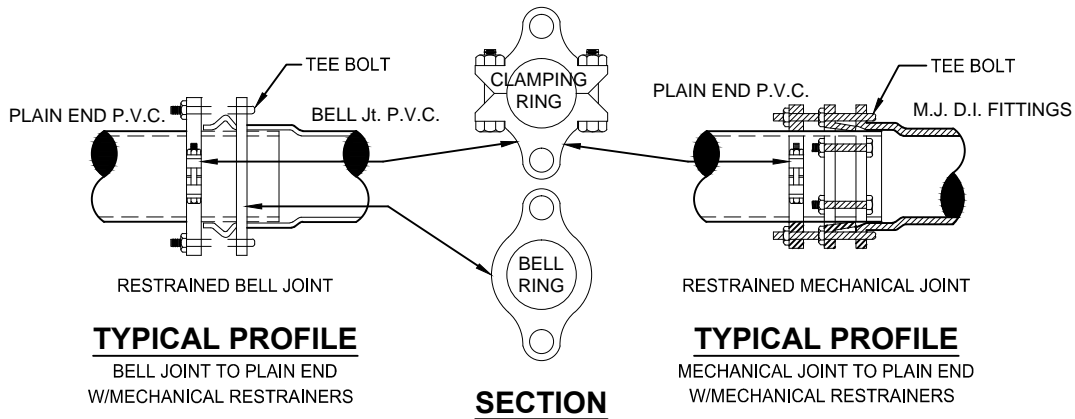

NO. OF TIE RODS REQUIRED

3" - 8"	DIAMETER MAIN - 2 TIE RODS REQUIRED PER JOINT (3/4" ROD)
10" - 12"	DIAMETER MAIN - 4 TIE RODS REQUIRED PER JOINT (3/4" ROD)
14" - 16"	DIAMETER MAIN - 6 TIE RODS REQUIRED PER JOINT (3/4" ROD)
18" - 20"	DIAMETER MAIN - 8 TIE RODS REQUIRED PER JOINT (3/4" ROD)
24"	DIAMETER MAIN - 12 TIE RODS REQUIRED PER JOINT (3/4" ROD)
30" - 36"	DIAMETER MAIN - 14 TIE RODS REQUIRED PER JOINT (1" ROD)
42" - 48"	DIAMETER MAIN - 16 TIE RODS REQUIRED PER JOINT (1 1/4" ROD)
54"	DIAMETER MAIN - 18 TIE RODS REQUIRED PER JOINT (1 1/4" ROD)

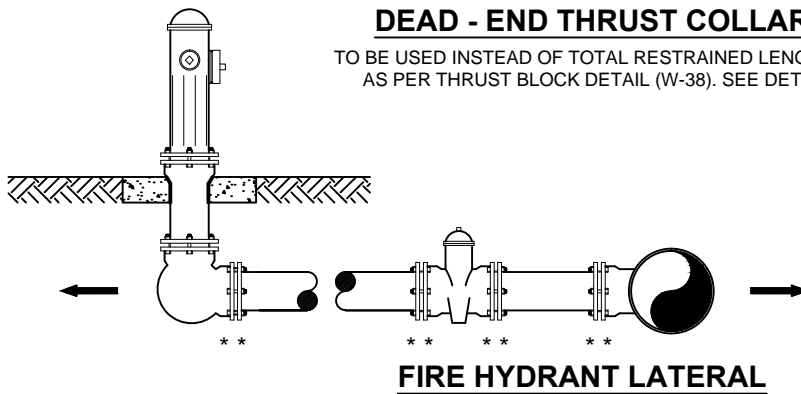

GENERAL NOTE:

1. PAY ITEM " * * " DENOTES A RESTRAINT WHICH IS PAID FOR ON A PER EACH BASIS.
2. PAY ITEM " * * * " DENOTES A RESTRAINT WHICH IS INCLUDED IN THE UNIT PRICE BID FOR FITTING OR VALVE.
3. INDICATES DIRECTION OF THRUST FORCE.

MECHANICAL RESTRAINT DETAILS - I

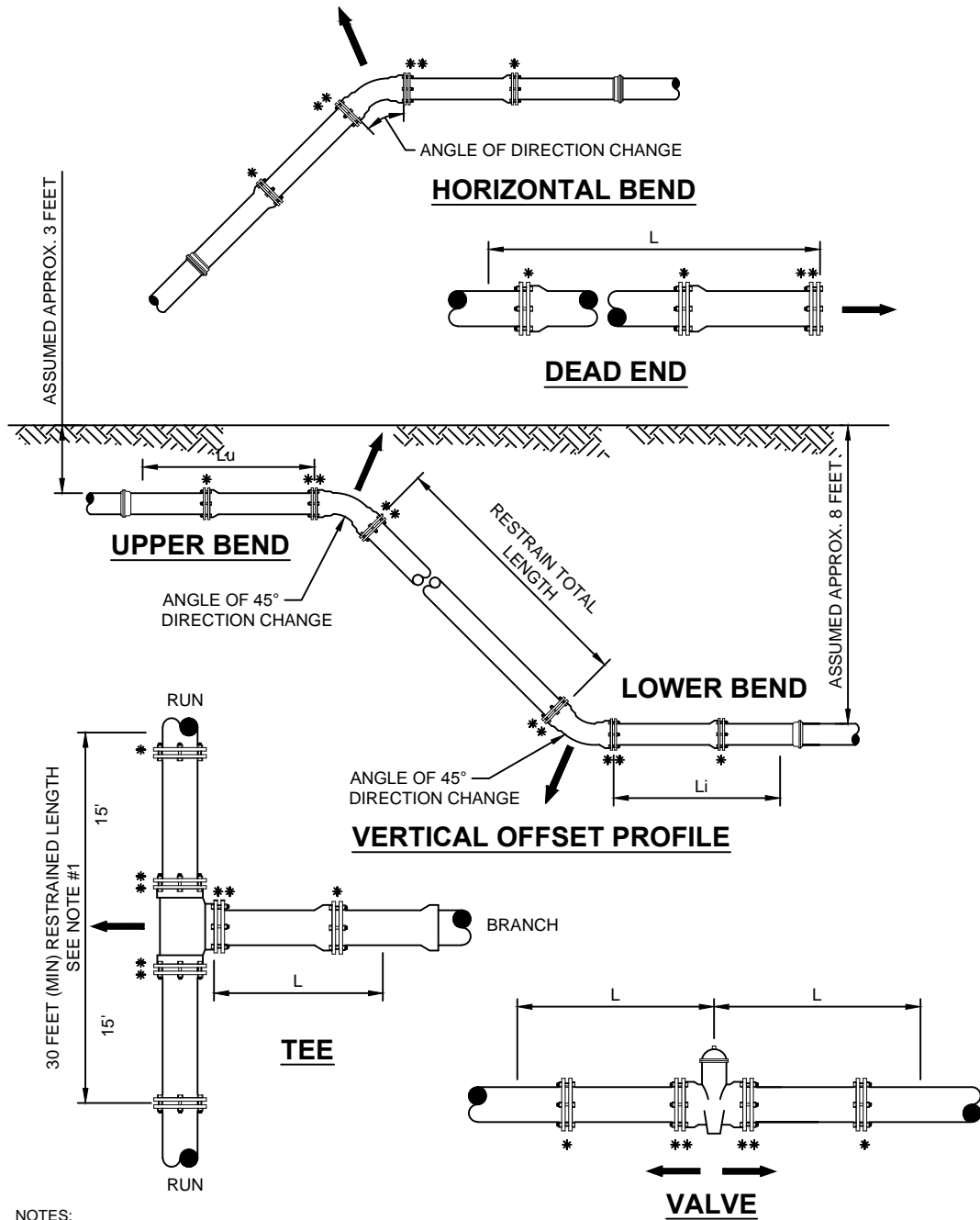

NOTES:

1. TOTAL LENGTH BETWEEN FIRST JOINTS OR RESTRAINED LENGTH ON EITHER SIDE OF TEE (RUN) SHALL BE A TOTAL DISTANCE OF 30 FEET (MIN.).
2. PAY ITEM *** DENOTES A RESTRAINT WHICH IS PAID FOR ON A PER EACH BASIC.
3. PAY ITEM **** DENOTES A RESTRAINT WHICH IS INCLUDED IN THE UNIT PRICE BID FOR FITTING OR VALVE.

MECHANICAL RESTRAINT DETAILS - II

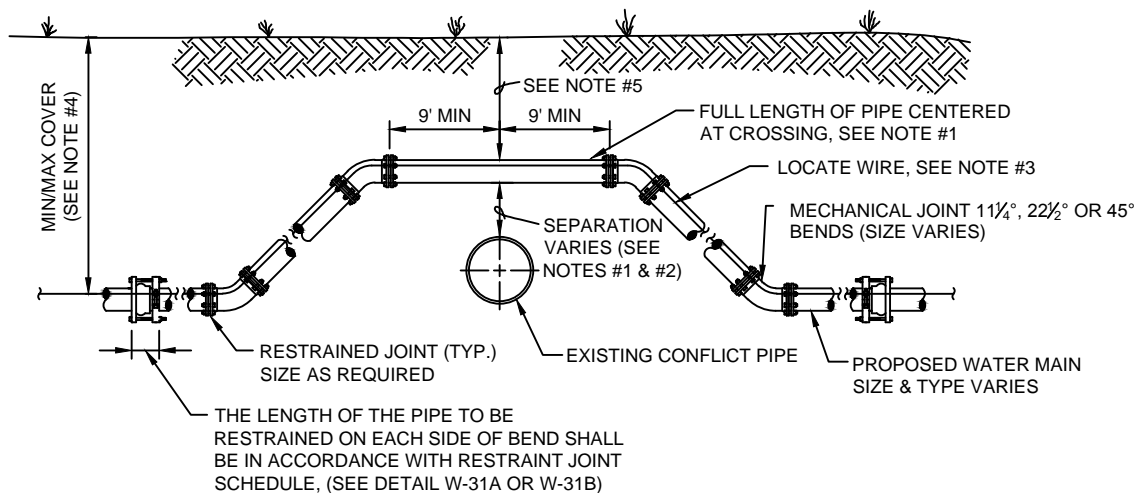

CASE "A" CROSSING

NOTES:

1. THE SOILS BETWEEN THE NEW MAIN AND THE CONFLICT PIPE SHALL BE COMPACTED TO 98% OF THE MAXIMUM DENSITY AS DETERMINED BY THE LABORATORY MODIFIED PROCTOR TEST, ASTM D 1557.
2. FOR MINIMUM VERTICAL SEPARATION REQUIREMENTS SEE DETAIL (W-10 AND W-11).
3. LOCATING WIRE REQUIRED: SEE DETAIL W-44.
4. THE COVER FOR PIPING LESS THAN 24" SIZE SHALL BE 30" (MIN) IN UNPAVED AREAS, 36" (MIN) IN PAVED AREAS AND A MAXIMUM COVER OF 60", UNLESS APPROVED BY JEA. THE COVER FOR PIPING 24" SIZE AND LARGER SHALL BE 36" (MIN) IN PAVED AND UNPAVED AREAS AND A MAXIMUM COVER OF 84", UNLESS APPROVED BY JEA.
5. IF UTILITY CONFLICT IS LOCATED IN A NON-TRAFFIC AREA (NO TRAFFIC LOADS) AND THE NEW PIPE IS D.I.P., THEN THE MINIMUM COVER MAY BE REDUCED TO 24 INCHES (ONLY IN THE AREA OF THE CONFLICT).

ADJUSTMENT OVER EXISTING UTILITIES MECHANICAL RESTRAINTS

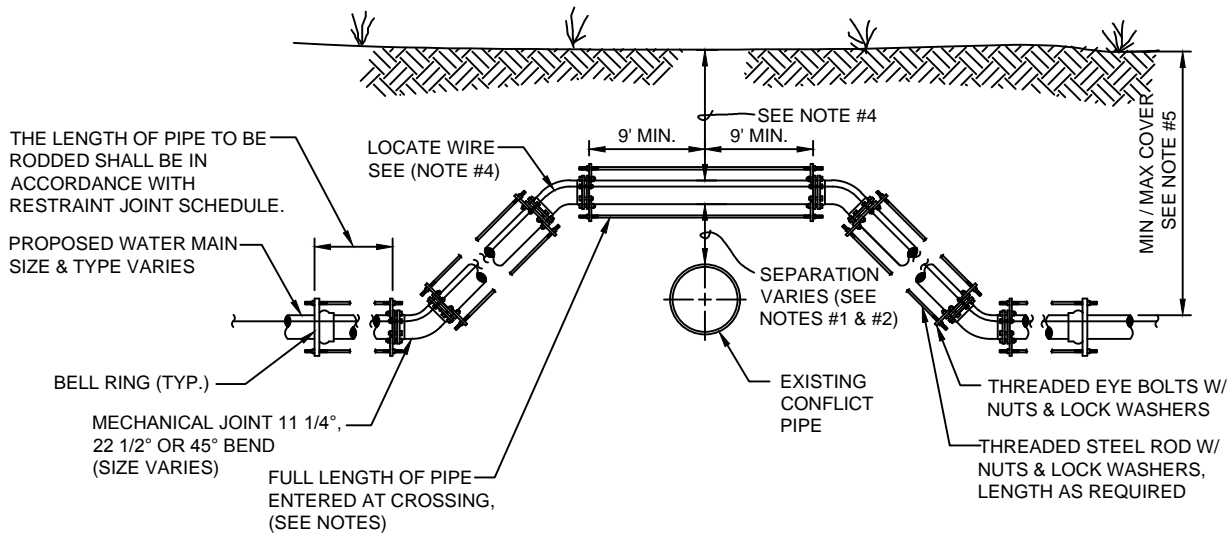

CASE "A" CROSSING

NOTES:

1. IF EXISTING CONFLICT PIPE IS A WATER MAIN 12-INCHES OF SEPARATION IS REQUIRED. A FULL LENGTH OF PIPE SHALL BE CENTERED OVER EXISTING UTILITY MAIN TO PROVIDE MAXIMUM JOINT SPACING FOR ALL CROSSINGS.
2. FOR OTHER LOCATION LIMITATIONS SEE PLATES W-10 & W-11.
3. NUMBER OF TIE RODS REQUIRED IS AS FOLLOWS:

3" - 8"	DIAMETER MAIN - 2 TIE RODS REQUIRED PER JOINT (3/4" ROD)
10" - 12"	DIAMETER MAIN - 4 TIE RODS REQUIRED PER JOINT (3/4" ROD)
14" - 16"	DIAMETER MAIN - 6 TIE RODS REQUIRED PER JOINT (3/4" ROD)
18" - 20"	DIAMETER MAIN - 8 TIE RODS REQUIRED PER JOINT (3/4" ROD)
24"	DIAMETER MAIN - 12 TIE RODS REQUIRED PER JOINT (3/4" ROD)
30" - 36"	DIAMETER MAIN - 14 TIE RODS REQUIRED PER JOINT (1" ROD)
42" - 48"	DIAMETER MAIN - 16 TIE RODS REQUIRED PER JOINT (1 1/4" ROD)
54"	DIAMETER MAIN - 18 TIE RODS REQUIRED PER JOINT (1 1/4" ROD)
4. LOCATING WIRE REQUIRED: SEE PLATE W-44.
5. THE COVER FOR PIPING LESS THAN 24" SIZE SHALL BE 30" (MIN) IN UNPAVED AREAS, 36" (MIN) IN PAVED AREAS AND A MAXIMUM COVER OF 60", UNLESS PRE-APPROVED BY JEA. THE COVER FOR PIPING 24" SIZE AND LARGER SHALL BE 36" (MIN) IN PAVED AND UNPAVED AREAS AND A MAXIMUM COVER OF 84", UNLESS APPROVE BY JEA.
6. THE SOILS BETWEEN THE MAIN AND THE CONFLICT PIPE SHALL BE COMPACTED TO 98% OF THE MAXIMUM DENSITY AS DETERMINED BY THE LABORATORY MODIFIED PROCTOR TEST ASTM D 1557.

ADJUSTMENT OVER EXISTING UTILITIES TIE RODS

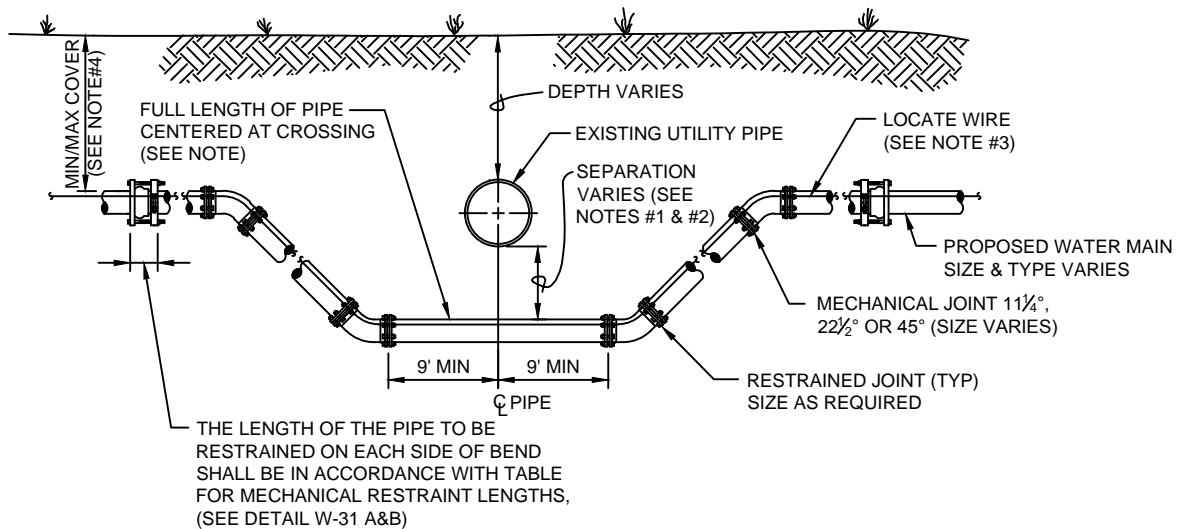

CASE "B" CROSSING

NOTES:

1. THE SOILS BETWEEN THE NEW MAIN AND THE CONFLICT PIPE SHALL BE COMPACTED TO 98% OF THE MAXIMUM DENSITY AS DETERMINED BY THE LABORATORY MODIFIED PROCTOR TEST, ASTM D 1557
2. FOR MINIMUM VERTICAL SEPARATION REQUIREMENTS SEE DETAILS (W-10 AND W-11)
3. LOCATING WIRE REQUIRED: SEE DETAIL W-44.
4. THE COVER FOR PIPING LESS THAN 24" SIZE SHALL BE 30" (MIN) IN UNPAVED AREA, 36" (MIN) IN PAVED AREAS AND A MAXIMUM COVER OF 60", UNLESS APPROVED BY JEA. THE COVER FOR PIPING 24" SIZE AND LARGER SHALL BE 36" (MIN) IN PAVED AND UNPAVED AREAS AND A MAXIMUM COVER OF 84", UNLESS APPROVED BY JEA.

ADJUSTMENT UNDER EXISTING UTILITIES MECHANICAL RESTRAINTS

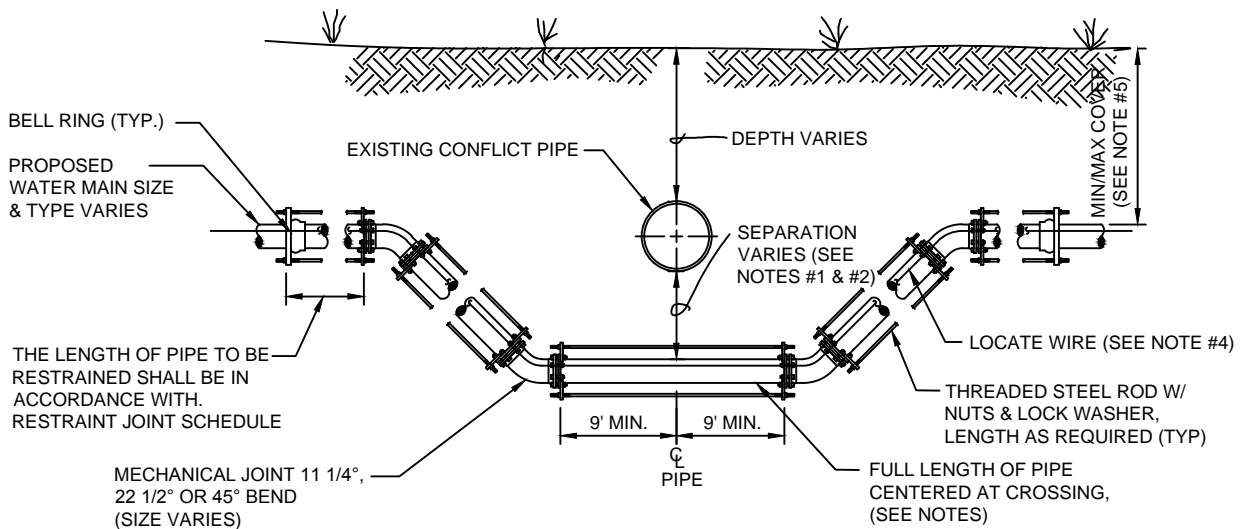

CASE "B" CROSSING

NOTES:

1. IF EXISTING CONFLICT PIPE IS A WATER MAIN, 12-INCHES OF SEPARATION IS REQUIRED. A FULL LENGTH OF PIPE SHALL BE CENTERED OVER EXISTING UTILITY MAIN TO PROVIDE MAXIMUM JOINT SPACING FOR ALL CROSSINGS.
2. FOR OTHER LOCATION LIMITATIONS SEE PLATE W-10 & W-11.
3. NUMBER OF TIE RODS REQUIRED IS AS FOLLOWS:

3" - 8"	DIAMETER MAIN - 2 TIE RODS REQUIRED PER JOINT (3/4" ROD)
10" - 12"	DIAMETER MAIN - 4 TIE RODS REQUIRED PER JOINT (3/4" ROD)
14" - 16"	DIAMETER MAIN - 6 TIE RODS REQUIRED PER JOINT (3/4" ROD)
18" - 20"	DIAMETER MAIN - 8 TIE RODS REQUIRED PER JOINT (3/4" ROD)
24"	DIAMETER MAIN -12 TIE RODS REQUIRED PER JOINT (3/4" ROD)
30" - 36"	DIAMETER MAIN -14 TIE RODS REQUIRED PER JOINT (1" ROD)
42" - 48"	DIAMETER MAIN -16 TIE RODS REQUIRED PER JOINT (1 1/4" ROD)
54"	DIAMETER MAIN -18 TIE RODS REQUIRED PER JOINT (1 1/4" ROD)
4. LOCATING WIRE REQUIRED: SEE PLATE W-44.
5. THE COVER FOR PIPING LESS THAN 24" SIZE SHALL BE 30" (MIN) IN UNPAVED AREAS, 36" (MIN) IN PAVED AREAS AND A MAXIMUM COVER OF 60", UNLESS PRE-APPROVED BY JEA. THE COVER FOR PIPING 24" SIZE AND LARGER SHALL BE 36" (MIN) IN PAVED AND UNPAVED AREAS AND A MAXIMUM COVER OF 84", UNLESS APPROVE BY JEA.
6. THE SOILS BETWEEN THE MAIN AND THE CONFLICT PIPE SHALL BE COMPACTED TO 98% OF THE MAXIMUM DENSITY AS DETERMINED BY THE LABORATORY MODIFIED PROCTOR TEST ASTM D 1557.

ADJUSTMENT UNDER EXISTING UTILITIES TIE RODS

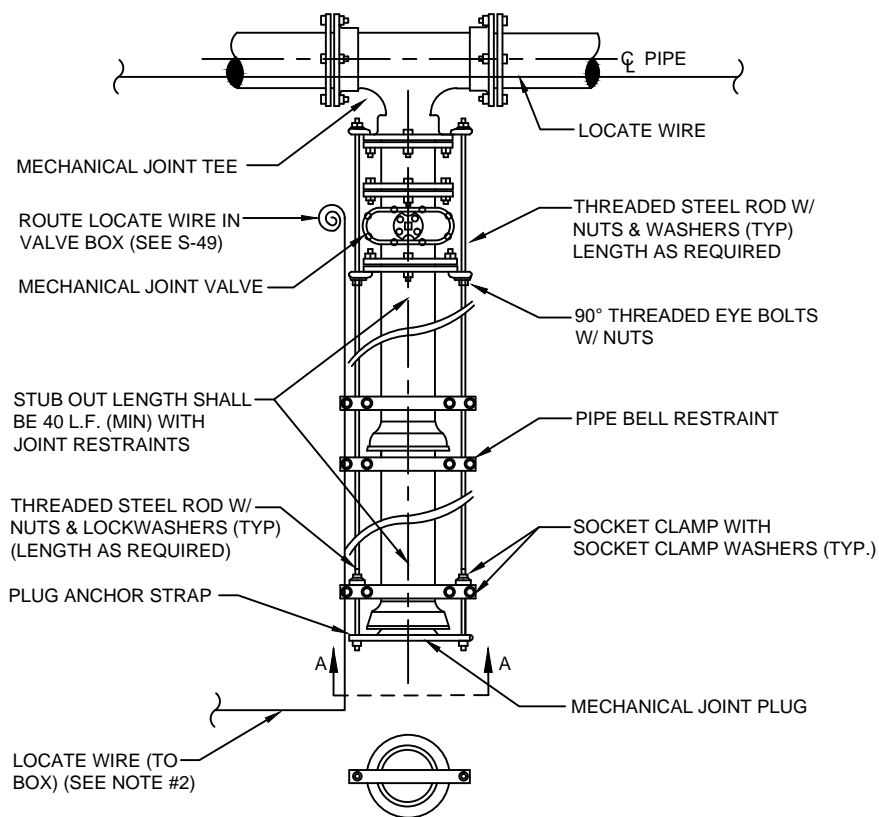

SECTION "A-A"

NOTES:

1. IN LIEU OF BELL/ROD RESTRAINTS, MECHANICAL JOINT RESTRAINTS MAY BE USED.
2. LOCATING WIRE REQUIRED, UTILIZING A LOCATE WIRE BOX INSTALLED AT PLUG LOCATION.
3. NUMBER OF TIE RODS REQUIRED IS AS FOLLOWS:

3" - 8"	DIAMETER MAIN - 2 TIE RODS REQUIRED PER JOINT (3/4" ROD)
10" - 12"	DIAMETER MAIN - 4 TIE RODS REQUIRED PER JOINT (3/4" ROD)
14" - 16"	DIAMETER MAIN - 6 TIE RODS REQUIRED PER JOINT (3/4" ROD)
18" - 20"	DIAMETER MAIN - 8 TIE RODS REQUIRED PER JOINT (3/4" ROD)
24"	DIAMETER MAIN - 12 TIE RODS REQUIRED PER JOINT (3/4" ROD)
30" - 36"	DIAMETER MAIN - 14 TIE RODS REQUIRED PER JOINT (1" ROD)
42" - 48"	DIAMETER MAIN - 16 TIE RODS REQUIRED PER JOINT (1 1/4" ROD)
54"	DIAMETER MAIN - 18 TIE RODS REQUIRED PER JOINT (1 1/4" ROD)
4. THE LOCATION OF THE DEAD END PLUG SHALL NOT BE UNDER PAVEMENT, IF POSSIBLE. THE STUB OUT SHALL EXTEND BEYOND THE INTERSECTION AREAS OR ROAD CROSSING BY 10 FEET (MIN.) WHERE POSSIBLE.

PLUGGED DEAD END USING TIRE RODS

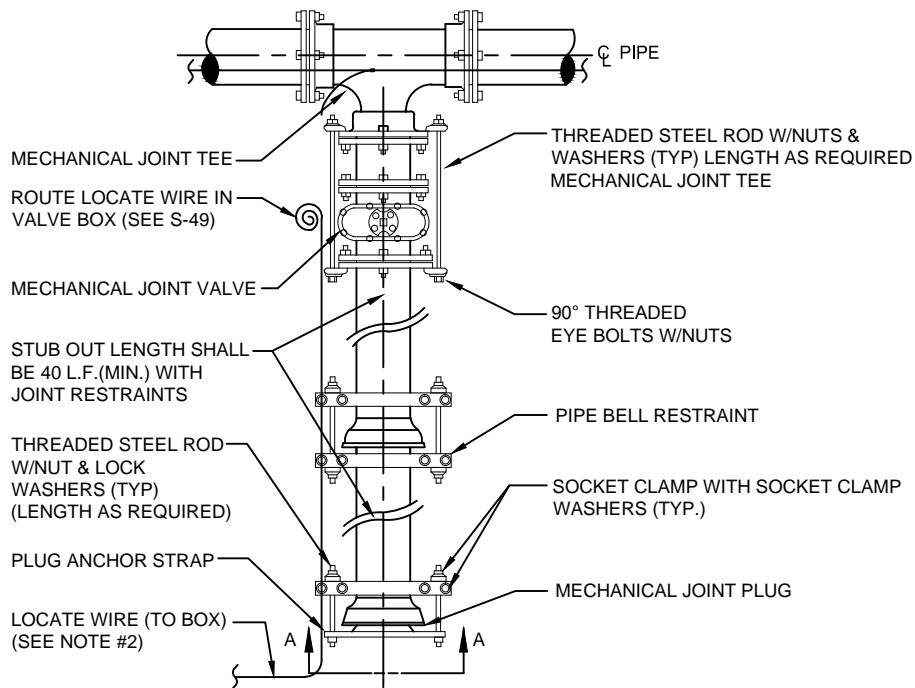

PLAN

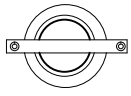

SECTION "A-A"

NOTES:

1. IN LIEU OF BELL/ROD RESTRAINTS, MECHANICAL JOINT RESTRAINTS MAY BE USED.
2. LOCATING WIRE REQUIRED, UTILIZING A LOCATE WIRE BOX INSTALLED AT PLUG LOCATION.
3. NUMBER OF TIE RODS REQUIRED IS AS FOLLOWS:

3" - 8"	DIAMETER MAIN - 2 TIE RODS REQUIRED PER JOINT (3/4" ROD)
10" - 12"	DIAMETER MAIN - 4 TIE RODS REQUIRED PER JOINT (3/4" ROD)
14" - 16"	DIAMETER MAIN - 6 TIE RODS REQUIRED PER JOINT (3/4" ROD)
18" - 20"	DIAMETER MAIN - 8 TIE RODS REQUIRED PER JOINT (3/4" ROD)
24"	DIAMETER MAIN - 12 TIE RODS REQUIRED PER JOINT (3/4" ROD)
30" - 36"	DIAMETER MAIN - 14 TIE RODS REQUIRED PER JOINT (1" ROD)
42" - 48"	DIAMETER MAIN - 16 TIE RODS REQUIRED PER JOINT (1 1/4" ROD)
54"	DIAMETER MAIN - 18 TIE RODS REQUIRED PER JOINT (1 1/4" ROD)
4. THE LOCATION OF THE DEAD END PLUG SHALL NOT BE UNDER PAVEMENT, IF POSSIBLE. THE STUB OUT SHALL EXTEND BEYOND THE INTERSECTION AREAS OR ROAD CROSSING BY 10 FEET (MIN.) WHERE POSSIBLE.

PLUGGED DEAD END USING MECHANICAL RESTRAINTS

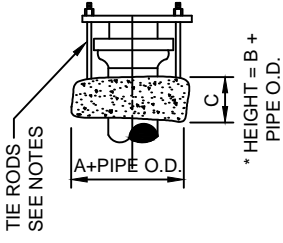
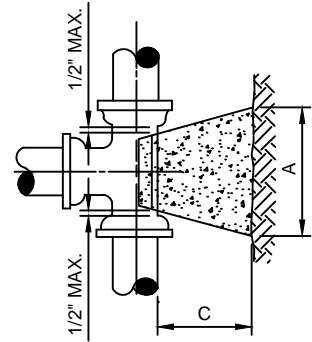

TIE RODS
SEE NOTES

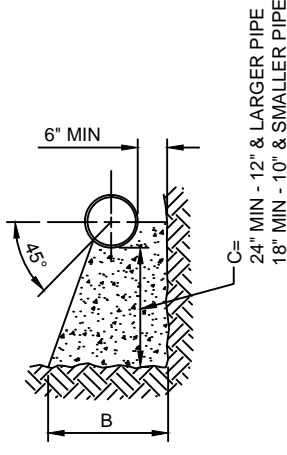

NOTES:

1. ALL BEARING SURFACES TO BE CARRIED TO UNDISTURBED SOIL.
2. THESE TABLES SHOW MINIMUM SIZES FOR THRUST BLOCKS IN GOOD SOIL (A-1 THRU A-3, CLEAN SANDS AND GRAVELS) WITH MINIMUM BEARING CAPACITY OF 2000 PSI.
3. POOR SOILS A-4 THRU A-8, SILTY SOILS, CLAYS, MUCK AND PEAT WILL REQUIRE LARGER THRUST BLOCKING.
4. BOTH CONCRETE THRUST BLOCKS AND TIE RODS MUST BE USED WHEN, IN THE JUDGEMENT OF THE ENGINEER, THE NATURE AND CRITICALITY OF AN INSTALLATION IS SUCH AS TO REQUIRE POSITIVE ASSURANCE OF STABILITY.
5. THE USE OF THRUST BLOCKS SHALL BE LIMITED TO SITUATIONS SUCH AS POINT REPAIR WHERE EXPOSING SEVERAL JOINTS OF PIPE IS NOT FEASIBLE DUE TO EXISTING GROUND CONDITIONS.
6. CONCRETE COLLARS WITH TIE RODS MAY BE USED ON DEAD END LINES AT THE CONTRACTOR'S DISCRETION. NUMBER OF TIE RODS REQUIRED IS AS FOLLOWS:
 DIAMETER MAIN - 2 TIE RODS REQUIRED PER JOINT (3/4" ROD)
 DIAMETER MAIN - 4 TIE RODS REQUIRED PER JOINT (3/4" ROD)
 DIAMETER MAIN - 6 TIE RODS REQUIRED PER JOINT (3/4" ROD)
 DIAMETER MAIN - 8 TIE RODS REQUIRED PER JOINT (3/4" ROD)
 DIAMETER MAIN - 12 TIE RODS REQUIRED PER JOINT (3/4" ROD)
 DIAMETER MAIN - 14 TIE RODS REQUIRED PER JOINT (1" ROD)
 DIAMETER MAIN - 16 TIE RODS REQUIRED PER JOINT (1 1/4" ROD)
 DIAMETER MAIN - 18 TIE RODS REQUIRED PER JOINT (1 1/4" ROD)
7. MAXIMUM TEST PRESSURE TO BE 150 PSI.

THRUST BLOCK FOR TEES & PLUGS

SIZE	90° BEND			S.F. BEARING SURFACE
	A	B	C	
4"	16"	16"	18"	1.78
6"	20"	24"	18"	3.33
8"	26"	32"	18"	5.78
10"	32"	40"	18"	8.89
12"	36"	48"	24"	12.00
14"	40"	56"	24"	15.56
16"	48"	60"	24"	20.00
18"	56"	64"	24"	24.89
20"	60"	76"	24"	31.67
24"	72"	90"	24"	45.00
30"	86"	102"	24"	60.67
36"	116"	108"	24"	86.11

THRUST BLOCK FOR BENDS

SIZE	90° BEND			S.F. BEARING SURFACE	45° BEND			22-1/2° BEND			11-1/4° BEND			S.F. BEARING SURFACE
	A	B	C		A	B	C	A	B	C	A	B	C	
4"	16"	16"	18"	1.78	14"	16"	18"	14"	16"	18"	14"	16"	18"	1.56
6"	22"	32"	18"	4.89	16"	18"	18"	14"	16"	18"	14"	16"	18"	1.56
8"	32"	36"	18"	8.00	24"	28"	18"	16"	18"	18"	14"	16"	18"	2.00
10"	36"	46"	18"	11.50	26"	36"	18"	20"	24"	18"	14"	18"	18"	3.33
12"	44"	56"	24"	17.11	32"	40"	24"	24"	30"	24"	16"	20"	24"	5.00
14"	52"	62"	24"	22.39	36"	48"	24"	26"	36"	24"	20"	24"	24"	6.50
16"	58"	72"	24"	29.00	40"	54"	24"	32"	38"	24"	22"	26"	24"	8.44
18"	64"	80"	24"	35.56	46"	60"	24"	36"	42"	24"	24"	32"	24"	10.50
20"	72"	88"	24"	44.00	52"	66"	24"	38"	48"	24"	26"	36"	24"	12.67
24"	96"	96"	24"	36.89	64"	78"	24"	46"	56"	24"	32"	40"	24"	17.89
30"	122"	102"	24"	86.11	72"	94"	24"	56"	62"	24"	36"	48"	24"	24.11
36"	166"	104"	24"	123.33	88"	108"	24"	64"	78"	24"	44"	54"	24"	34.67
														66.00
														16.50

THRUST BLOCK SIZE CHART

W-39
NOT USED

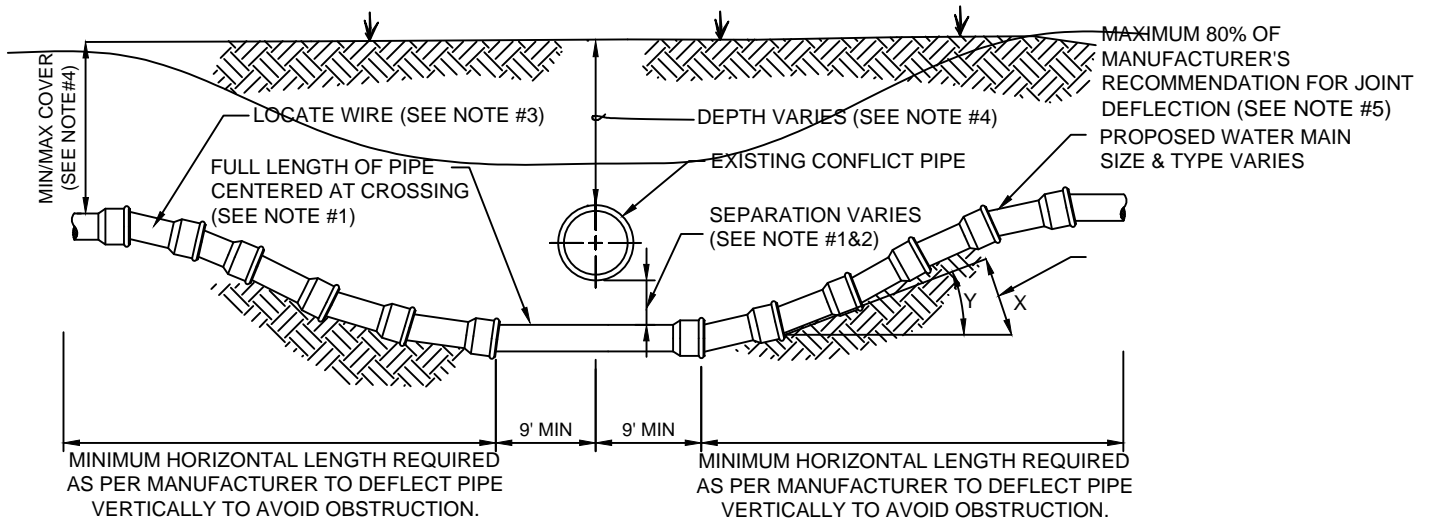

CASE "B" CROSSING

NOTES:

1. IF EXISTING CONFLICT PIPE IS A WATER MAIN, 12-INCHES OF SEPARATION IS REQUIRED. A FULL LENGTH OF PIPE SHALL BE CENTERED OVER EXISTING UTILITY MAIN TO PROVIDE MAXIMUM JOINT SPACING FOR ALL CROSSING.
2. FOR OTHER LOCATION LIMITATIONS SEE DETAIL (W-10 & W-11).
3. LOCATING WIRE REQUIRED: SEE DETAIL W-44.
4. THE COVER OVER ALL PIPING LESS THAN 24" SIZE SHALL BE A MINIMUM OF 30" IN UNPAVED AREAS AND 36" IN PAVED AREAS WITH A MAXIMUM COVER OF 60" UNLESS APPROVED OTHERWISE BY JEA. COVER FOR PIPING 24" SIZE AND LARGER SHALL BE MINIMUM OF 36" (PAVED AND UNPAVED) AND MAXIMUM OF 84" UNLESS APPROVED OTHERWISE BY JEA. THE SOILS BETWEEN THE NEW MAIN AND THE CONFLICT PIPE SHALL BE COMPACTED TO 98% OF THE MAXIMUM DENSITY AS DETERMINED BY THE LABORATORY MODIFIED PROCTOR TEST ASTM D 1557.
5. JEA ONLY ALLOWS 80% OF THE PIPE MANUFACTURER'S RECOMMENDATION FOR JOINT DEFLECTION. BENDING THE PIPE BARREL IS NOT ALLOWED. UNLESS OTHERWISE APPROVED BY JEA, THE MAXIMUM ARE LISTED IN TABLE BELOW. ONLY MANUAL FORCE CAN BE UTILIZED TO OBTAIN THESE JOINT DEFLECTION. ALL OFFSETS ARE BASED ON MINIMUM 20LF PIPE LENGTH.

MAXIMUM ALLOWED OFFSET FOR PIPE BY JOINT DEFLECTION

PVC PIPE

PIPE SIZE (IN.)	(X) MAX. OFFSET (IN.)	(Y) ANGLE AT ONE BELL	RESULTING RADIUS OF CURVE WITH 20FT. LENGTHS
2	30	7°	158 FT
4	10	2.4°	480 FT
6	10	2.4°	480 FT
8	10	2.4°	480 FT
10	10	2.4°	480 FT
12	8.5	2°	564 FT
14 - 24	5	1.2°	960 FT
30 - 48	3.25	0.8°	1477 FT

DUCTILE IRON PIPE (Mechanical Joint)

PIPE SIZE (IN.)	(X) MAX. OFFSET (IN.)	(Y) ANGLE AT ONE BELL	RESULTING RADIUS OF CURVE WITH 20FT. LENGTHS
-	-	-	-
4	27	6.5°	177 FT
6	24	5.7°	200 FT
8 - 12	17.5	4.2°	273 FT
14 - 16	12	2.9°	400 FT
18 - 20	10	2.4°	477 FT
24 - 30	8	1.9°	600 FT
36	7	1.7°	687 FT
42 - 48	6.7	1.6°	716 FT

ADJUSTMENT UNDER EXISTING UTILITIES PIPE JOINT DEFLECTION

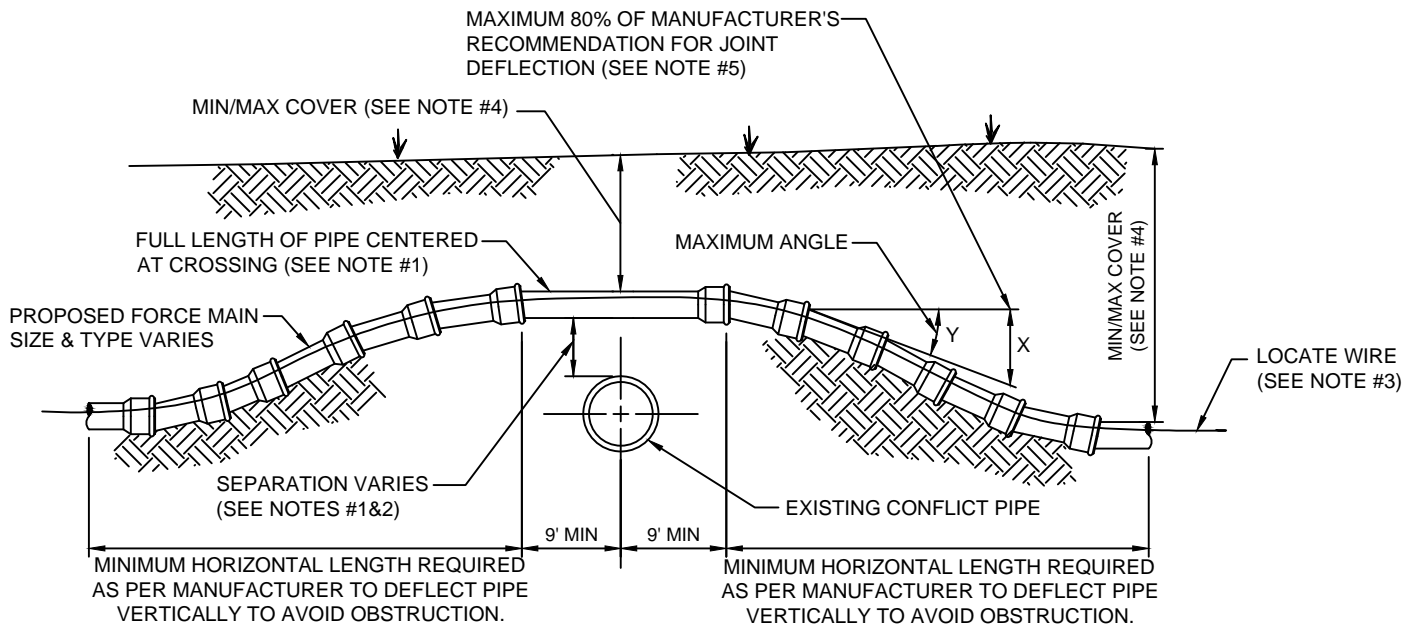

CASE "A" CROSSING

NOTES:

1. IF EXISTING CONFLICT PIPE IS A WATER MAIN, 12-INCHES OF SEPARATION IS REQUIRED. A FULL LENGTH OF PIPE SHALL BE CENTERED OVER EXISTING UTILITY MAIN TO PROVIDE MAXIMUM JOINT SPACING FOR ALL CROSSING.
2. FOR OTHER LOCATION LIMITATIONS SEE DETAIL (W-10 & W-11).
3. LOCATING WIRE REQUIRED: SEE DETAIL W-44.
4. THE COVER OVER ALL PIPING LESS THAN 24" SIZE SHALL BE A MINIMUM OF 30" IN UNPAVED AREAS AND 36" IN PAVED AREAS WITH A MAXIMUM COVER OF 60" UNLESS APPROVED OTHERWISE BY JEA. COVER FOR PIPING 24" SIZE AND LARGER SHALL BE MINIMUM OF 36" (PAVED AND UNPAVED) AND MAXIMUM OF 84" UNLESS APPROVED OTHERWISE BY JEA. THE SOILS BETWEEN THE NEW MAIN AND THE CONFLICT PIPE SHALL BE COMPACTED TO 98% OF THE MAXIMUM DENSITY AS DETERMINED BY THE LABORATORY MODIFIED PROCTOR TEST ASTM D 1557.
5. JEA ONLY ALLOWS 80% OF THE PIPE MANUFACTURER'S RECOMMENDATION FOR JOINT DEFLECTION. BENDING THE PIPE BARREL IS NOT ALLOWED. UNLESS OTHERWISE APPROVED BY JEA, THE MAXIMUM ARE LISTED IN TABLE BELOW. ONLY MANUAL FORCE CAN BE UTILIZED TO OBTAIN THESE JOINT DEFLECTION. ALL OFFSETS ARE BASED ON MINIMUM 20LF PIPE LENGTH.

MAXIMUM ALLOWED OFFSET FOR PIPE BY JOINT DEFLECTION

PVC PIPE

PIPE SIZE (IN.)	(X) MAX. OFFSET (IN.)	(Y) ANGLE AT ONE BELL	RESULTING RADIUS OF CURVE WITH 20FT. LENGTHS
2	30	7°	158 FT
4	10	2.4°	480 FT
6	10	2.4°	480 FT
8	10	2.4°	480 FT
10	10	2.4°	480 FT
12	8.5	2°	564 FT
14 - 24	5	1.2°	960 FT
30 - 48	3.25	0.8°	1477 FT

DUCTILE IRON PIPE (Mechanical Joint)

PIPE SIZE (IN.)	(X) MAX. OFFSET (IN.)	(Y) ANGLE AT ONE BELL	RESULTING RADIUS OF CURVE WITH 20FT. LENGTHS
-	-	-	-
4	27	6.5°	177 FT
6	24	5.7°	200 FT
8 - 12	17.5	4.2°	273 FT
14 - 16	12	2.9°	400 FT
18 - 20	10	2.4°	477 FT
24 - 30	8	1.9°	600 FT
36	7	1.7°	687 FT
42 - 48	6.7	1.6°	716 FT

ADJUSTMENT OVER EXISTING UTILITIES PIPE JOINT DEFLECTION

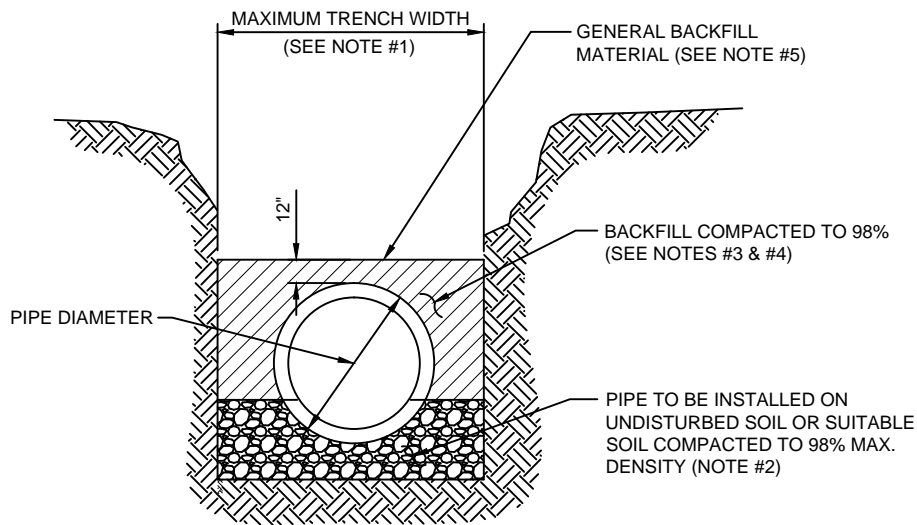

TYPICAL TRENCH

NOTES:

1. TRENCH SIDES SHALL BE APPROXIMATELY VERTICAL BETWEEN AN ELEVATION OF 1 FOOT ABOVE THE TOP OF THE PIPE AND THE CENTER LINE OF THE PIPE; OTHERWISE, TRENCH SIDES SHALL BE AS VERTICAL AS POSSIBLE OR AS REQUIRED BY OSHA STANDARDS. REFER TO THE MEASUREMENT AND PAYMENT SECTION (SECTION #801, PARAGRAPH #4)) TO DETERMINE MAXIMUM PAYLINE WIDTHS.
2. BELL HOLE SHALL BE DUG TO PERMIT THE ENTIRE STRAIGHT BARREL OF THE PIPE TO REST ON THE UNDISTURBED TRENCH BOTTOM. BOULDERS OR LOOSE ROCKS LARGER THAN 3/4 INCH IN SIZE WILL NOT BE PERMITTED IN BACKFILL UP TO 1 FOOT ABOVE THE TOP OF THE PIPE.
3. BACK FILL MATERIAL UP TO A LEVEL OF 1 FOOT OVER THE PIPE SHALL CONSIST OF AASHTO CLASS A-3 SOIL (SUITABLE SOIL) AND SHALL EXCLUDE CLAY MATERIALS AND LOOSE ROCKS LARGER THAN 3/4 INCH SIZE.
4. BACKFILL MATERIAL UP TO A LEVEL 1 FOOT OVER THE TOP OF PIPE OR BOTTOM OF STRUCTURES SHALL BE PLACED IN 6 INCH COMPACTED THICKNESS LAYERS AND SHALL BE COMPACTED TO 98% OF IT'S MAXIMUM DENSITY AS DETERMINED BY THE LABORATORY MODIFIED PROCTOR TEST, ASTM D1557.
5. SEE " EXCAVATION AND EARTHWORK", SECTION 408 FOR ADDITIONAL REQUIREMENTS INCLUDING REMOVAL AND REPLACEMENT OF UNSUITABLE SOILS, DEWATERING, COMPACTION REQUIREMENTS AND DENSITY TESTING OF COMPACTED SOILS.

OPEN CUT TRENCH FOR PRESSURE PIPE

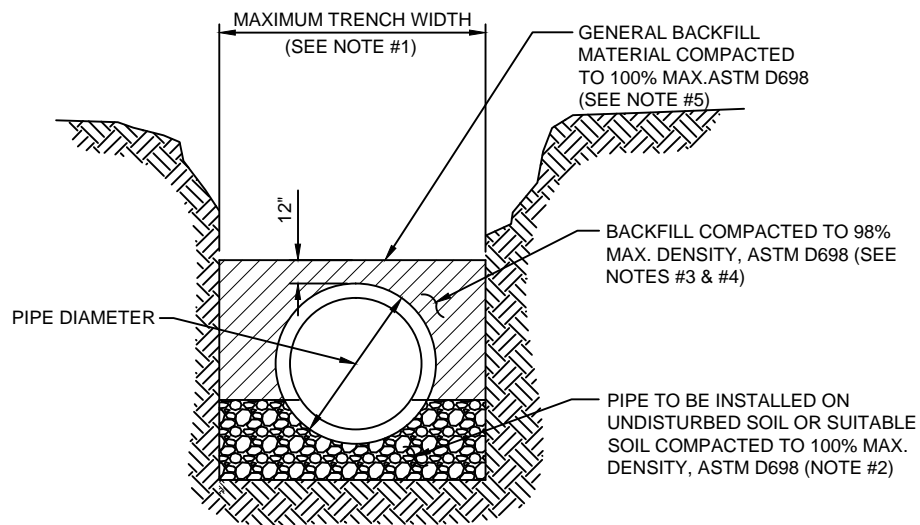

TYPICAL TRENCH

NOTES:

1. TRENCH SIDES SHALL BE APPROXIMATELY VERTICAL BETWEEN AN ELEVATION OF 1 FOOT ABOVE THE TOP OF THE PIPE AND THE CENTER LINE OF THE PIPE; OTHERWISE, TRENCH SIDES SHALL BE AS VERTICAL AS POSSIBLE OR AS REQUIRED BY OSHA STANDARDS. REFER TO THE MEASUREMENT AND PAYMENT SECTION (SECTION #801, PARAGRAPH #4)) TO DETERMINE MAXIMUM PAYLINE WIDTHS.
2. BELL HOLE SHALL BE DUG TO PERMIT THE ENTIRE STRAIGHT BARREL OF THE PIPE TO REST ON THE UNDISTURBED TRENCH BOTTOM. BOULDERS OR LOOSE ROCKS LARGER THAN 3/4 INCH IN SIZE WILL NOT BE PERMITTED IN BACKFILL UP TO 1 FOOT ABOVE THE TOP OF THE PIPE.
3. BACK FILL MATERIAL UP TO A LEVEL OF 1 FOOT OVER THE PIPE SHALL CONSIST OF AASHTO CLASS A-3 SOIL (SUITABLE SOIL) AND SHALL EXCLUDE CLAY MATERIALS AND LOOSE ROCKS LARGER THAN 3/4 INCH SIZE.
4. BACKFILL MATERIAL UP TO A LEVEL 1 FOOT OVER THE TOP OF PIPE OR BOTTOM OF STRUCTURES SHALL BE PLACED IN 6 INCH COMPACTED THICKNESS LAYERS AND SHALL BE COMPACTED TO 100% OF ITS MAXIMUM DENSITY AS DETERMINED BY THE LABORATORY MODIFIED PROCTOR TEST, ASTM D698.
5. SEE " EXCAVATION AND EARTHWORK", SECTION 408 FOR ADDITIONAL REQUIREMENTS AND EXCEPTIONS INCLUDING REMOVAL AND REPLACEMENT OF UNSUITABLE SOILS, DEWATERING, COMPACTION REQUIREMENTS AND DENSITY TESTING OF COMPACTED SOILS.

OPEN CUT TRENCH FOR PRESSURE PIPE

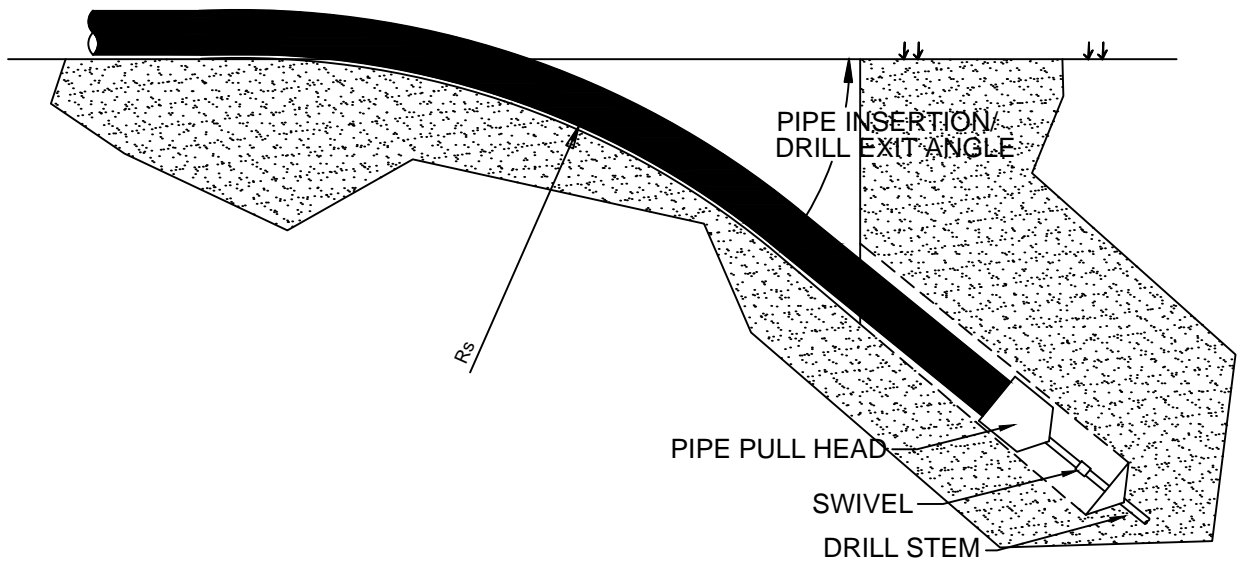

PIPE SIZE	MAXIMUM ALLOWABLE BENDING RADIUS - R_s (FT)	MAXIMUM ALLOWABLE PULLING FORCE (DR18) (K-LBS)
4"	100	10
6"	144	21
8"	189	37
10"	231	56
12"	275	80

**12" AND SMALLER FUSIBLE PVC PIPE
ALLOWABLE BEND RADIUS AND
PULLING FORCE**

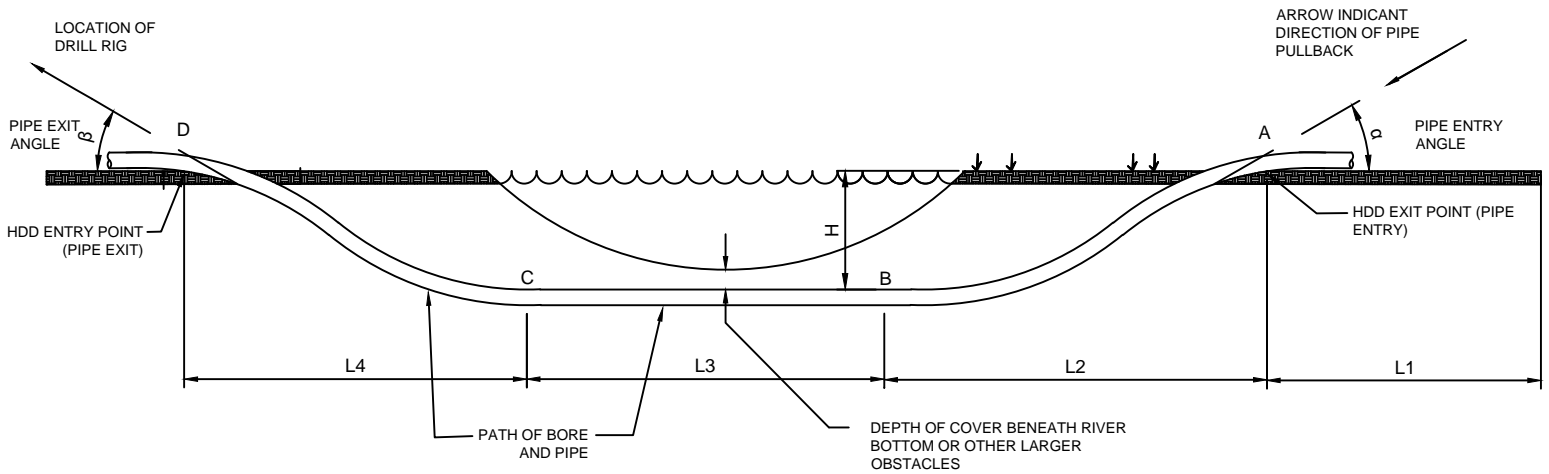
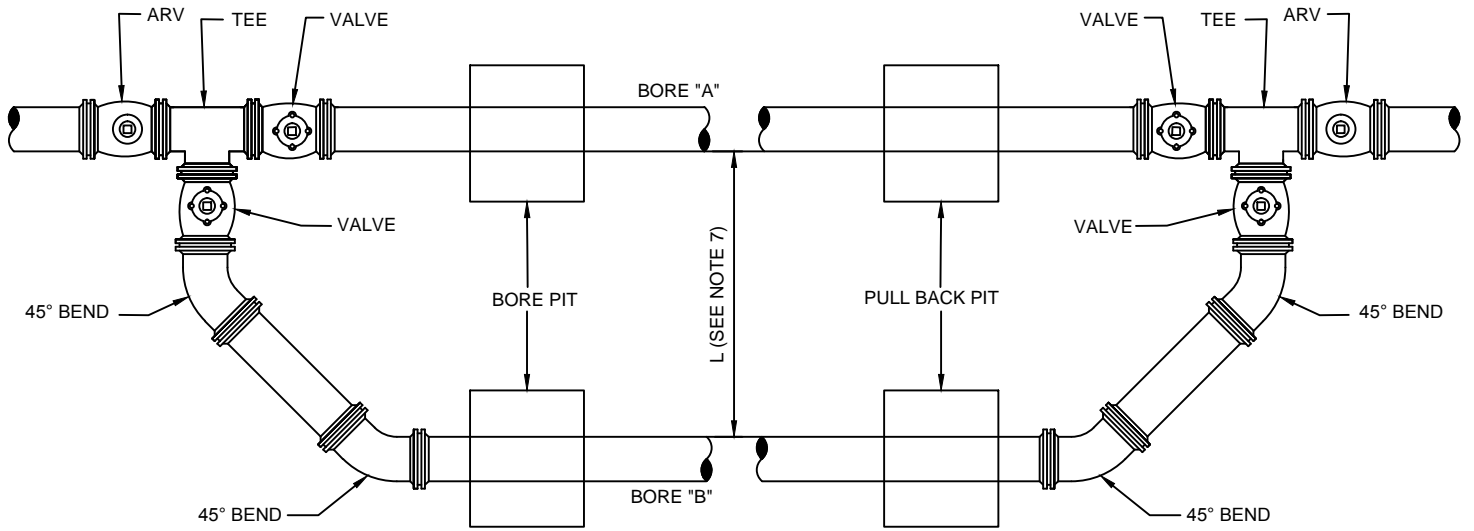

NOTES:

1. POINTS A, B, C, & D PULL FORCE ON PIPE.
2. L1-ADDITIONAL LENGTH OF PIPE REQUIRED FOR HANDLING AND THERMAL CONTRACTION
3. L2-HORIZONTAL DISTANCE TO ACHIEVE DESIRED DEPTH
4. L3-ADDITIONAL DISTANCE TO TRAVERSE AT DESIRED DEPTH
5. L-4 HORIZONTAL DISTANCE TO RISE TO SURFACE
6. H-DEPTH OFF BORE HOLE FROM GROUND SURFACE
7. HORIZONTAL AND VERTICAL DISTANCE BETWEEN BORE "A" TO BORE "B"

DUAL DIRECTIONAL DRILLING

A LOCATE WIRE SHALL BE PLACED ON SERVICES 10FT OR GREATER.

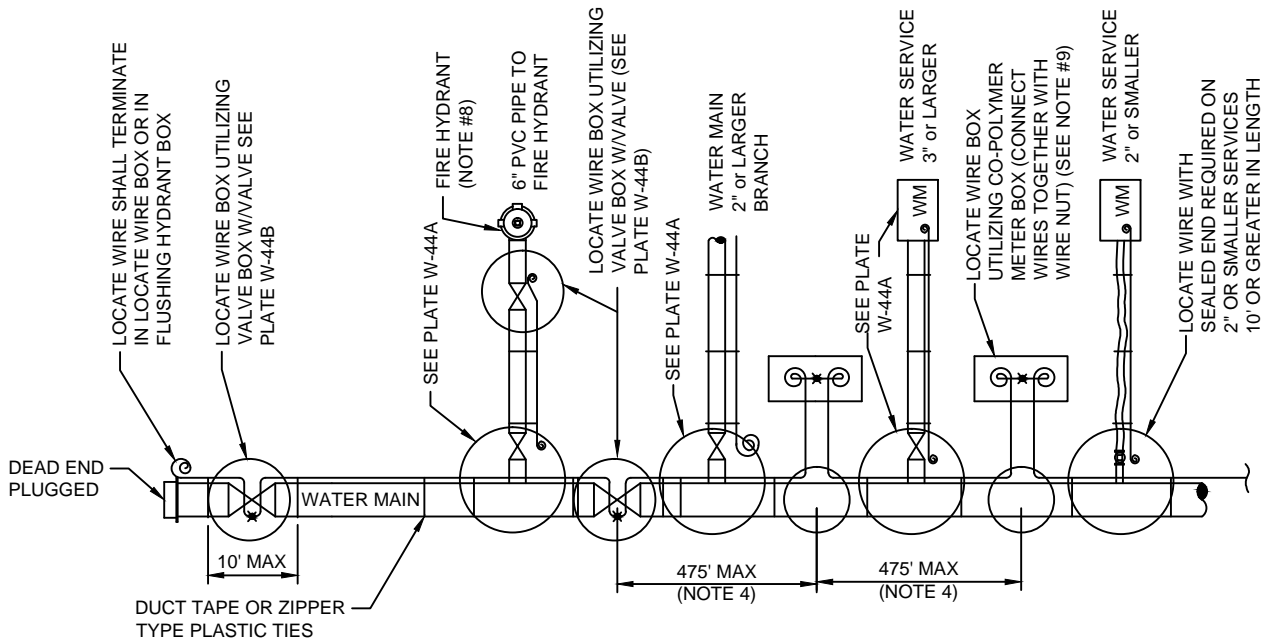

LOCATE WIRE SYSTEM

NOTES:

1. LOCATING WIRE TO BE INSTALLED IN EITHER THE ONE OR ELEVEN O'CLOCK POSITION ON ALL DUCTILE IRON OR PVC (PRESSURE MAINS). LOCATE WIRE SHALL ALSO BE INSTALLED ON ALL (HDPE) POLY MAIN PIPING (1:00 OR 11:00 POSITION, IF POSSIBLE).
2. SECURE LOCATING WIRE TO PVC & D.I.P. WATER MAIN BY USE OF DUCT TAPE OR ZIPPER TYPE PLASTIC TIE STRAPS SPACED AT A MAXIMUM DISTANCE OF TEN (10') AND AT EACH SIDE OF BELL JOINT OR FITTING.
3. THE ENTIRE LOCATING SYSTEM SHALL BE SUBJECTED TO TESTING TO DETERMINE ITS RELIABILITY. WHERE INSTALLED UNDER PAVEMENT AREAS, TESTING SHALL BE DONE PRIOR TO THE PLACEMENT OF PAVEMENT, UNLESS APPROVED OTHERWISE BY JEA.
4. LOCATING WIRE SHALL TERMINATE WITHIN AN ACTIVE VALVE BOX (WITH A VALVE) OR A METER BOX (IF NO VALVE) AT 475' INTERVALS. SEE DETAIL PLATE W-44B. WIRE CONNECTIONS BELOW GROUND (OUTSIDE OF A BOX) SHALL BE AVOIDED.
5. REFER TO SECTION 350 FOR LOCATE WIRE SPECIFICATIONS.
6. "⌘" INDICATES THAT THE WIRES ARE CONNECTED TOGETHER.
7. "⊙" INDICATES A WIRE PIG-TAIL (12" LONG)
8. FOR FIRE HYDRANT LOCATE WIRE REQUIREMENTS AND EXCLUSIONS, SEE PLATES W-12,13 AND 14.
9. AN "LW" CUT SHALL BE CARVED IN THE CONCRETE CURB AND PAINTED AT ALL LOCATE WIRE BOXES.
10. FOUR LANES OF TRAFFIC (HAVING TWO LANES OF TRAFFIC IN EACH DIRECTION) OR GREATER THE LOCATE WIRE SHALL AND VALVE BOX BE OFF-SET TO THE RIGHT-OF-WAY.

LOCATE WIRE CONSTRUCTION FOR WATER MAINS

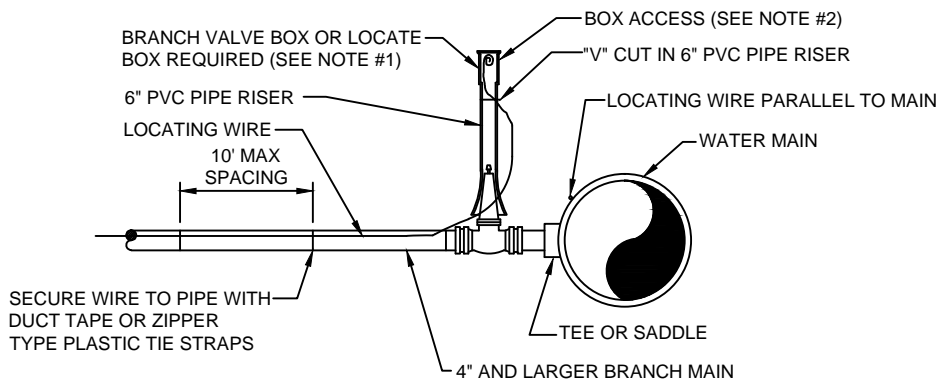

BRANCH FORCE MAIN

(2" AND LARGER WATER MAIN OR 3" AND LARGER WATER SERVICE PIPE)

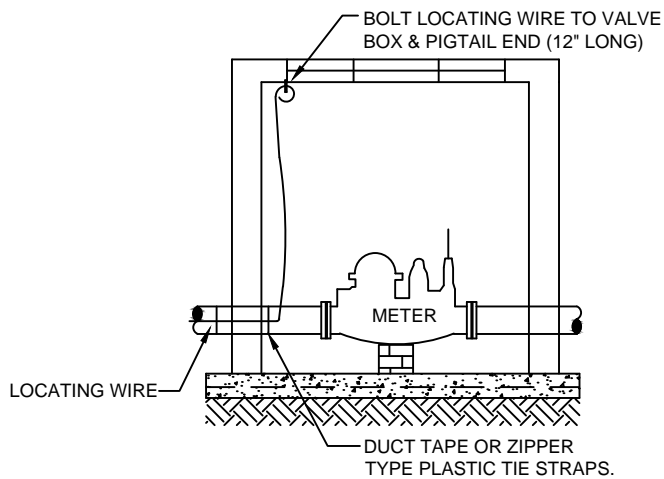

CONNECTION AT LARGE METER BOX

(3" OR LARGER SERVICE)

NOTES:

1. NOTE THAT THE BRANCH WIRE IS NOT CONNECTED TO THE MAIN WIRE.
2. LOCATE WIRE SHALL ENTER THE VALVE BOX THROUGH A "V" CUT IN THE 6" PVC RISER PIPE SECTION (SEE W-18).
3. LOCATE WIRE SHALL HAVE 2' OF SLACK INSIDES VALVE AND LOCATE POINTS.

LOCATE WIRE FOR BRANCH MAIN

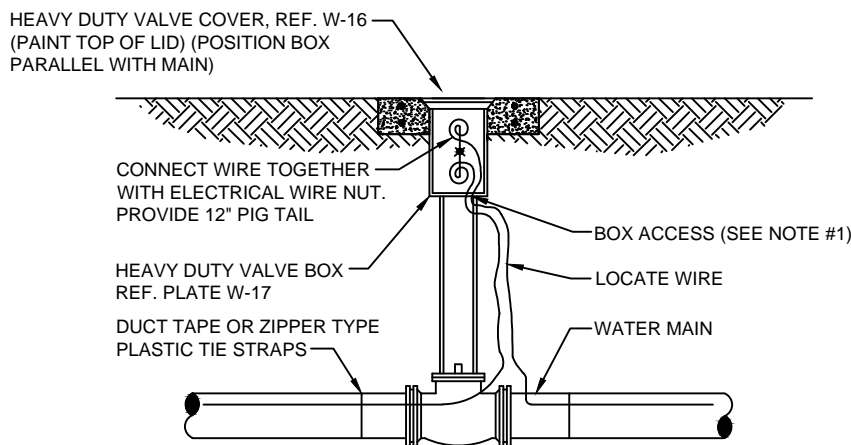

LOCATE WIRE BOX UTILIZING VALVE BOX

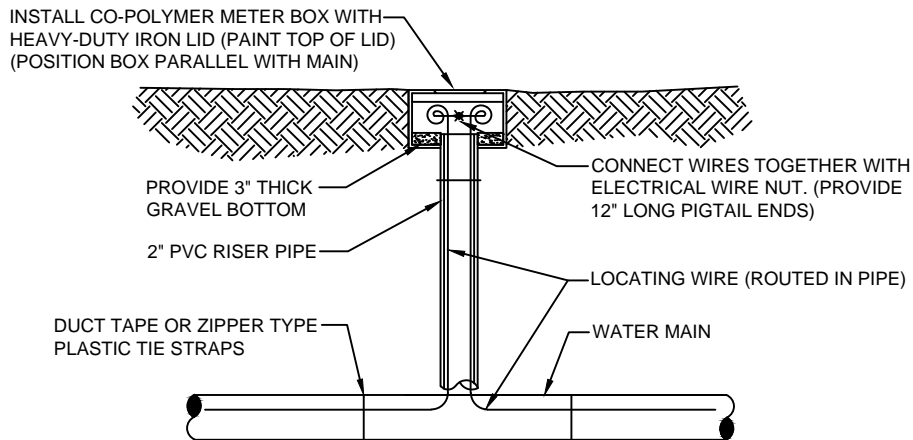

LOCATE WIRE BOX UTILIZING METER BOX

NOTES:

1. LOCATE WIRE SHALL ENTER THE VALVE BOX THROUGH A "V" CUT IN THE 6" PVC RISER PIPE (SEE W-18).
2. LOCATE WIRE SHALL HAVE 2' OF SLACK INSIDES VALVE AND LOCATE POINTS.

LOCATE WIRE BOX

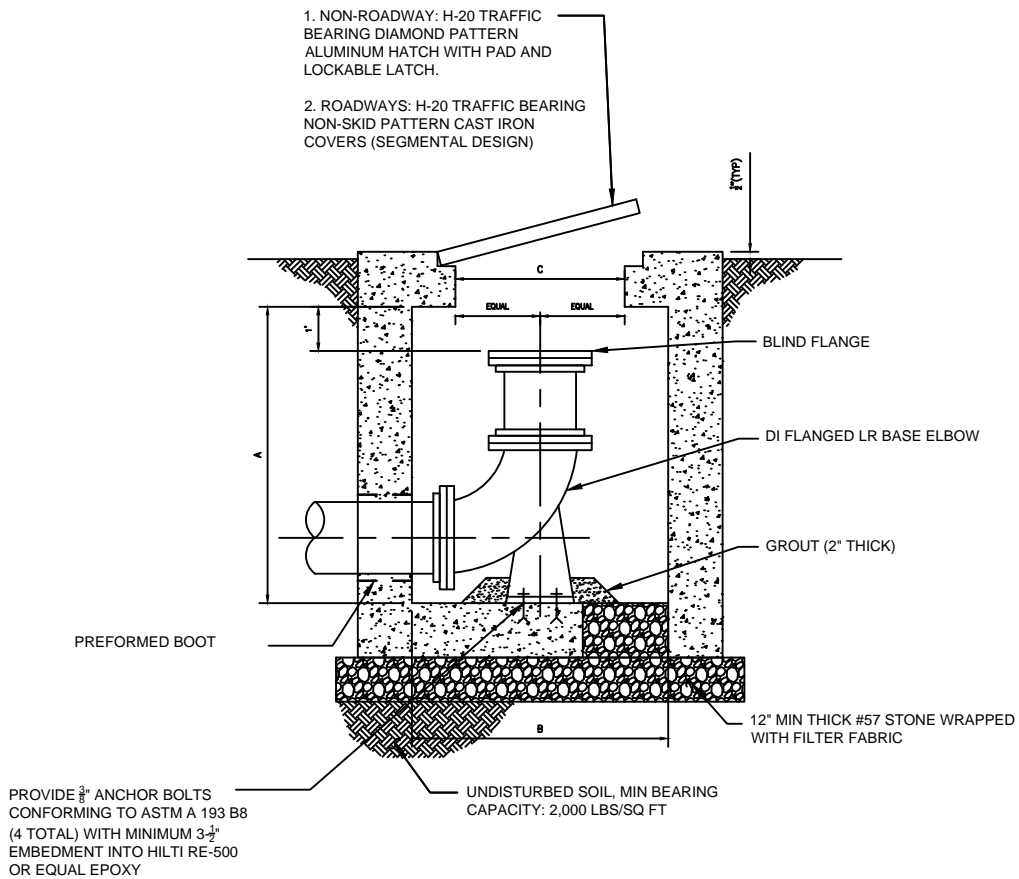

SWABBING PORT AND CLEAN OUT VAULT DETAIL - SECTION

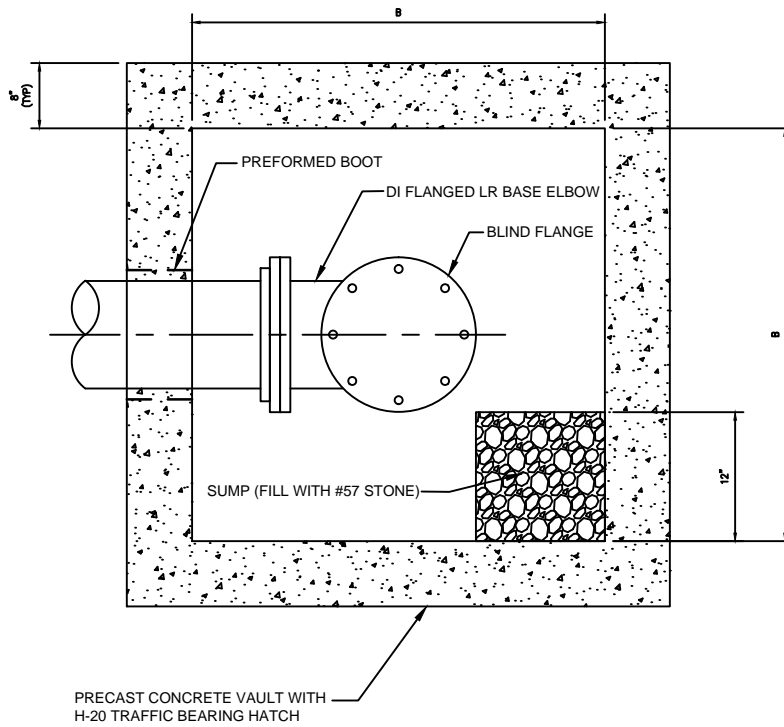

SWABBING PORT AND CLEAN OUT VAULT DETAIL - PLAN

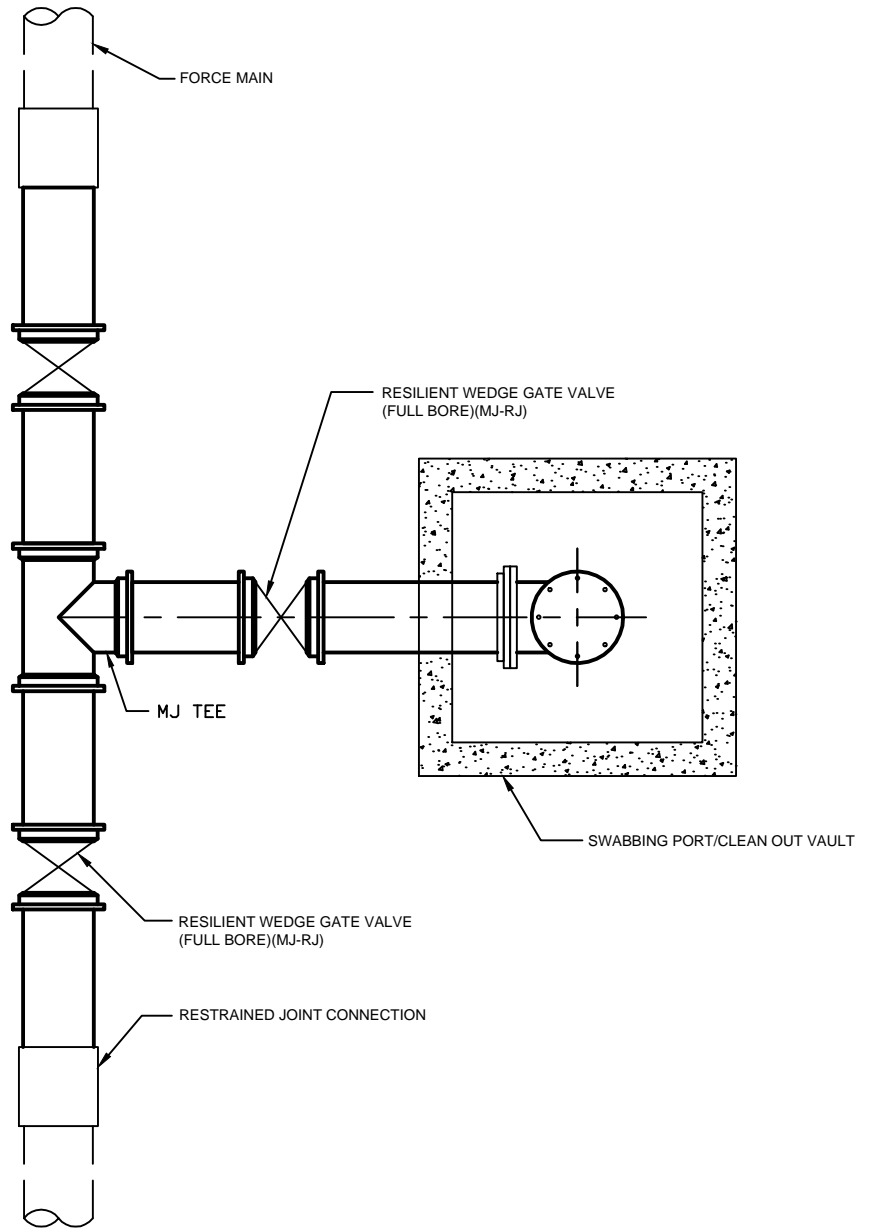

SWABBING LAUNCHING STATION DETAIL FOR NEW FORCE MAIN UP TO 24"

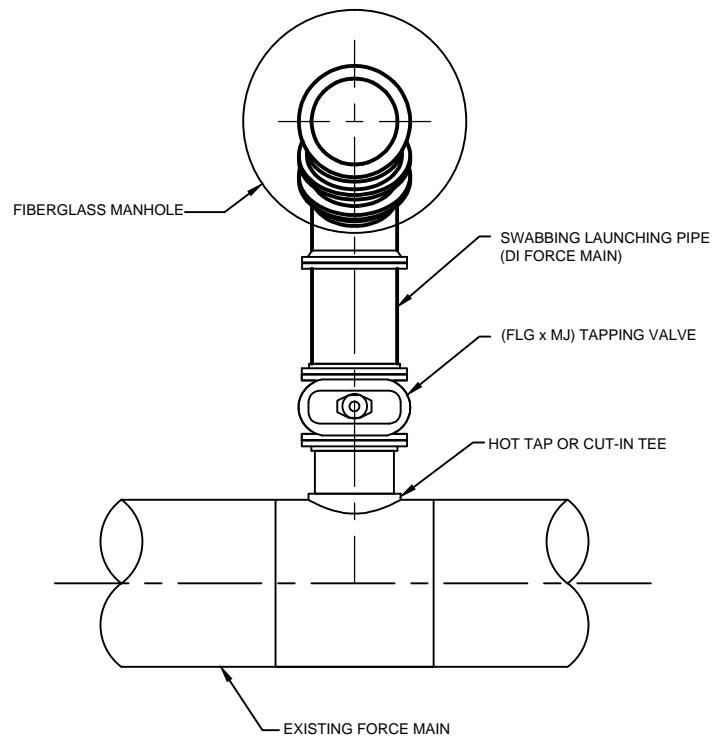

NOTES:

1. FOR HOT TAP CONNECTIONS ON EXISTING FORCE MAINS 10' DIAMETER AND GREATER, DIAMETER OF TAPPING VALVE AND PIG LAUNCHING PIPE SHALL BE ONE NOMINAL SIZE LESS THAN EXISTING FORCE MAIN.

SWABBING PIG LAUNCHING STATION DETAIL FOR FORCE MAINS UP TO 24" - PLAN

