

Welcome to the JEA Awards Meeting

You have been joined to the meeting with your **audio muted** by default.

We will unmute your lines during the public comment time and provide opportunity for you to speak.

During the meeting, interested persons can also email **Halley Stewart** at reimhj@jea.com to submit public comments to be read during the meeting regarding any matter on the agenda for consideration.

Public comments by e-mail must be received no later than 9:00 a.m. to be read during the public comment portion of the meeting.

Please contact **Halley Stewart** by telephone at **(904) 665-8815** or by email at reimhj@jea.com if you experience any technical difficulties during the meeting.

Below is a summary of the meeting controls you will see at the bottom of your screen.

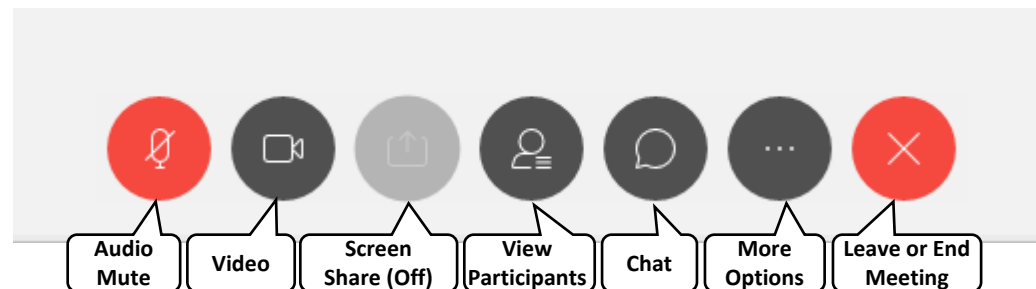

AWARDS COMMITTEE AGENDA

DATE: Thursday, August 25, 2022

TIME: 10:00 A.M.

PLACE: JEA, Customer Center, Bid Office, 1st Floor, 21 West Church Street, Jacksonville, FL32202
OR
WebEx/Teleconference
WebEx Meeting Number (access code): 2309 526 2709
WebEx Password: cQMmJPHA823

Public Comments:

Awards:

1. Approval of the minutes from the last meeting(08/18/2022)
2. 1410795646 - Request approval to award a contract to Prolec-GE Waukesha, Inc. for the supply of 1, 50 MVA transformer for the Nocatee Substation in the amount of \$1,178,233.00, subject to the availability of lawfully approved funds.
3. 1410788446 – Request approval to award a five (5) year contract to Milton J. Wood Fire Protection, Inc. for Fire Extinguisher Services for JEA in the amount of \$704,658.50, subject to the availability of lawfully appropriated funds.
4. **DEFERRED** - Request approval to award a change order to Black & Veatch Management Consulting, LLC for expanded scope of IRP services in the amount of \$452,838.00, for a new not-to-exceed amount of \$2,158,230.00, subject to the availability of lawfully appropriated funds.
5. 1410636046 – Request approval to award contracts to Leidos Engineering LLC \$600,000.00, Power Engineers Inc. \$75,000.00 and Black & Veatch \$75,000.00 for protection and controls engineering services for a total amount of \$750,000.00, subject to the availability of lawfully appropriated funds.
6. Request approval to award a one (1) year contract extension to Corporate Fitness Works, Inc. for the Gym Management Services in the amount of \$106,776.00, for a new not-to-exceed amount of \$406,776.00, subject to the availability of lawfully appropriated funds.
7. Request approval to rescind the Bid and reject all responses to rebid with revised minimum qualifications.
8. **DEFERRED** - 1410653646 – Request approval to award a contract to CDM Smith Inc. for continuing engineering and consulting services for the Integrated Water Resources Management program in the amount of \$25,000,000.00, subject to the availability of lawfully appropriated funds.
9. Request approval to award a piggyback contract to Gate Fleet Services for retail fuel card purchases in the amount of \$16,585,108.22 and to Gate Fuel Services for the purchase of Bulk Fuel Delivery/Diesel Exhaust Fluid (DEF), Terminal Fueling for both diesel and unleaded gasoline, and Temporary Fixed Tanks (Totes) in the amount of \$3,031,312.93, for a NTE amount of \$19,616,421.15, subject to the availability of lawfully appropriated funds.

Informational Items: N/A

Open Discussion: N/A

Public Notice: N/A

General Business: N/A

SPECIAL NOTES: Copies of the above items are available in JEA Procurement, if needed for review. If a person decides to appeal any decision made by the Awards Committee, with respect to any matter considered at this meeting, that person will need a record of the proceedings, and, for such purpose, needs to ensure that a verbatim record of the proceedings is made, which record includes the evidence and testimony upon which the appeal is to be based. If you have a disability that requires reasonable accommodations to participate in the above meeting, please call 665-8625 by 8:30 a.m. the day before the meeting and we will provide reasonable assistance for you.

08-25-2022 Awards Committee

5	REQUEST PROPOSAL (RFP) 7 PROPOSALS	ERIXTON	\$750,000.00	\$600,000.00 \$75,000.00 \$75,000.00	LEIDOS ENGINEERING, LLC POWER ENGINEERS INC BLACK & VEATCH	Term – 3 Years – 2 – 1 Yr Renewals.	<p><u>Engineering Services – Protection and Controls</u></p> <p>This Solicitation is for JEA to obtain General Engineering Services of an experienced engineering firm with technical expertise in engineering generator and transmission Protection and Control (P&C) projects to supplement JEA’s internal design staff (The “Work”). The Work will consist of performing engineering and design services as requested by JEA in support of engineering Generator and Transmission Protection and Control (P&C) projects for which the estimated construction cost as set forth in Florida Statutes Section 287.055, known as the Consultants' Competitive Negotiation Act (CCNA).</p> <p>JEA will award up to three (3) contracts to the three (3) most highly qualified firms that meet the minimum qualifications to submit a proposal and with which JEA is able to successfully negotiate a contract. JEA anticipates needing up to three (3) contracts to meet its future demand for this type of work because JEA may not have the manpower or expertise to handle internally.</p> <p>The proposed engineering rates are compared on an aggregate average basis per firm. When comparing the aggregate average rates index of \$134.55 to the bid index \$144.16, the bid rate average is 7.1% higher and are deemed reasonable. The rates are subject to CPI price adjustment annually with a cap of six percent (6%).</p> <p>1410636046 – Request approval to award contracts to Leidos Engineering LLC (\$600,000.00), Power Engineers Inc. (\$75,000.00) and Black & Veatch (\$75,000.00) for protection and controls engineering services for a total amount of \$750,000.00, subject to the availability of lawfully appropriated funds.</p>
6	CONTRACT EXTENSION	EMANUEL	\$103,668.00	\$106,776.00	CORPORATE FITNESS WORKS, INC.	09/18/2023	<p><u>Gym Management Services</u></p> <p>This request is for a contract extension of the Gym Management Services contract for JEA's employee benefit program. The company shall provide gym management services for JEA fitness facilities located at various JEA sites throughout our service territory. Staffing levels shall include a corporate Manager of Wellness and Fitness Facilities Operations employed by a Gym Management Company to oversee all JEA fitness facilities. In addition to this full-time supervisor position, the Gym Management Company shall provide group exercise instructors and personal trainers as determined by JEA. JEA has approximately two thousand (2000) employees who have the option to pay membership to belong to one (1) or more of the eight (8) JEA gym facilities.</p> <p>This request is for an additional one-year contract extension from 09/19/2022 to 09/18/2023. It was determined to be in JEA’s best interest to extend this contract for one additional year to provide consistency and</p>

08-25-2022 Awards Committee

							<p>assist with the move to our new headquarters. Corporate Fitness Works, Inc. has been instrumental in soliciting and receiving discounts on new equipment purchases for the new gym and the preference was to avoid disruption during the move to the new site. The award amount of \$106,776.00 is based on the monthly fee of \$8,898.00 for the gym management service fee and gym managers salary and benefits. JEA approved a 3% increase in the contract amount for this final year of the contract based on the annual amount of \$103,668.00. The updated pricing has been attached as backup.</p> <p>Request approval to award a one (1) year contract extension to Corporate Fitness Works, Inc. for the Gym Management Services in the amount of \$106,776.00, for a new not-to-exceed amount of \$406,776.00, subject to the availability of lawfully appropriated funds.</p>
7	RESCIND BID	ERIXTON	N/A	N/A	N/A	N/A	<p><u>Design-Build services for 138kv / 230kv Fulton Cut Replacement</u></p> <p>The Company to be Awarded will be comprised of a Contractor and an Engineering firm to perform all engineering, design and construction services needed to replace transmission lattice towers and increase clearances of six (6) existing overhead 138kV and 230kV transmission circuits 840, 918, 926, 934, 935, and 938 across the Fulton Cut near Jax Port in Jacksonville, Florida. Figure 1 below illustrates the project location.</p> <p>Request approval to rescind the Bid and reject all responses to rebid with revised minimum qualifications.</p>
8 - Defer	Defer	Defer	Defer	Defer	Defer	Defer	Defer
9	PIGGYBACK – CITY OF JACKSONVILLE (COJ)	MCELROY	\$19,616,421.15	\$16,585,108.22 \$3,031,312.93	GATE FLEET SERVICES GATE FUEL SERVICES	08/31/2027	<p><u>Joint Agency Fuel Supply Products, Fuel Cards, and Related Services</u></p> <p>The purpose of the City of Jacksonville’s Invitation to Bid SC-0411-22 was to evaluate and select a vendor that can provide fuel supply products, retail fuel cards, and fuel related services at the best value to the City of Jacksonville and participating agencies. The participating agencies are City of Jacksonville (COJ), JEA, Jacksonville Port Authority (JPA), Duval County Public Schools (DCPS) and Jacksonville Airport Authority (JAA). JEA will utilize a variety of services provided by this solicitation to supply fuel for JEA’s fleet of vehicles and equipment. These services include Retail Fuel Card Purchases, Bulk Fuel Delivery/Diesel Exhaust Fluid (DEF), Terminal Fueling for both diesel and unleaded gasoline, and Temporary Fixed Tanks (Totes) during Hurricane season.</p> <p>On July 27, 2022, the City of Jacksonville (COJ) executed Contract SC-0411-22 with Gate Fleet Services as part of a Joint Agency Fuel Supply</p>

08-25-2022 Awards Committee

						<p>Products, Fuel Cards, and Related Services solicitation. Fuel consumption for this solicitation was based on combined historical consumption data provided by each participating agency. This proposed award is to piggyback the award with City of Jacksonville (COJ) to provide fuel related services to JEA Fleet Services.</p> <p>JEA Fleet Services over the last five (5) plus years has developed an optimized fuel strategy to best serve JEA's needs to allow flexibility as our service model evolves. Those areas are:</p> <ol style="list-style-type: none">1. After hours diesel wet hose fueling and DEF at service centers, provided by Jacobus;2. COJ pump fueling locations, COJ purchases the fuel from Gate, JEA purchases from COJ;3. Wet hose fueling of off-road equipment and generators using terminal loaded JEA fuel trucks, fuel purchased from Gate;4. Vehicle operator purchases using Fleet Fuel cards at retail pump locations located throughout the JEA service territory, fuel and DEF purchased from Gate;5. Temporary fixed tanks rentals during Hurricane season to ensure fuel is available to the JEA Fleet if there is infrastructure damage following a storm, fuel purchases from Gate. <p>This contract will support JEA's Fleet Service's terminal fueling, retail fueling, and bulk fueling services noted in items 3 – 5 along with an indirect impact to the COJ pump purchases as COJ depends on the same Gate Contract for fuel.</p> <p>When comparing bid pricing to the previous contract, both are consistent in using OPIS rack rate pricing with a set mark-up, plus appropriate taxes. The mark-up per gallon increased from .0583 per gallon for all grades on the existing contract, to .079 per gallon for non-diesel grades and to .089 per gallon markup for diesel grades under this contract. The budget estimate and actual award amounts are based on Fleet's average annual consumption using the current mark-up amounts. Due to inflated OPIS rates over the past six months Fleet Services is projected to be overbudget for FY22 and FY23 if the rates continue to remain high. Fleet Services has identified a line within the budget to cover these overages.</p> <p>Request approval to award a piggyback contract to Gate Fleet Services for retail fuel card purchases in the amount of \$16,585,108.22 and to Gate</p>
--	--	--	--	--	--	--

08-25-2022 Awards Committee

							Fuel Services for the purchase of Bulk Fuel Delivery/Diesel Exhaust Fluid (DEF), Terminal Fueling for both diesel and unleaded gasoline, and Temporary Fixed Tanks (Totes) in the amount of \$3,031,312.93, for a NTE amount of \$19,616,421.15, subject to the availability of lawfully appropriated funds.
Total Award				\$22,356,088.65			

JEA AWARDS COMMITTEE

AUGUST 18, 2022, MEETING MINUTES

The JEA procurement Awards Committee met on AUGUST 18, 2022, in person with a WebEx option.

WebEx Meeting Number (access code): 2309 526 2709

WebEx Password: cQMmJPHA823

Members in attendance were Jenny McCollum as Chief Procurement Officer, Stephen Datz Chairperson (onsite), Jackie Scheel for Hai Vu (onsite) as Vice Chairperson, Laure Whitmer as Budget Representative, Regina Ross as Office of General Counsel Representative; Gabor Acs for Ricky Erixton, Mark Stultz for Laura Schepis and Joe Orfano (onsite). Unless otherwise indicated, all attendees were via WebEx.

Chair Datz called the meeting to order at 10:00 a.m., introduced the Awards Committee Members, and confirmed that there was an in-person quorum of the Committee membership present.

Public Comments:

Chair Datz recognized the public comment speaking period and opened the meeting floor to public comments. No public comments were provided by email, phone or videoconference.

Awards:

1. Approval of the minutes from the last meeting (08/11/2022). Chair Datz verbally presented the Committee Members the proposed August 11, 2022, minutes as presented.

MOTION: Joe Orfano made a motion to approve the August 11, 2022, minutes (Award Item 1). The motion was seconded by Jackie Scheel and approved unanimously by the Awards Committee (5-0).

The Committee Members reviewed and discussed the following Awards Items 2 – 9:

2. 1410613646 – Request approval to award a contract for engineering services for the Deerwood WTP - Well No. 2 Replacement to CDM Smith Inc. in the amount of \$496,627.00, subject to the availability of lawfully appropriated funds.

MOTION: Mark Stultz made a motion to approve Award Item 2 as presented in the committee packet. The motion was seconded by Joe Orfano and approved unanimously by the Awards Committee (5-0).

3. Request approval to terminate the contract with Summit Fire & Security LLC for electric plant fire protection services and suspend bidding privileges for two (2) years.

MOTION: Jackie Scheel made a motion to approve Award Item 3 as presented in the committee packet. The motion was seconded by Joe Orfano and approved unanimously by the Awards Committee (5-0).

4. Request approval to award a contract renewal to WG Yates & Sons Construction Co. & Sons Construction Co. in the amount of \$3,875,000.00 and to WW Gay Mechanical Contractors, Inc. in the amount of \$3,875,000.00 for general construction services for JEA, for a new total not-to-exceed amount of \$54,424,000.00, subject to the availability of lawfully approved funds.

MOTION: Mark Stultz made a motion to approve Award Item 4 as presented in the committee packet. The motion was seconded by Jackie Scheel and approved unanimously by the Awards Committee (5-0).

5. Request approval to award a piggyback/ratification contract to Bozard Ford Company for the purchase of twenty-four (24) vehicles within the vehicle class categories of 117, 117C, and 117X (Ford F-150 4X4 Trucks) for FY23, in the amount of \$1,332,458.00, subject to the availability of lawfully appropriated funds.

MOTION: Joe Orfano made a motion to approve Award Item 5 as amended in the committee packet. The motion was seconded by Gabor Acs and approved unanimously by the Awards Committee (5-0).

6. Request approval to award a contract amendment with Duval Ford for the purchase of twenty-nine (29) vehicle class categories 116, 116C and 117X (Ford F 150 4X2 Trucks) for FY23 in the amount of \$1,270,918.46, for a total not-to-exceed amount of \$4,872,799.46, subject to the availability of lawfully appropriated funds.

MOTION: Joe Orfano made a motion to approve Award Item 5 as amended in the committee packet. The motion was seconded by Mark Stultz and approved unanimously by the Awards Committee (5-0).

7. 1410797646 - Request approval to award a contract to Equipment Services of Jacksonville, Inc. for JEA Trailer Maintenance and Repair services in the amount of \$448,605.49, subject to the availability of lawfully appropriated funds.

MOTION: Jackie Scheel made a motion to approve Award Item 5 as amended in the committee packet. The motion was seconded by Mark Stultz and approved unanimously by the Awards Committee (5-0).

8. RFQ 103707– Request approval to award a contract to G&W Electric Company for the purchase of six (6) SWEPA023 switches for a total amount of \$699,972.00 subject to the availability of lawfully appropriated funds.

MOTION: Joe Orfano made a motion to approve Award Item 5 as amended in the committee packet. The motion was seconded by Mark Stultz and approved unanimously by the Awards Committee (5-0).

9. Request approval to award a contract increase to Perdue, Inc. for furniture procurement, delivery and service for the new JEA headquarters for the fourth phase in the amount of \$282,093.38, for a new not-to-exceed amount of \$3,762,128.09, subject to the availability of lawfully appropriated funds.

MOTION: Gabor Acs made a motion to approve Award Item 5 as amended in the committee packet. The motion was seconded by Joe Orfano and approved unanimously by the Awards Committee (5-0).

Informational Item:

No informational items were presented to the Awards Committee.

Ratifications:

No ratifications were presented to the Awards Committee

Public Comments:

No additional public comment speaking period was taken.

Adjournment:

Chair Datz adjourned the meeting at 10:28 a.m.

NOTE: These minutes provide a brief summary only of the Awards Committee meeting. For additional detail regarding the content of these minutes or discussions during the meeting, please review the meeting recording. The recording of this meeting as well as other relevant documents can be found at the link below:
https://www.jea.com/About/Procurement/Awards_Meeting_Agendas_and_Minutes/



Formal Bid and Award System

Award #2 August 25, 2022

Type of Award Request: REQUEST FOR PROPOSAL (RFP)

Requestor Name: Roh, Mir

Requestor Phone: (904) 665-5887

Project Title: One (1) – 230 kV Delta / 27 kV 50 MVA Transformer,
Nocatee

Project Location: JEA

Project Number: 8007832

Funds: Capital

Award Estimate: \$ 1,161,535.00

Scope of Work:

JEA is soliciting Bids for the equipment design, fabrication, and delivery of one (1) one 230kV - 26 kV transformer for the Nocatee T2 - Substation (the "Work" or "Services").

The scope of services the company will provide includes, however, is not limited to:

- Equipment Design
- Equipment Engineering
- Materials procurement
- Fabrication
- Drawings
- Delivery - Offload & Set on the pad

JEA IFB/RFP/State/City/GSA#: 1410795646

Purchasing Agent: Lovgren, Rodney D.

Is this a Ratification?: NO

RECOMMENDED AWARDEE(S):

Name	Contact Name	Address	Phone	Amount
PROLEC-GE WAUKESHA, INC.	Marianna Escobedo	Mariana.escobedo@prolec.energy.com	262-446- 8499	\$1,178,233.00

Amount for entire term of Contract/PO: \$1,178,233.00

Award Amount for remainder of this FY: \$0

Length of Contract/PO Term: Project Completion

Begin Date (mm/dd/yyyy): 09/01/2022

End Date (mm/dd/yyyy): Project Completion (Estimate 5/15/2025)

JSEB Requirement: N/A - Specialty Services

BIDDER:

Name	Unit Price	Evaluated Price
PROLEC-GE WAUKESHA, INC.	\$1,178,233.00	\$1,407,883.00
PTI TRANSFORMERS LP	\$1,609,400.00	\$1,736,000.00
DELTA STAR	\$2,288,520.00	\$2,670,020.00

Background/Recommendations:

Advertised on 07/05/2022. At response opening on 08/09/2022, JEA received three (3) Proposals. The evaluation is based 100% on the evaluated price (which takes into account load losses and lead time). Prolec-GE Waukesha, Inc. was deemed the lowest priced responsible and responsive Proposer. A copy of the Bid Form and Bid Workbook is attached as backup.

The Bidders submit their unit price (actual equipment price) and are evaluated on an evaluated price, which takes into account load losses and lead time to determine the Awardee. The load losses are determined by the equipment designer and input into a cost of ownership calculation, the lead time calculation was based on supplier lead time and a price/month calculation to arrive at the evaluated price.

The Award amount is 1.4% above the Budget Estimate. It is also noted this transformer has price adjustment through the release to manufacture. JEA understands this not the best-case scenario for procurements, however, market indices are used and 50% of the price is subject to price adjustment. For reference, the 2021 PPI for Large Specialty transformers was up approximately 30% in 2021 and price is deemed reasonable.

1410795646 - Request approval to award a contract to Prolec-GE Waukesha, Inc. for the supply of 1, 50 MVA transformer for the Nocatee Substation in the amount of \$1,178,233.00, subject to the availability of lawfully approved funds.

Manager: Hamilton, Darrell D. - Mgr Transmission and Substation Projects
Director: Acs, Gabor – Sr. Dir. Engineering & Projects
VP: Erixton, Ricky D. - VP Electric Systems

APPROVALS:

Stephen Datz 8/25/2022

Chairman, Awards Committee **Date**

Stephanus M Healy 8/25/2022

Budget Representative **Date**

1410795646 Nocatee 230-26 kV T2 Addition (BIDDER SHALL FILL IN YELLOW CELLS)

GE - Prolec Waukesha Inc

#	Transformer	Transformer Description	Unit Price (Base Price)	Guaranteed No-Load Losses		Guaranteed Load Losses		Guaranteed Auxiliary Losses		Evaluated Unit Price (Total Evaluated Bid Price)
				kW	Amount	kW	Amount	kW	Amount	
1	Nocatee T2 Addition	230 - 26 KV three phase transformer	\$ 1,178,233.00	22	\$5,000	115.5	\$1,000	8.3	\$500	\$1,407,883

MATERIALS AND SERVICE OPTIONS PRICING (BIDDER SHALL FILL IN YELLOW CELLS)

#	Material / Service Option	Description of Work	Unit Price	Qty	Payment Terms		Cashflow	
1	Field Service Technician	3 days of service during time period Monday - Friday, including travel and per diem.	\$ 7,325.00	1 Lot	5%	AOA	FY22	
2	Additional Optional Training	5 days of training, including travel, per diem	\$ 10,255.00	1 Lot	10%	Design Approval	FY23	\$58,911.65
3	In and Out Costs	Move in and out of Storage	\$ -	1 Lot	60%	RTM	FY24	\$117,823.30
4	Storage Costs	If Delivery delayed > 30 days from Ready to Ship. Delivery delays < 30 days shall be absorbed by the Company	\$ -	Per Month	20%	Delivery	FY25	\$1,001,498.05
5	Critical Spare Parts	One (1) HV bushing	\$ 3,600.00	each	5%	Acceptance		\$1,178,233.00
6	Critical Spare Parts	One (1) LV bushing	\$ 1,900.00	each	Lead Time	960		
7	Critical Spare Parts	One (1) fan	\$ 711.00	per assembly	Delivery	4/11/2025		
							30%	\$353,469.90

waukesha[®]

JEA

Prolec GE Waukesha Quotation 70011981

08/09/2022

REV. DESCRIPTION
0 Initial Release

CREATED BY
Mariana Escobedo

DATE
08/09/2022



Prolec-GE Waukesha, Inc. Quotation

08/09/2022

JEA
21 WEST CHURCH STREET
JACKSONVILLE, FL 32201

Inquiry	Nocatee T2 Addition
Quote Number	70011981
Specification Document(s)	TECH SPEC 50 MVA



TEAM CONTACT INFORMATION

Channel Partner	Application Engineer	Product Sales Specialist	Proposal & Order Coordinator
Richard DeLizza Electric Sales Associates TEL 954-385-8885 FAX 954-385-3266 richardd@electricsalesinc.com	Mariana Escobedo Prolec-GE Waukesha, Inc. TEL 262-446-8449 FAX 262-521-0198 mariana.escobedo@prolec.energy	Matthew Webb GE Grid Solutions TEL 919-330-7705 FAX matthew.webb@ge.com	Meredith Adams Prolec-GE Waukesha, Inc. TEL 919-580-3255 FAX 262-521-0198 meredith.adams@prolec.energy



QUOTE SUMMARY

Item Number	10
Price Per Unit	\$1,178,233.00
Quantity	1
Warranty	Prolec GE Waukesha's 5 Year Power Transformer Warranty
Rating Information	30/40/50 MVA, ONAN/ONAF/ONAF 3 Phase, 60 Hz., 65 Degree C rise 230 kV DELTA To 27 kV GRDY with UZD Reduced Capacity LTC
Ship To Destination	Jacksonville, FL
Ship To Location	Address or To Be Determined

If the Ship To Location is not known as of the bid issue date, then the quoted freight and rigging costs may be subject to adjustment based upon final delivery location.

Shipment Lead Time

30-32 months after Waukesha Order Acknowledgment issue date, subject to plant loading at the time of receipt of order.

Please consult the Channel Partner, Application Engineer or Product Sales Specialist identified in the CONTACT INFORMATION shown in this quotation if an alternate lead time is preferred.

Please advise Application Engineer or Product Sales Specialist identified in the CONTACT INFORMATION shown in this quotation if a specific ship date is required and a "PO Need By Date" will be provided.

ADDERS

- One (1) HV bushing \$3,600.00 each
- One (1) LV bushing \$1,900.00 each
- One (1) HV arrester \$1,700.00 each
- One (1) LV arrester \$ 457.00 each
- Gaskets \$ 958.00 per set
- Fan Assembly \$ 711.00 per assembly
- SFRA Testing (shipping configuration/fully assembled on pad) \$2,000.00 per test
- Field Assembly, Vacuum Fill and Test \$43,450.00 per unit

Customer requested Adders shall be added to the Transformer Price and they shall be payable in accordance with agreed upon Payment Terms unless otherwise stated by Waukesha in writing.

PRICE & PAYMENT TERMS POLICY

Price Adjustment Policy

At the time of final invoicing, Waukesha will provide an updated selling price based on the change in material costs for copper, core steel, plate steel, mineral oil, paper insulation and labor since the time of quotation. The final selling price will be (adjusted upwards or downwards) using the indices identified below and the latest available at time of shipment.

The following material indices are the base indices for this quotation:

Material	Name	Value	Unit	Index Date	% of Transformer Sales Price
Copper	HG-Comex	\$339.61	\$/cwt	Jul - 22	10.0%
Core Steel	Waukesha Internal Pricing Index	\$122.00	--	Jul - 22	8.0%
Plate Steel	AMM Cut-to-length Plate Carbon Grade FOB mill US\$/CWT	\$89.60	gross ton	Jul - 22	6.0%
Oil	Brent Crude Futures, Continuous Contract #1 (B1) (Front Month)	\$105.12	42-gal barrel	Jul - 22	2.0%
Insulation	PIX U.S. NBSK Index	\$1762.65	ton	Jul - 22	2.0%
Labor	U.S. BLS NAICS Code 335 - Mfg Labor Cost Index	\$24.37	--	Jul - 22	22.0%

Note: The Quoted Item Price(s) does not include sales, use, excise or any other taxes. Any taxes imposed shall be the responsibility of customer and will be invoiced accordingly, unless Prolec GE Waukesha is presented with a valid exemption certificate.

Confidential and Proprietary

This document contains proprietary information of Prolec-GE Waukesha, Inc. and may not be disclosed, copied, modified or used without the written permission of Prolec-GE Waukesha, Inc.

© 2022 Prolec-GE Waukesha, Inc. All Rights Reserved.

PAYMENT TERMS & MILESTONES

Payment milestones, subject to credit approval, are as follows:

- 5% to be invoiced at Order Acknowledgement
- 10% to be invoiced at Design Approval (not to exceed 2 weeks after release of drawing design)
- 60% to be invoiced at time of Release to Manufacturing
- 20% to be invoiced Delivery to pad/site
- 5% to be invoiced at Final Acceptance by JEA (not to exceed 30 days after delivery)

LATE PAYMENT POLICY

If payment is more than 10 days past the due date of the applicable invoice, Prolec GE Waukesha may:

1. Charge interest of 1-½% per month of the unpaid balance, and/or;
2. Withhold shipment of the affected Transformer until Customer is current on all payment obligations as set forth under the applicable Purchase Order.

For the avoidance of doubt, any delay in shipment due to Customer's late payment shall be credited to Prolec GE Waukesha in regards to the calculation of any liquidated damages. Any additional costs incurred due to postponed shipment under this section shall be the responsibility of Customer.



DRAWINGS

Approval drawings will be provided 30 weeks before ship date. Please contact the Application Engineer if an earlier date is required. Quoted Shipment Lead Time includes 1 weeks for customer to review and return approval drawings.

For orders requiring drawing approval, a release to immediately proceed with production must be returned to Waukesha within 1 weeks after drawing submittal to maintain scheduled date(s).



MINERAL OIL

Mineral Oil is included in the quoted transformer price. If mineral oil is shipped separately, pricing includes shipment/delivery of the oil within sixty (60) days of shipment of the transformer. After that date, any additional costs will be charged to the customer.



SHIPMENT

The above quoted transformer(s) will be **shipped dry by truck to your specified pad.**

Quoted freight and rigging prices are based on the delivery location and site conditions known as of the bid issue date and based on the free access required for Waukesha to unload the equipment without obstruction. Prices are subject to adjustment to the extent that there are changes to the delivery location, the delivery location's transportation route, or the site conditions ("Conditions") that would complicate the movement of the transformer(s).

Such Conditions that would complicate the movement of the transformer(s), include, but are not limited to: lack of existing roads; impassable conditions; extreme grade or any other condition that would prevent Waukesha from delivering to the specified site with a single crane lift; if clearance is not available due to highway construction; changes in state regulations; changes in bridge limitations; needed repairs to, but not limited to, roadway, delivery site access, or railways (customer or non-customer owned); obstructions such as existing fencing, or removal or reinstallation of any overhead or adjacent structures; insufficiently compacted soil (necessitating matting); oil containment pits or dikes around pad; debris or other condition beyond Waukesha's control or unknown at the time of bid.

Any additional costs associated with such Conditions will be charged to the customer.



WARRANTY VALIDATION / FIELD SERVICE

Services for **Warranty Validation / Field Supervision** ("Field Services") as identified in this quotation are included in the quoted transformer price. Other Field Services may be identified as an ADDER. Field Services standard work scope is included as an attachment. Quoted Field Service prices are based on free access to the site required to perform the field services and on the anticipated schedule with a single trip to the site. Quoted Field Service prices do not include any site specific or customer required access and/or safety training, any special and/or site-specific safety, PPE or environmental requirements, use of union labor or any local Sales or Use tax. Any additional direct costs associated with deviations from the proposed field service schedule will be charged to the Customer on a time and material basis.

Any Field Service offered in this quote, either as part of the quoted price or which can be elected as an adder, shall be subject to the terms of purchase of the transformer. In no event shall Waukesha have any obligation to identify, correct, abate, clean up, control, or remove from customer's premises any toxic or hazardous material.



TERMS & CONDITIONS

Prolec-GE Waukesha, Inc. offers this Quotation #70011981 (the "Quote") subject to the commercial terms of *JEA Contract #168953, between JEA and SPX Transformer Solutions, Inc., effective October 18th, 2017*, which shall apply to any order placed against this Quote, as modified by the following provisions of this Quote:

1. Price Per Unit;
2. Price & Payment Terms Policy; and
3. All technical content.

Any order placed against this Quote shall also be subject to the execution of the mutually agreed upon version of Amendment 3 to JEA Contract #168953, between JEA and SPX Transformer Solutions, Inc., effective October 18th, 2017.

After execution of a Purchase Order, should the United States of America or any state or local government authority impose any new tariff, legislation, regulation, or other remedy related to commodities or inputs affecting the work, the parties agree to equitably adjust the pricing under such Purchase Order as necessary to account for the financial effects or other direct or indirect effects of any such remedy that cannot be reasonably avoided by either party. Any adjustment subject to this clause will be reflected on the final invoice.

Prolec-GE Waukesha, Inc. reserves the right to correct clerical and administrative errors in this quotation, and other related documents.



WARRANTY

The above transformer is quoted with the **Waukesha Five Year Power Transformer Warranty** in lieu of all others specified, expressed or implied. To qualify for the Five Year Warranty, a Waukesha Service representative **must be** present at the time the transformer is dressed out, and both the primary and secondary must be protected from surges with arresters mounted on the transformer tank.

In addition to the above, full compliance to the Waukesha Instruction Manual is required to validate the warranty. A complete Instruction Manual is provided in the control box of every Waukesha Power Transformer.

CUSTOMER ACKNOWLEDGES THAT THIS WARRANTY MAY BE DEEMED VOID BY PROLEC-GE WAUKESHA, INC. UNTIL PAYMENT IS RECEIVED IN FULL FOR ALL UNDISPUTED INVOICES RELATED TO THE TRANSFORMER, STORAGE OF THE TRANSFORMER, AND ANY RELATED SERVICES.



TECHNICAL NOTES & COMMENTS

1. This proposal is based on the information provided in the Request for Quote documentation (RFQ) and, if applicable, any addendum to the RFQ received prior to proposal submittal. Customer requested changes after proposal submittal or at the time of order placement will be subject to commercial and technical review and acceptance by Waukesha. Acceptable impacts to scope, schedule, or cost may require a Waukesha Change Order Request Proposal. Implementation of the mutually agreed upon changes will commence after written acceptance by the Customer.
2. For units shipping Twenty-Four (24) months after approval drawing submittal, Waukesha may require design changes to ensure compliance with current industry, customer, or manufacturer standards, as well as available components. If applicable, these design changes, and potential cost impacts, will be reviewed with the customer by the project manager at time of manufacturing.
3. **Spec 6.0.** Short Circuit Design: A reference list of transformers short circuit tested successfully is attached, confirming that the proposed design(s) meet(s) the ANSI/IEEE short circuit requirements.
 - 3.1.1. The Short circuit force and stress calculations are performed using Rabin's method which has high accuracy for the Bfields inside the windings. The magnetic field is calculated for 100 axial and radial subdivisions of each winding. The short circuit currents are obtained for the most severe fault condition. The magnetic field and force densities, $J \times B$, are calculated along a fine grid-work of points throughout each winding. These are integrated (summed) appropriately to get net forces, which are required for calculating the stress. For axial forces especially, an offset is placed in one of the windings. Output includes: maximum hoop/buckling stresses in each winding, maximum radial and axial bending stresses, maximum compressive stresses on the key spacers, maximum tie-plate stress, and minimum pressure ring thickness needed to withstand the end thrust for offset windings. A flag is raised when material or buckling limits are exceeded. Stress limits are based on the proof stress of the material including an adequate margin.
 - 3.1.2. This analysis provides complete short circuit withstand requirements and design data for each specific design – a methodology preferred in the industry today.
4. **Spec 9.0.** Design review is NOT included.
5. **Spec 13.8.** The SEL 2414 is being provided with the device manufacturer's factory default settings. No programming will be supplied by Waukesha. If programing is required, please consult the Application Engineer for the adder.
6. **Spec 21.** Waukesha uses inhibited mineral oil (ANSI/ASTM D-3487) from Waukesha approved sources [see attached oil specification].
7. **Spec 22.** The quoted price includes the Waukesha standard paint finish system. The paint finish meets and exceeds C57.12.28 and C57.12.29 standards. Radiators will be hot-dipped galvanized steel construction and not painted. See the Transformer Paint Systems attachment for additional clarification.
8. Transformer has been recosted as duplicate of WT-05270. No heat run is included in the base price.



TECHNICAL EXCEPTIONS

1. **Spec 33.** The Prolec-GE Waukesha, Inc. Five Year Power Transformer Warranty, as attached to this quotation, shall apply in lieu of all other warranties, express or implied.



LOSS GUARANTEE

In accordance with latest revision of IEEE Standard C57.12.00, Section 5.9, No-load (core) loss guarantee on the enclosed performance specification(s) is based on the standard reference temperature of 20°C. Load (winding) loss guarantee is at the standard reference temperature of 85°C on 65°C rise rated transformers (or 75°C on 55/65°C rise rated transformers).

Waukesha tests no-load and load losses with less than 1.0% measurement error. These measurement errors are determined by a calibration system that is traceable to the National Institute of Standards and Technology (formerly the National Bureau of Standards) using methods described in NIST's Technical Note 1204.



Quotation # 70011981
08/09/2022



AWARD OF CONTRACT

In the event that the transformer contract is awarded to Prolec-GE Waukesha, Inc., please provide the following text on the purchase order to help expedite order processing: **Unit(s) will be Designed, Manufactured, Tested, Shipped, Sold and Invoiced in accordance with Prolec-GE Waukesha, Inc. Quotation 70011981, dated 08/09/2022.**



VALIDITY

This bid will remain in effect for 30 days unless changed in the interim by written notice from Waukesha. Extensions to the 30-day validity may be considered, as required, to facilitate the order process.

Sincerely,
Prolec-GE Waukesha, Inc.

Mariana Escobedo
Application Engineer



Quotation # 70011981
08/09/2022

ENCLOSURES

Performance Specification(s)

Cancellation/Delay Policy

Waukesha Five Year Power Transformer Warranty

Waukesha Warranty Validation

Assembly Vacuum Filling & Testing: Units Shipped Without Oil

Waukesha Service Solutions

Transformer Oil Specification

Transformer Paint Systems

Transformer Tank Design & Construction

Short Circuit Test Results

Waukesha UZD

Load Tap Changer Filtration Systems

Proposal Form / Data Sheets

Confidential and Proprietary

This document contains proprietary information of Prolec-GE Waukesha, Inc. and may not be disclosed, copied, modified or used without the written permission of Prolec-GE Waukesha, Inc.

© 2022 Prolec-GE Waukesha, Inc. All Rights Reserved.

FOR: 294 JEA

70011981

Item No: 000010

Project Name: 30/40/50MVA, 230-26.4kV, LTC

TRANSFORMER RATINGS										
Phase	3	Cooling Class	HV Volts		XV Volts		YV Volts		ZV (TV) Volts	
Frequency	60	Class	230,000	--	27,000	--	--	--	--	--
Temp Rise °C	65		Delta	--	GrdY	--	--	--	--	--
Insulating Oil	Oil	ONAN	30.00	--	30.00	--	--	--	--	--
		ONAF	40.00	--	40.00	--	--	--	--	--
		ONAF	50.00	--	50.00	--	--	--	--	--

ADDITIONAL TAP VOLTAGES				
Terminal	Style	Taps or KV		Capacity
HV	DETC	+ 2 / - 2	@ 2.500 %	FULL REDUCED
XV	UZD	+ 16 / - 16	@ 0.625 %	

PERCENT IMPEDANCE VOLTS		
%	Windings	At MVA
9.00	H-X	30.0
--	H-Y	--
--	X-Y	--

AUXILIARY LOSSES AND SOUND LEVEL			
MVA	Class	Cooling	Sound Level dB
30.00	ONAN	--	76
40.00	ONAF	2,600	78
50.00	ONAF	5,300	79

The above values for cooling loss do not include ancillary equipment (heaters, control devices, etc.) losses of 3,000 watts

INSULATION LEVELS (KV)			
Terminal	Winding	Bushing	
HV Line	825	--	900
HV Neutral	--	--	--
XV Line	200	--	200
XV Neutral	110	--	200
YV Line	--	--	--
YV Neutral	--	--	--
ZV (TV) Line	--	--	--
ZV (TV) Neutral	--	--	--

PERFORMANCE BASED ON A LOADING OF				
HV Winding	230,000	Volts @	30.00	MVA
XV Winding	27,000	Volts @	30.00	MVA
YV Winding	--	Volts @	--	MVA
ZV (TV) Winding	--	Volts @	--	MVA

EFFICIENCIES				
Base MVA (ONAN) = 100%				
Load	100%	75%	50%	25%
Percent	99.54	99.61	99.66	99.61

REGULATION	
Power Factor	Percent Regulation
1.0	0.79
0.9	4.57
0.8	5.93

PERFORMANCE DATA No Load Temp: 20 °C/ Load Loss Temp: 85 °C				
Exciting Current (Percent) and Loss (Watts)				
Excitation	Exciting Current(%)	No Load Loss	Load Loss	Total Loss
100%	.500	22,000	115,500	137,500

MECHANICAL DATA - Not for Construction				Dimensions are in inches & weights are in pounds (approx.values)	
Outline Drawing Number:			Shipping: Dry by Truck		
	Base	Assembled	Shipping	Weight (lbs)	
Height (A)	--	277	156	Core and Coils	73,107
Width (B)	188	393	238	Tank and Fittings	54,609
Depth (C)	89	207	129	Liquid (9,695 gallons)	72,302
Height Over Cover (D)	--	150	150	Total Weight	204,251
				Shipping Weight, Heaviest Piece	114,446



Building Community®

Procurement Bid Office
Customer Center 1st Floor, Room 002
21 W. Church Street
Jacksonville, Florida 32202

July 13, 2022

Addendum Number: **One (1)**

Title: **One Transformer Nocatee 230-26 kV T2 Addition**

JEA Solicitation Number: **1410795646**

Response Due Date: **See Zycus Platform for Close Date and time**

Time of Opening: **2:00 PM**

This addendum is for the purpose of making the following additions, deletions and changes.

SUPPLIER INQUIRY: The LV voltage in the spec showing 27 kV, and the inquiry is making reference to 26 kV.

JEA RESPONSE: The one shown on the technical specification (27kV) is correct

SUPPLIER INQUIRY: What is the delivery address?

JEA RESPONSE: 14981 Philips Highway, Jacksonville, FL 32256.

Acknowledge receipt of this addendum on the Response Form

1410795646 - APPENDIX B PROPOSAL FORM

RFP One Transformer Nocatee 230-26 kV T2 Addition

COMPANY INFORMATION:

COMPANY NAME: Prolec-GE Waukesha, Inc.
 BUSINESS ADDRESS: 400 South Prairie Avenue
 CITY, STATE, ZIP CODE: Waukesha, Wisconsin 53186
 TELEPHONE: (262) 446-8449
 FAX: _____
 EMAIL OF CONTACT: Mariana.escobedo@prolec.energy

Total Evaluated Bid Price

Description	Total Bid Price
Total Evaluated Price from the Bid Workbook	\$ 1,407,883.00

Upload 1 electronic signed copy of this Proposal your Proposal Submission

Company's Certification

By submitting this Proposal, the Proposer certifies that it has read and reviewed all of the documents pertaining to this RFP and agrees to abide by the terms and conditions set forth therein, that the person signing below is an authorized representative of the company, that the company is legally authorized to do business in the State of Florida, and that the company maintains in active status an appropriate license for the work. The company certifies that its recent, current, and projected workload will not interfere with the company's ability to Work in a professional, diligent and timely manner.

The Proposer certifies, under penalty of perjury, that it holds all licenses, permits, certifications, insurances, bonds, and other credentials required by law, contract or practice to perform the Work. The Proposer also certifies that, upon the prospect of any change in the status of applicable licenses, permits, certifications, insurances, bonds or other credentials, the Company shall immediately notify JEA of status change.

We have received addenda 1 through _____

mariana escobedo
 Signature of Authorize Officer of Company or Agent

Mariana Escobedo/ Application Engineer
 Printed Name & Title

08/09/2022
 Date

(262) 446-8449
 Phone Number



Cancellation / Delay Policy

Up to 35 MVA Base Rating

1. Cancellation of an order will be accepted after the purchaser has given written notice. If the cancellation occurs during the period from the date of order entry to twelve (12) weeks after order acknowledgement, the cancellation charges will be the actual work hours expended on the job performed at a rate of \$250 per hour or a minimum of five percent (5%) of the purchase price, whichever is greater.
2. If the cancellation occurs after approval drawings have been issued by Waukesha, the termination charge will be thirty percent (30%) of the purchase price.
3. Notwithstanding items 1 and 2 above, if the order is cancelled twenty-six (26) weeks or less prior to shipment, the cancellation charge shall be one hundred percent (100%) of the purchase price.
4. If the order is suspended or shipment is delayed twenty-six (26) weeks or less prior to the scheduled ship date, the equipment will be completed and invoiced. Storage at Waukesha's site shall be subject to availability and any related costs shall be at the customer's expense.
5. If a request to delay shipment changes the scheduled ship date, a mutually agreed upon adjustment to the base price may be necessary.



Five Year Power Transformer Warranty

Prolec-GE Waukesha, Inc. (Waukesha), warrants to the original purchaser that the complete transformer, together with all parts included in the original purchase (the "Transformer"), has been designed in accordance with the specifications of the original purchaser and that the Transformer will be free from defects in material and workmanship under normal use and service for a period of five (5) years from the date of arrival of the Transformer at its destination from the factory. Waukesha's liability under this warranty does not extend to defects caused by vandalism, improper installation, improper maintenance, alterations by purchaser, purchaser-furnished materials, or improper operation. For this warranty to be valid, Waukesha requires that all transformer windings shall be protected from surges with arresters mounted on the transformer tank or an insulation coordination study may be required.

A customer service representative must be present during field assembly, vacuum filling (if required) and inspection of the installation prior to energization. In the event that the Transformer is relocated, a customer service representative must be present during field re-assembly, vacuum-filling (if required) and inspection of the re-installation prior to re-energization.

Purchaser forfeits the provisions of the Five Year Warranty if either of these service requirements is not followed.

If any part is found to contain defects in material and/or workmanship during the five year warranty period, Waukesha's liability and Purchaser's remedies under this warranty shall be limited solely to repair or replacement, at Waukesha's option, of the defective part. Decision on the method and extent of repairs rests solely with Waukesha. Purchaser shall give Waukesha prompt written notice of any claim hereunder. Waukesha shall be given a reasonable opportunity to investigate all claims, and no parts may be returned to Waukesha without authorization and instructions from the Customer Service Department.

During the first year, this warranty covers any freight within the 48 contiguous states by common carrier in full. This warranty also covers the cost of removal from the site and reinstallation after repair, subject to a limit of 10% of the original selling price. Costs of moving structures or associated equipment are excluded. During the last four (4) years, transportation, moving and reinstallation costs are excluded from this warranty.

Under no circumstances will Waukesha be responsible for damage in excess of the sale price to Purchaser for the goods and/or services for which damages are claimed.

THIS WARRANTY IS EXCLUSIVE AND IS IN LIEU OF ALL OTHER WARRANTIES, EXPRESS OR IMPLIED, INCLUDING, BUT NOT LIMITED TO, ANY IMPLIED WARRANTY OF MERCHANTABILITY OR FITNESS FOR A PARTICULAR PURPOSE. WAUKESHA SHALL NOT BE LIABLE FOR ANY INCIDENTAL OR CONSEQUENTIAL DAMAGES OR EXPENSES OF ANY KIND, INCLUDING LOSS OF PROFITS.

In the event a performance bond is provided as part of the contract to which this warranty applies, the Surety's liability shall be limited to one (1) year from the date of delivery of the Transformer. The remaining four (4) year warranty period is solely the obligation of Waukesha.

CUSTOMER ACKNOWLEDGES THAT THIS WARRANTY MAY BE DEEMED VOID BY WAUKESHA UNTIL PAYMENT IS RECEIVED IN FULL FOR ALL UNDISPUTED INVOICES RELATED TO THE TRANSFORMER, STORAGE OF THE TRANSFORMER, AND ANY RELATED SERVICES.

Goldsboro, NC 800.758.4384 | Waukesha, WI 800.835.2732 | www.waukeshatransformers.com

TC04-0122H



Prolec GE Waukesha Warranty Validation (<100MVA)

Waukesha® Service personnel are required to provide assistance to a customer during installation of the transformer and verify proper assembly to facilitate activation of the applicable warranty.

Minimum requirements for warranty validation are as follows:

- Waukesha® Service personnel will perform internal inspection of transformer and witness the installation and connection of bushings.
- Waukesha® Service personnel will complete service warranty validation checklist.
- Customer will provide vacuum filling records, where applicable.
- Customer will perform electrical acceptance tests and provide copies of test results to Waukesha; as specified in Waukesha's Pre-operational Testing Instruction Booklet 2012, the minimum acceptance tests include:
 - Core Insulation Resistance (Megger)
 - Winding Insulation Resistance
 - Transformer Turns Ratio
 - Insulation Power Factor of Bushings and Windings (Doble)
 - General Oil Chemistry Tests – Dielectric Strength, Power Factor and Moisture Content

Pricing is based upon a single mobilization to jobsite during standard work hours. When requested assistance lasts longer than 5 days, requires overtime assistance or multiple mobilizations to the site, the extra work will be billed in accordance with rates designated on the current Waukesha® Service Technician & Specialist Rate Schedule sheet.

Assembly, Vacuum Filling & Testing: Units Shipped Without Oil

applicable for transformers < 100 MVA base rating and < 345kV

If included in the quoted price or selected as an “adder” as outlined in the proposal, Waukesha® Service crews and equipment will perform transformer installation once the transformer has been placed on the pad. Assembly and testing work will include the following:

ASSEMBLY

- Install, connect and tape, as necessary, all bushings
- Hang and brace radiators and/or fans
- Mount oil preservation system, if required
- Mount lightning arresters, if required
- Mount control cabinet, if required
- Mount any miscellaneous items removed for shipment
- Check all internal clearances including DETC and LTC (if equipped) for proper alignment and timing
- Hang any conduit removed for shipment; pull and terminate associated wiring

OIL FILLING

- Elevate core/coil temperature, if necessary
- Conduct vacuum leak test
- Vacuum fill in accordance with Waukesha's Instruction Leaflet Document No. 2011
- Pull vacuum at a level of 1 Torr (1,000 micron, 1mm of Hg) or less and hold for a minimum of 8 hours
- Vacuum fill transformer oil while maintaining a vacuum level of 5 Torr or less
- Fill conservator tank or activate nitrogen system, as appropriate for transformer design

TESTING

As specified in Waukesha's Pre-operational Testing Instruction Booklet No. 2012, the minimum acceptance tests include the following:

- Bushing power factor and capacitance
- Core megger
- Transformer turns ratio
- Insulation power factor
- Insulation resistance
- Functional check of unit control cabinet
- Oil test after filling
 1. Moisture content
 2. Power factor
 3. Dielectric strength
 4. Flash and fire point (natural ester fluid filled units only)

See next page for Scope Clarifications.



SCOPE CLARIFICATIONS

For all transformer installations, the following apply:

- Purchaser shall be responsible for switching, lock out and grounding of any equipment necessary to establish safe work area.
- Purchaser shall provide suitable, free, clear, unlimited and compacted access route, roads and area around work location for access of service equipment.
- Purchaser shall connect all external protection, control and relay wiring, as required.
- Purchaser shall connect all external bushing terminations or bus work, as required.
- Purchaser shall assemble any deluge systems, as required.
- Waukesha® Service crews will compile all crating and waste material in designated area; however, purchaser shall be responsible for disposal of solid wastes.
- Purchaser shall provide one open top drum and one closed top drum for disposal of all waste, flush and scrap oil generated in execution of work.
- Purchaser shall provide communication and sanitation facilities.
- No provisions have been included for secondary oil containment as may be required for compliance to local site SPCC programs.
- No provisions have been included for Union Labor requirements.
- Any site specific or customer required access and/or safety training is not included in pricing and would be billed at applicable field service rates.
- If a natural ester fluid is included in this quotation, acceptance test results of that fluid will differ from the typical values of transformers filled with mineral oil. Insulation power factor values are expected to increase and insulation resistance values are expected to decrease when compared to test values with mineral oil insulation system.
- If a natural ester fluid is included in this quotation, Purchaser shall be responsible for disposal of all totes/drums utilized for make-up and flush oil that is generated during course of project. Waukesha can arrange for disposal upon request at additional cost.

Should additional requirements, tests and/or processing procedures apply, please contact Waukesha® Service for pricing at 800.758.4384.

Goldsboro, NC 800.758.4384 | Waukesha, WI 800.835.2732 | www.waukeshatransformers.com

TC09-0122E

Transformer Service Solutions to 765kV

Available for ALL Manufacturers' Units

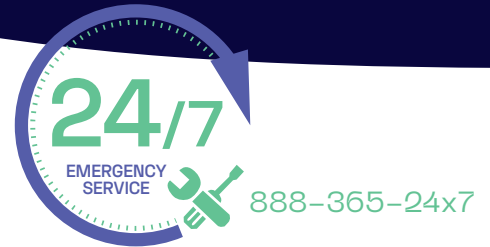

Waukesha's service team focuses on maintaining performance quality, reliability and life of transformers and load tap changers throughout your electric power system — whether manufactured by Prolec GE Waukesha or other suppliers. Our mission is simple: to keep your transformers up and running with responsive and cost-effective service and maintenance support 24/7/365.

TRANSFORMER INSTALLATION & LOGISTICS

- Heavy Hauling
- Rigging
- Assembly
- Oil Filling
- Acceptance Testing
- Relocation

TRANSFORMER TESTING SERVICES

- Insulation Resistance
- Power Factor
- Transformer Turns Ratio
- Winding Resistance
- CT Testing
- Leakage Reactance
- Winding Excitation & Alarm Checks
- Gauge Calibration
- Sweep Frequency Response Analysis
- Dissolved Gas Analysis & General Chemistry
- Materials Analysis

TRANSFORMER MAINTENANCE

- Inspections
- Component Addition & Replacement
- Regasketing
- Leak Repairs
- Life Extension
- Oil Preservation System Upgrades
- Control Upgrades
- Retrofits
- Removal, Sourcing and Installation of Conservator Aircells, Regardless of OEM

TRANSFORMER OIL PROCESSING

- Field Dry Out
- Vacuum Filling
- Hot Oil Processing
- Cryogenic Drying (Cold Traps)
- Fullers Earth Reclamation
- Natural Ester Retrofills

SPARE PARTS

- Bushings/Arresters
- Cooling Equipment
- Gauges/Controls
- Gaskets
- Transformer Health Products®
- LTC Parts

TRAINING SERVICES

- LTC Training
- Maintenance Training
- Testing Training
- Print Reading
- Oil Processing Training

LTC MAINTENANCE

- All Manufacturers
- Inspections
- Overhauls
- Upgrade Kits
- Filtration Installation
- Core Replacement
- Vacuum Retrofits

TECHNICAL SERVICES

- Condition Assessment Studies
- Life Assessment Studies
- Thermal Uprate Studies
- Component Retrofits
- Failure Analysis
- Feasibility Studies
- Technical Supervision



LOCATION

Prolec-GE Waukesha, Inc.
2701 US Hwy 117 South
Goldsboro, NC 27530
800-758-4384

waukeshaservice.com



Transformer Oil Specification

(as received from refiner)

Waukesha's standard is **inhibited mineral oil with 0.3% max DBPC (oxidation inhibitor)**. Oil meeting other specific customer requirements may be available upon request.

Oil is purchased only from approved domestic sources, and for each approved source, oil has been tested and proven to meet the following specification values:

KEY PROPERTIES	ASTM TEST METHOD	IEEE / ASTM D-3487 LIMITS
Physical Properties		
Color	D1500	0.5 max
Flash point, °C	D92	145 min
Interfacial tension @ 25°C (dynes/centimeter)	D971	40 min
Pour point, °C	D97	-40 max
Specific gravity @ 15°C/15°C	D1298	0.91 max
Viscosity, SSU/cSt @	D88 / D445	
100°C		36 / 3.0 max
40°C		60 / 11 max
0°C		350 / 76.0 max
Polychlorinated Biphenyls (PCBs) ppm	D-4059	Not Detectable
Visual appearance	D1524	Clear and Bright
Chemical Properties		
Aniline point, °C	D611	63 min
Approved antioxidant content, wt %	D2668, D1473	0.30 max
Corrosive sulfur ¹ Test to be run for 48 hours @ 150°C	D1275	Non-Corrosive
Moisture, ppm	D1533	35 max*
Neutralization number, mg KOH/g of oil	D974	0.03 max
Oxidation stability Method A (acid / sludge test)	D2440	
72 hours sludge, wt %		0.10 max
Neutralization value, mg KOH/g		0.30 max
164 hours sludge, wt %		0.20 max
Neutralization value, mg KOH/g		0.40 max

*35 ppm max as received from refiner; Waukesha dehumidifies to lower value for installation in transformer.

Continued on next page...

KEY PROPERTIES	ASTM TEST METHOD	IEEE / ASTM D-3487 LIMITS
Electrical Properties		
Dielectric breakdown voltage at 60 hertz Disc electrodes, kV VDE electrodes, kV @ 0.040-in. gap or @ 0.080-in. gap	D877 D1816* D1816*	30 min 28 min 56 min
Dielectric breakdown voltage 25°C impulse conditions, kV Needle (negative)-to-sphere (grounded) @ 1-in gap	D3300	145 min
Power factor at 60 hertz, % at: 25°C 100°C	D924 D924	0.05 max 0.30 max
Gassing Tendency @ 80°C (µL/min)	D-2300 B	+ 30 max

*D1816 only applies to new oil that has been filtered, dehumidified and degasified.

Oil shall be PCB-free to existing current law. Properties as listed are only attainable on new oil as received from the refinery. It is expected that oil contained in equipment as received from the manufacturer when properly sampled from such equipment usually exhibits characteristics slightly different from those obtained from new oil, which has not been in contact with apparatus constructional materials. In such cases, the oil, as drawn from the transformer, should be evaluated per IEEE C57.106 latest revision for acceptance and maintenance of insulating oil in equipment.

IN-PLANT QUALITY CONTROL

In addition to extensive testing by an independent testing laboratory to determine approved sources of supply, Waukesha performs acceptance tests on each shipment of oil received.

Waukesha receives oil at its plants in dedicated tank cars and trucks. Upon arrival, acceptance testing is performed before the oil is unloaded into a Waukesha storage tank. Prior to filling a transformer, oil is degasified and dehumidified, passed through Fullers Earth and re-filtered at various points in the process.

Transformer Paint Systems

Waukesha provides as standard a coating system that exceeds the requirements of IEEE C57.12.29, “Enclosure Integrity—Above-Ground Pad-Mounted Enclosures” specification (the specification for pad-mounted equipment). The coating system consists of an epoxy primer with a polyurethane topcoat. This process has been both lab tested and field evaluated.

Coating system processes used for the transformer are as follows:

SUBSTRATE

Hot rolled low alloy steel.

SURFACE PREPARATION

The performance of a coating system is highly dependent upon the condition of the surface to which the coating is applied. All sharp edges, scale, weld spatter and surface irregularities shall be removed by shot blasting, hand grinding, sanding or other appropriate manufacturing procedures.

Shot blasted per SSPC-SP6 (Commercial Blast Cleaning) then detergent washed with an iron phosphate conversion coating and a non-chrome seal.

-or-

Blast to SSPC-SP10 (near white) condition and apply paint within 24 hours.

COATING PROCEDURE

Interior of tank and tank cover are coated using a white, two-part, oil-resistant epoxy enamel. The exterior surfaces are first painted using a two-part epoxy primer then top coated using a two-part urethane enamel. All coating materials are applied using plural component equipment that automatically measures and mixes the paint systems to eliminate operator error. The coatings are then force cured to produce a uniform cured coating.

COATING RESULT

Interior coating compatible with transformer oil per ASTM 3455; 3 mil exterior coating capable of meeting IEEE C57.12.29.

The two-component coatings used for painted surfaces have a high crosslink density and an exceptional barrier property characteristic. Two-component systems develop full corrosion resistance at a 2 mil total film thickness (primer and topcoat); in fact, the mechanical properties of any organic coating will deteriorate as the thickness approaches 5 mils. For these reasons, the Waukesha paint system exhibits optimal performance at a nominal 3 mil thickness (range 3–5 mils).

NOTE: Radiators are purchased from an outside supplier and are hot dip galvanized or painted to meet the customer's specification.

See next page for paint system test results.



EXTERIOR PAINT SYSTEM PERFORMANCE

TEST	ASTM TEST METHOD	RESULTS
Adhesion	D-3359-B	No Removal
Salt Spray	B-117	1500 Hrs, 1/32" Loss of Adhesion
Humidity	D2247	1000 Hrs @ 40°C; No Blisters
Impact	D-2794	160 in/lbs., No Chipping
U-V Resistance	G-53	500 Hrs, Less than 15% Gloss Change
Taber Abrasion	D-4060	More than 3,000 Cycles @ 3 Mils
Oil Resistance	72 Hrs @ 100°C	No Effect
Thermal Aging	1,000 Hrs @ 120°C	No Effect
Pencil Hardness	D-3363	2-H After 2 Weeks
VOCs	D-2369	3.5 #/gal.

Transformer Tank Design and Construction

Tank integrity is essential for reliability and long transformer life. To help ensure a perfect fit to the application, Waukesha designs all transformer tanks to high internal standards while taking customer specifications into account.

All Waukesha® transformer tanks feature the following:

- Hot-rolled, low carbon steel plates plasma cut to critical tolerances then joined via submerged arc welding to ensure against cracked seams and irregularities
- Formed tank corners which eliminates high stress corner welds
- Jack pads and lifting hooks for lifting, jacking or pulling, meeting the criteria of C57.12.10
- Guides used to solidly "fit" and brace the completed core and coil assembly inside the tank to prevent shifting during shipment
- Slightly domed covers to help prevent water accumulation
- Raised flanges with machined gasket grooves in cover openings
- Conveniently located hand holes and/or manholes for easy access to the lower end of bushings, terminal boards and upper portion of core and coil assembly

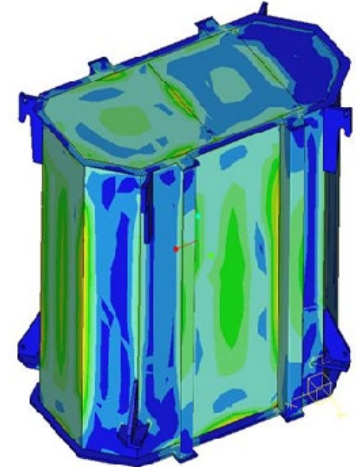

Finite Element Analysis

Additionally, Waukesha's standard coating system exceeds the requirements of ANSI/IEEE C57.12.28, the specification for pad-mounted equipment.

TANK DESIGN STYLES

Waukesha uses several tank design styles to optimize the use of tank steel, transformer oil and lead time. All are designed to withstand full vacuum and pressures 25% greater than achieved during normal operation. The tank design shown on the preliminary bid outline is an initial estimate and *subject to change based on the optimum design criteria*. The best tank design is chosen based on unit specifications, including overall dimensions, equipment location, cooling requirements and shipping profile.

Octagonal Tank Design

Octagonal end walls are used when possible to optimize total oil volume and installed transformer weight, resulting in lower overall footprint.



Rectangular Tank Design

Horizontal stiffener designs can be used where full length walls are necessary for mounting various accessories. This configuration can also be used for air expansion on N2 and sealed tank designs to reduce tank height for improved shipping clearances.



Vertical Stiffener Design

Vertical stiffeners are used on larger units when necessary to reduce shipping profile width by using multiple vertical stiffeners. This design is also used on some longer units to produce an optimum tank design with minimal tank wall deflection.



Short Circuit Testing

DESIGN

All Waukesha® transformers are designed with state-of-the-art tools and manufactured in our factories per strict quality assurance plans to ensure survival through even the worst-case faults. To start, worst-case fault currents are determined assuming infinite bus supply (zero system impedance) for single line to ground as well as three phase faults at the transformer terminals. Using this fault current, all designs are analyzed with detailed stress calculations for worst case combinations of tap positions (LTC and DETC) for all known failure modes. These stresses are then compared to known strengths for each of the failure modes and must have acceptable design margins as set by Waukesha.

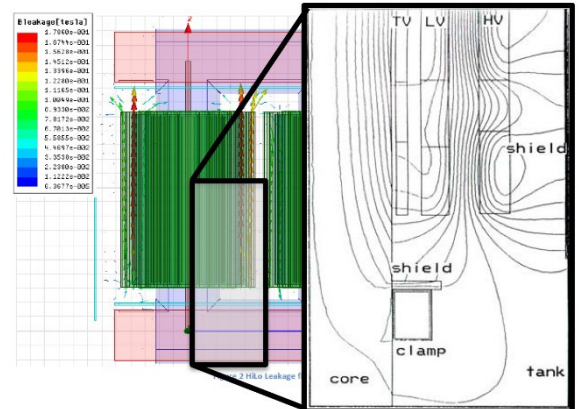

MANUFACTURING

All windings are manufactured with rectangular, electrolytic-grade copper conductor or epoxy-bonded, continuously transposed cable (CTC). Radial spacers are locked to strips fastened to the winding cylinders. These radial spacers and other support blocks in the pressure column are manufactured from high density, pre-compressed pressboard or laminated wood. Other specialized components—angle/cap rings, coil collars and static ring insulation—are manufactured from molded grade, soft pressboard as required.



Fully Distributed Regulating Voltage Winding

After the windings are completed, they are thoroughly dried using hot air. After removal from the dryout chamber, coils are hydraulically pressed successively using a predetermined force then pressed again using the clamping force they will experience when fully assembled. When required, radial spacers are adjusted to achieve the required design height, maintaining the design's "electrical center" of the windings for ampere-turn balance, stray flux and axial force mitigation.

The coils are clamped in place by first applying a precise, hydraulic force which compresses the windings to the design height as verified in the coil sizing operation (as described in the paragraph above). In this condition, the coils are fastened in place to maintain a compressive force as specified by Waukesha engineering. Verifying exact clamping pressure and winding height in this manner helps guarantee a finished product that conforms to what was designed in engineering.

The entire clamping technique and underlying scientific principles on which it is based are major contributors to the outstanding Waukesha service record.

See next page for a list of transformers tested for short-circuit at high power laboratories.

WAUKESHA SHORT CIRCUIT TEST LIST:

MVA RATING	HV RATING	LV RATING
0.833	67 kV Delta	12.47 kV Wye
5 / 6.25	24.4 kV Delta	4.16 kV Wye
5 / 6.25	26.4 kV Delta	4.16 kV Wye
5 / 6.25	59.58 kV Wye	10.66 kV Wye
5 / 6.25	67 kV Delta	12.47 kV Wye
7.5 / 9.375	69 kV Delta	12.47 kV Wye
7.5 / 9.375	138 x 69 kV Delta	26.4 X 13.2 kV Wye
12 / 16 / 20	66 kV Delta	14.4 kV Wye
15 / 20	67 kV Delta	12.47 kV Wye
15 / 20 / 25	69 kV Delta	12.47 kV Wye
1.0	12.47 kV Delta	4.8 kV Wye
3.75	23 kV Delta	4.8 kV Wye
5.0	34.4 kV Delta	12.47 kV Delta
5.0	69 kV Delta	12.47 kV Delta
7.5	23 kV Delta	12.47 kV Wye
7.5	115 kV Delta	13.2 kV Wye
10.0	43.8 kV Delta	24.9 X 12.47 kV Wye
5 / 6.2	34.5 kV Delta	12.47 kV Wye
15 / 20	67 kV Delta	12.5 kV Wye
15 / 20	67 kV Delta	12.5 kV Wye
15 / 20 / 25	120 kV Delta	13.2 kV Wye
15 / 20 / 25	120 kV Delta	13.2 kV Wye
18	39.5 kV Delta	4.8 kV Delta
30	230 kV Delta	55.2 kV Delta



Helical Winding with CTC

Continuous
Disk
Winding
with
Copper
Magnet
Wire



Waukesha® UZD®

The Service-Proven Load Tap Changer!

With more than 7,000 units installed, Waukesha's UZD load tap changers boast an excellent field performance record. Design improvements made in the 1990s reduced the already low failure rate to one of the lowest in our industry, reduced maintenance costs and increased maintenance intervals. When compared to the cost of downtime, out-of-service operation and costly repairs, the UZD LTC system is a cost-effective way to keep your transformer operating as smoothly as the day it was installed!

A load tap changer, regardless of manufacturer, is a complex engineered device with numerous moving parts requiring precise engineering, correct material selection and controlled manufacturing to operate reliably for a long period of time.

In many cases, the true reliability of a load tap changer becomes evident only when a transformer has been in service for several years and the load tap changer accumulates 100,000 plus mechanical operations.

Since the UZD's initial introduction in 1970, it has accumulated in excess of 110,000 YEARS of operational service and an estimated 550 MILLION switching operations. Ongoing continuous improvement programs, in coordination with our customers, resulted in several design enhancements that help increase overall operational life as well as virtually eliminate the need to perform maintenance inside the oil.

KEY ADVANTAGES OF THE WAUKESHA® UZD® LOAD TAP CHANGER

Re-Engineered Reversing Switch and Current Collector ("Bow-tie") System

Since the re-engineered reversing switch and current collector system were introduced in 1997, no known failures due to coking have occurred.

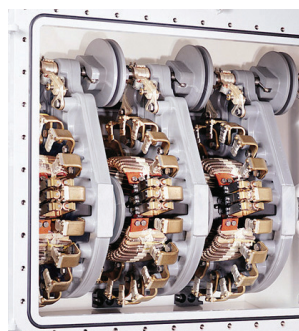

Silver-Plated Copper Contacts with Tungsten Copper Inserts
Stationary contacts for long life and low temperature rise.

Resistive Bridging

High-speed operation results in extremely low contact wear and manageable levels of arcing by-products. For optimal results, we recommend applying an oil filtration system.

LTC and Series Transformer System

For applications with greater than 600 ampere current ratings, a series transformer is recommended to allow for an optimal volts/turn design of the main transformer windings, even step regulation and smaller leads, while facilitating a reduction in current through the LTC contacts for less contact wear and longer life; a power-class series transformer design is recommended for high reliability.

Spring Drive Mechanism

Stored energy system delivers split-second operation for minimum arcing time. In addition, each tap change is uniform and unaffected by possible auxiliary voltage fluctuations.

OTHER NOTABLE FEATURES OF THE WAUKESHA® UZD® LTC

Single Set of Spare Contact Parts

Due to the design flexibility of the series transformer, we utilize a single model LTC across a wide range of transformer voltage and power ratings.

Easy to Maintain with Few Moving Parts

A single collector arm incorporates both the arcing contacts and tap selector contacts which reduces linkages, wear points and potential maintenance.

RECOMMENDED ACCESSORIES

Clean, dry oil increases dielectric strength, thereby reducing arcing time. The accessories below help keep carbon particles, metal particles and moisture out of tap changer oil:

OF2 Oil Filtration System

Designed to remove carbon and metallic particles produced during normal LTC operation. The system includes an adjustable timer for customized configuration and a 1/2 HP, fully enclosed, continuous run rated, auto-thermal resetting motor.



Another feature of the OF2 is a tilt-out, tool-free filter replacement system which allows the filter cartridge to be changed without disconnecting oil lines or reversing the pump—dirty oil stays in the filter while LTC compartment oil stays clean. Additionally, our OF2 ships standard with a unique, high-efficiency, depth-type filter that offers long element life and provides the capability to filter more efficiently than pleated-type models. The system is also adaptable to a variety of industry standard filters. Other features include low flow and high pressure alarms, anti-condensation cabinet heater and remote system shut down relay.

Single and Dual Column Breathers

An economical solution for LTCs, our single column breather efficiently dehydrates the air coming into your transformer then regenerates the desiccant while the transformer is not “inhaling,” keeping moisture out.

The dual column design provides a continuous stream of dry air to a transformer, regardless of the amount of moisture being absorbed. This feature allows customers to standardize on one breather to support every transformer on their system, maximizing spend and limiting the number of parts needed to manage inventory and/or new orders.



CONTACT LIFE

Predicted contact life of the selector switches' fixed and moving contacts is shown below. Since most transformers are not consistently operated at maximum nameplate rating, some tap changes will be made at lower currents. These lower currents allow for less contact erosion due to arcing, so contact life may be longer than what is illustrated on this curve.

PREDICTED CONTACT LIFE WITH BREAKING CURRENTS

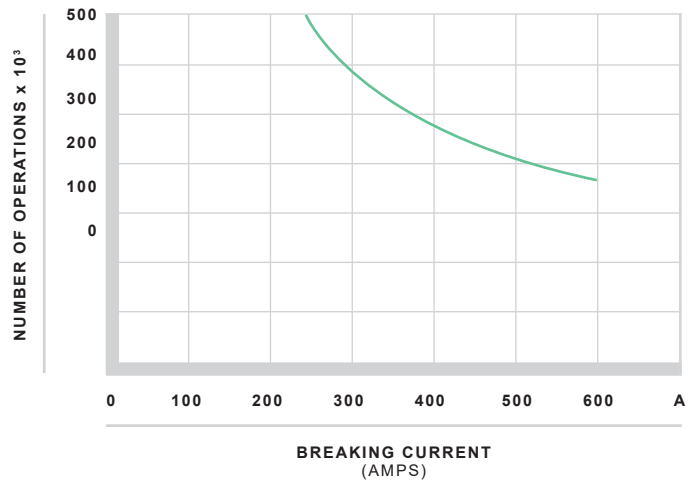

WAUKESHA® UZD® LOAD TAP CHANGER SYSTEM DESIGNED FOR HIGH RELIABILITY AND LOW TOTAL OPERATING COST

- Economical LTC solution to total transformer cost
- Well accepted in the US market
- Now available for sale to transformer manufacturers

Contact us for more information. To download a technical manual, field maintenance manual and/or technical paper, visit our website.

To continually improve its products and services, Prolec-GE Waukesha, Inc., reserves the right to change specifications and features without notice. Please contact us for certified dimensions and drawings.

transformers | service | training | components

© Prolec-GE Waukesha, Inc. | COMP-UZD-1204 (Rev. 04/22)

LOCATION

Prolec-GE Waukesha, Inc.
9011 Governors Row
Dallas, TX 75247
800-338-5526

waukeshacomponents.com



2ND GENERATION

Load Tap Changer Oil Filtration Systems

Reduce Oil-Related Maintenance Costs and Improve Reliability

Second generation oil filtration systems are designed to be installed on most LTC models to remove carbon and metallic particles produced during normal LTC operation, keeping oil in peak condition with minimal maintenance.

For flexible operation, the system includes an adjustable timer which allows customers to configure the system to their specifications — daily, every other day, weekly or every other week in intervals of two, four, eight and 24 hours. Since filter replacement does not require pump reversal or any disconnection of oil lines, the dirty oil stays in the filter while system oil stays clean and in peak condition (a convenient filter canister drain valve is included).

2ND GENERATION OIL FILTRATION SYSTEM: OF2

Easier to Install and Maintain

Our standard OF2 system's design allows for easy installation and is equipped with a swing-out filter canister that makes filter replacements a quicker task.

Unique High-Efficiency Filter Design with Tilt-Out Easy Filter Change System

Our depth-type filter uses a flow path parallel with the center tube instead of the conventional outside-to-inside flow. This flow path forces oil through a greater depth of filter material for more efficient filtration. *See back side for more information on this unique filter design and photo to the right demonstrating easy filter change-out process.*



Minimum Turbulence in Reservoir

Pump maintains a flow rate of 1.0 GPM to minimize turbulence in the tank.

Filter Adapter Kit Available for Alternate Style Manufacturer Cartridges

More Economical

High efficiency filter reduces LTC mechanical wear which can minimize equipment failure and downtime. Economical purchase price combined with less frequent filter replacement can save you money.*

* Actual filter life varies depending on transformer loading and frequency of LTC operations and tap changer model.



Customer Configurable
SEE BACK SIDE FOR PART NUMBER CONFIGURATION TOOL.

CUSTOMIZE YOUR OWN SYSTEM

OF2 oil filtration systems have been designed to meet the filtration demands of higher oil volume load tap changers while providing customization flexibility to meet individual customer specifications. The system is adaptable to a variety of industry standard filters and always ships complete with the following:

- 1/2 HP, fully enclosed, continuous run rated, auto-thermal, resetting motor
- High performance depth filter
- 5+ gallon leak-catch sump with sump alarm
- Low flow alarm
- High pressure alarm
- Anti-condensation cabinet heater
- Tilt-out, tool-free filter change system
- Visual flow indicator which can be monitored without opening the cabinet
- 0-160 psi, oil-filled pressure gauge
- Customer selectable run-time and interval timer
- Run-time bypass switch
- Remote system shutdown relay
- Heavy duty circuit breaker on incoming power
- 120 VAC operation

OPTIONAL FEATURES

- 240 VAC operation
- Alternate filter selection
- Additional 4-20 mA flow transmitter
- Additional 4-20 mA pressure transmitter
- Filter canister heater system
- LTC entrance tube with or without hose
- Stainless steel cabinet

Particle/Moisture removal performance is dependent on make/model of customer-specified oil filter cartridge.

With the appropriate filter installed, the OF2 system can remove dissolved water, extremely fine carbon and metallic particles to maintain peak performance of LTC oil, extend the life of your equipment and lengthen the period between maintenance intervals.

Build Your Own Part Number Using Configuration Below

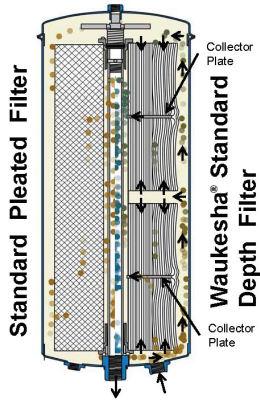
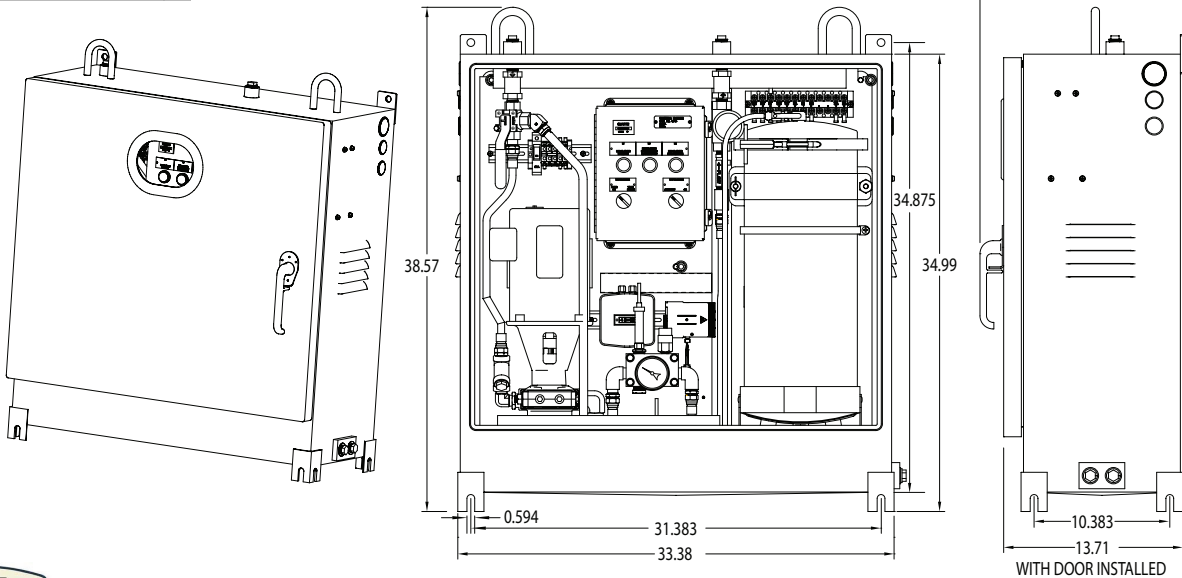
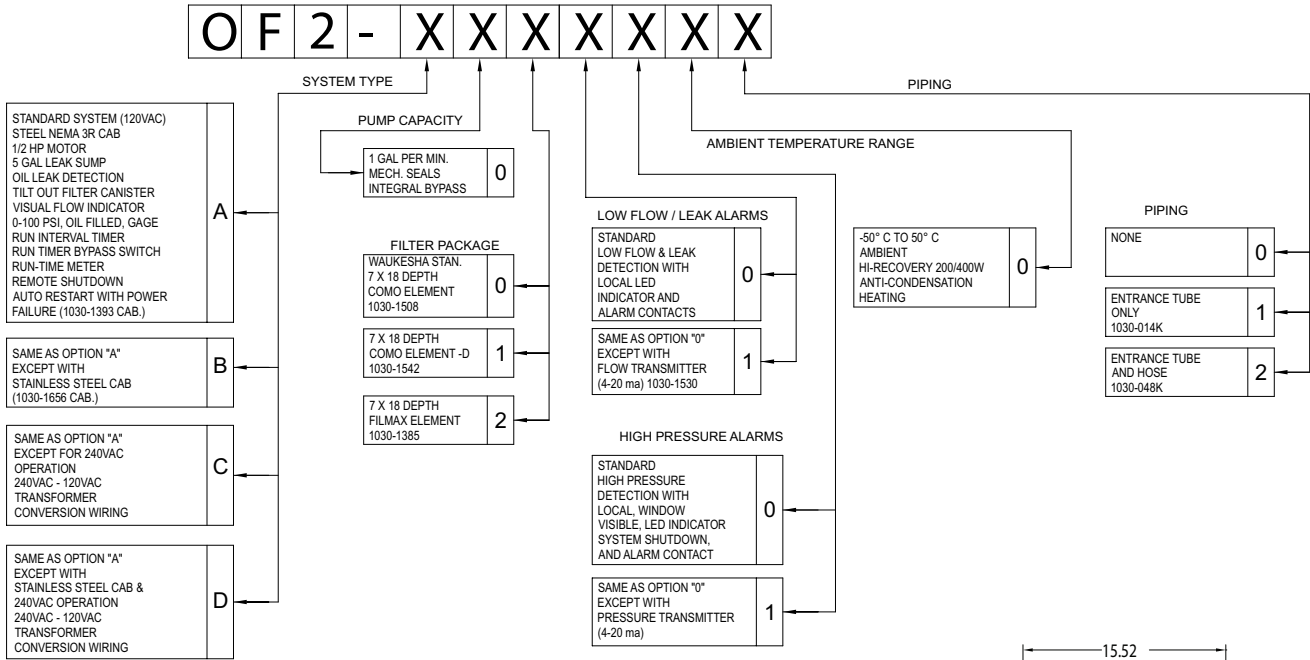

WAUKESHA® STANDARD FILTER OFFERS LONG FILTER ELEMENT LIFE

Waukesha® Components depth-type filter element (in Standard OF2 System) features a unique fluid flow path: fluid runs parallel with the center tube (axial flow) rather than the conventional outside-to-inside flow (radial flow) of most pleated-type filters. The depth of fluid flow is optimized and provides the capability to filter more efficiently than pleated-type filters. Filter media is constructed as four rolls of filter paper. Oil flows between the layers of media until it reaches one of two collector plates. The collector plates route oil to the center of the element where it is discharged out of the element. The depth filter media has a much greater resistance to flow from outside to center (radial flow) than it does between the layers (axial flow) of filter material. Integrity of the filter element is maintained even as it accumulates contaminants and the Delta-p [pressure across the filter] goes up. Hydraulic pressure of the fluid compressing the layers of media together prevents a channel from forming that could allow oil to pass through the element unfiltered.

Removes Both Dirt and Moisture

- Filter material: Dried cellulose fiber
- Filter can decrease water to < 5 PPM
- Micron rating: 1.0; rated for particulates as well as free and emulsified water
- Beta X rating: 75 at 3 microns
- Total water holding capacity: 0.5 kg
- High rate of absorption enables oil to be reduced from 200 to less than 5 PPM in one pass

Contact us for more information. To download a technical manual, field maintenance manual and/or technical paper, visit our website.

To continually improve its products and services, Prolec-GE Waukesha, Inc., reserves the right to change specifications and features without notice. Please contact us for certified dimensions and drawings.

LOCATION
 Prolec-GE Waukesha, Inc.
 9011 Governors Row
 Dallas, TX 75247
 800-338-5526

waukeshacomponents.com

transformers | service | training | components





Formal Bid and Award System

Award #3 August 25, 2022

Type of Award Request: REQUEST FOR PROPOSAL (RFP)
Requestor Name: Summers, Matt K. - Manager Physical Security
Requestor Phone: (904) 665-4798
Project Title: Fire Extinguisher Services for JEA
Project Number: HE31000
Project Location: JEA
Funds: O&M
Award Estimate: \$887,000.00

Scope of Work:

The Company (also referred to as “Contractor”) shall inspect and test all portable fire extinguishers at the locations identified throughout the service territory of the governing organization. All portable fire extinguishers will be inspected and maintained on an annual and six-year basis; however, the governing organization may identify certain locations that will require monthly or weekly inspections. These services shall be conducted in accordance with the applicable governing publications and regulations.

JEA IFB/RFP/State/City/GSA#: 1410788446
Purchasing Agent: Lovgren, Rodney Dennis
Is this a Ratification?: NO

RECOMMENDED AWARDEE(S):

Name	Contact Name	Email	Address	Phone	JEA Amount
MILTON J. WOOD FIRE PROTECTION, INC.	Shane Shepperd	sshepperd@mjwood.com	3805 Faye Rd. Jacksonville, FL 32226	904-353-5527	\$704,658.50

Amount for entire term of Contract/PO: \$704,658.50
Award Amount for remainder of this FY: \$0.00
Length of Contract/PO Term: Five (5) Years w/Two (2) – 1 Yr. Renewals
Begin Date (mm/dd/yyyy): 10/01/2022
End Date (mm/dd/yyyy): 09/30/2027
Renewal Options: YES – Two (2) – 1 Yr. Renewals
JSEB Requirement: JSEB Optional

BIDDERS:

Name	Total Bid Amount
MILTON J. WOOD FIRE PROTECTION, INC.	\$704,658.50
FIRE AND LIFE SAFETY	\$1,203,774.00

CINTAS	\$1,790,135.00
--------	----------------

Background/Recommendations:

Advertised 07/07/2022. An optional pre-proposal meeting was held on 07/12/2022. At Proposal opening on 07/26/2022, JEA received three (3) Proposals. Companies were evaluated 100% on price. Milton J. Wood Fire Protection, Inc. is the aggregate lowest price company for the services required and has the lowest billable rates. A copy of the Proposal Form and Rates Workbook is attached as back-up.

When comparing the incumbent current contract pricing with the new contract price, JEA’s estimated spend forecast increase over the five-year term is \$332,879.55, or an approximate ninety percent (90%) increase. The FY23 O&M budget for these services will be adjusted if needed to accommodate the increase in rates. The price comparison spreadsheet is attached as back-up.

After receiving priced proposals, JEA reviewed the unit pricing and noted the monthly and annual inspections as an area where costs increased significantly, along with specific chemical agent requirements. JEA had discussions with both the incumbent (Cintas) and the awardee (MJ Wood) and had determined that the historical pricing is not in line with market conditions. The incumbent noted their previous bid per unit inspection prices did not account for a technician to drive across JEA’s territory to inspect 2 or 3 extinguishers at a remote location, resulting their current contract losing money. As such Cintas’s new pricing was reflective of what Cintas believed they needed in the cost structure to meet margin requirements. The awardee noted, unit prices cover their direct and indirect costs with a reasonable mark up for what MJ Wood believes the work will take, stating distance and grouping of inspections are a cost driver. MJ Wood also noted that chemical agents, specifically PK and FE-36 are experiencing significant price fluctuations. Based on the communications with the supply base, a reasonable demonstration of competition, via public bid pricing is deemed reasonable and consistent with market conditions.

1410788446 – Request approval to award a five (5) year contract to Milton J. Wood Fire Protection, Inc. for Fire Extinguisher Services for JEA in the amount of \$704,658.50, subject to the availability of lawfully appropriated funds.

Director: Edwards, Brandon L. - Director Security & Emergency Preparedness

VP: McElroy, Alan D. - VP Supply Chain & Operations Support

APPROVALS:

Stephen Datz 8/25/2022

Chairman, Awards Committee **Date**

Stephanie M Healy 8/25/2022

Budget Representative **Date**

000-00
APPENDIX B BID WORKBOOK
INSPECTION AND MAINTENANCE OF FIRE EXTINGUISHERS

Company:	Milton J Wood Fire Protection
Contact:	Shane Shepperd
Phone No.:	904-353-5527

1. Inspection, Maintenance, and Testing Services - The rates the contractor estimates below must be inclusive of all required material, labor, and equipment necessary to properly perform the services outlined in the technical specifications. These quantities are estimated and are for evaluation purposes and are not a guarantee of future business.

All Generating Stations						
Agent	Type	Unit Cost	Frequency	Unit Total	Est. # Units	Total
Stored Pressure	Monthly	\$ 3.50	55	\$ 192.50	603	\$ 116,077.50
	Annual	\$ 6.50	5	\$ 32.50	603	\$ 19,597.50
	6-Year	\$ 15.00	1	\$ 15.00	603	\$ 9,045.00
Stored Pressure	Monthly	\$ 3.50	55	\$ 192.50	17	\$ 3,272.50
	Annual	\$ 6.50	5	\$ 32.50	17	\$ 552.50
	6-Year	\$ 15.00	1	\$ 15.00	17	\$ 255.00
CO2	Monthly	\$ 3.50	55	\$ 192.50	140	\$ 26,950.00
	Annual	\$ 6.50	5	\$ 32.50	140	\$ 4,550.00
	6-Year	\$ 25.00	1	\$ 25.00	140	\$ 3,500.00
Wheeled Unit	Monthly	\$ 3.50	55	\$ 192.50	22	\$ 4,235.00
	Annual	\$ 10.50	5	\$ 52.50	22	\$ 1,155.00
	6-Year	\$ 300.00	1	\$ 300.00	22	\$ 6,600.00
Wheeled Unit w/Nitrogen	Monthly	\$ 3.50	55	\$ 192.50	3	\$ 577.50
	Annual	\$ 65.00	5	\$ 325.00	3	\$ 975.00
	6-Year	\$ 375.00	1	\$ 375.00	3	\$ 1,125.00
Subtotal:						\$ 198,467.50

All Other JEA Sites						
Agent	Type	Unit Cost	Frequency	Unit Total	Est. # Units	Total
Stored Pressure	Annual	\$ 6.50	5	\$ 32.50	1346	\$ 43,745.00
	6-Year	\$ 15.00	1	\$ 15.00	1346	\$ 20,190.00
Cartridge Operated	Annual	\$ 12.00	5	\$ 60.00	19	\$ 1,140.00
	6-Year	\$ 95.00	1	\$ 95.00	19	\$ 1,805.00
CO2	Annual	\$ 6.50	5	\$ 32.50	352	\$ 11,440.00
	6-Year	\$ 25.00	1	\$ 25.00	352	\$ 8,800.00
Wheeled Unit	Annual	\$ 10.50	5	\$ 52.50	4	\$ 210.00
	6-Year	\$ 300.00	1	\$ 300.00	4	\$ 1,200.00
Kitchen Suppression System	Semi-Annual	\$ 175.00	10	\$ 1,750.00	2	\$ 3,500.00
	Hydrostatic	\$ 87.00	1	\$ 87.00	3	\$ 261.00
Subtotal:						\$ 92,291.00

Fleet Service Centers						
Agent	Type	Unit Cost	Frequency	Unit Total	Est. # Units	Total
Stored Pressure	Annual	\$ 6.50	5	\$ 32.50	2400	\$ 78,000.00
	6-Year	\$ 15.00	1	\$ 15.00	2400	\$ 36,000.00
Subtotal:						\$ 114,000.00

Line #1 Total: \$ 404,758.50

XXX-21
APPENDIX B BID WORKBOOK
INSPECTION AND MAINTENANCE OF FIRE EXTINGUISHERS

Company: Milton J Wood Fire Protection
Contact: Shane Shepperd
Phone No.: 904-353-5527

2. Fire Extinguisher Materials - The rates the contractor estimates below must be inclusive of all required material, shipping, delivery, and associated charges required to properly perform the services outlined in the technical specifications. These material rates will be used for providing additional devices for stock or replacing units that are damaged or obsolete. These quantities are estimated and are for evaluation purposes and are not a guarantee of future business.

Fire Extinguisher Materials			
Type	Unit Cost	Est. # Units	Total
5# ABC Extinguisher	\$ 65.00	50	\$ 3,250.00
10# ABC Extinguisher	\$ 98.00	25	\$ 2,450.00
20# ABC Extinguisher	\$ 165.00	15	\$ 2,475.00
5# Purple K Extinguisher	\$ 75.00	500	\$ 37,500.00
20# Purple K Extinguisher	\$ 215.00	15	\$ 3,225.00
10# CO2 Extinguisher	\$ 275.00	15	\$ 4,125.00
20# CO2 Extinguisher	\$ 389.00	50	\$ 19,450.00
6L K-Class	\$ 215.00	1	\$ 215.00
2.5 Gal H2O/Water Mist	\$ 239.00	5	\$ 1,195.00
15.5# FE36	\$ 1,287.00	100	\$ 128,700.00
2.5 Gal AR-AFFF	\$ 100.00	10	\$ 1,000.00
150# Purple K Wheeled Unit	\$ 3,495.00	5	\$ 17,475.00
Subtotal:			\$ 221,060.00

3. Fire Extinguisher Installation and Signage - The rates the contractor estimates below must be inclusive of all required material and labor required to properly perform the services outlined in the technical specifications. These rates will be used for installing new devices, not replacing an existing device. The total price for the installation of the new unit will be the below labor rate plus the applicable above material charge. These quantities are estimated and are for evaluation purposes and are not a guarantee of future business.

Fire Extinguisher Installation and Signage			
Type	Unit Cost	Est. # Units	Total
Labor and Signage	\$ 65.00	100	\$ 6,500.00
Subtotal:			\$ 6,500.00

4. Fire Extinguisher Recharges from Discharge - The rates the contractor estimates below must be inclusive of all required material and labor required to properly perform the services outlined in the technical specifications. These rates will include replacement of missing, or broken, locking pins, seals, valve stems, O rings, and verification collars. These quantities are estimated and are for evaluation purposes and are not a guarantee of future business.

Fire Extinguisher Recharge from Discharge			
Type	Unit Cost	Est. # Units	Total
5lb Dry Chemical	\$ 15.00	250	\$ 3,750.00
10lb Dry Chemical	\$ 20.00	50	\$ 1,000.00
20lb Dry Chemical	\$ 30.00	50	\$ 1,500.00
5lb Purple K	\$ 15.00	250	\$ 3,750.00
10lb Purple K	\$ 20.00	25	\$ 500.00
20lb Purple K	\$ 30.00	50	\$ 1,500.00
20lb Purple K (Cartridge Operated)	\$ 75.00	250	\$ 18,750.00
150lb Purple K (Wheeled Units)	\$ 300.00	5	\$ 1,500.00
5lb CO2	\$ 25.00	5	\$ 125.00
10lb CO2	\$ 35.00	5	\$ 175.00
15lb CO2	\$ 45.00	5	\$ 225.00
20lb CO2	\$ 65.00	25	\$ 1,625.00
2.5gal AFFF	\$ 10.00	25	\$ 250.00
2.5gal AR-AFFF	\$ 10.00	25	\$ 250.00
2.5gal Water Mist	\$ 30.00	25	\$ 750.00
6 liter K-Class Wet Chemical	\$ 95.00	2	\$ 190.00
FE36 per pound	\$ 50.00	250	\$ 12,500.00
Subtotal:			\$ 48,340.00

5. Other Material Markup Percentage - The percentage the contractor enters below will be used as the markup limitation for all other materials procured under this contract in accordance with the requirements of the technical specification.

Other Material Markup Percentage - Not to Exceed 30%			
Type	Base Amount	%	Total
Other Material Markup Percentage	\$ 20,000.00	20%	\$ 24,000.00
Subtotal:			\$ 24,000.00

Line #2 Total: \$ 299,900.00

Inspection and Maintenance of Fire Extinguishers

Appendix B Response Form

Submit the Response an electronic pdf in accordance with the procedures in the solicitation.

Company Name: Milton J. Ward Fire Protection

Company's Address: 3805 Faye Rd.

License Number: FED21-000026

Phone Number: 904-353-5527 Email Address: SSheppard@mjward.com

BID SECURITY REQUIREMENTS <input checked="" type="checkbox"/> None required <input type="checkbox"/> Certified Check or Bond Five Percent (5%)	TERM OF CONTRACT <input type="checkbox"/> One Time Purchase <input checked="" type="checkbox"/> Term - Five (5) Years w/Two (2) – 1Yr Renewals <input type="checkbox"/> Other, Specify - Project Completion
---	---

SAMPLE REQUIREMENTS <input checked="" type="checkbox"/> None required <input type="checkbox"/> Samples required prior to Bid Opening <input type="checkbox"/> Samples may be required subsequent to Bid Opening	SECTION 255.05, FLORIDA STATUTES CONTRACT BOND <input checked="" type="checkbox"/> None required <input type="checkbox"/> Bond required 100% of Bid Award
---	--

QUANTITIES REQUIREMENTS <input type="checkbox"/> Quantities indicated are exacting <input checked="" type="checkbox"/> Quantities indicated reflect the approximate quantities to be purchased Throughout the Contract period and are subject to fluctuation in accordance with actual requirements.	INSURANCE <p align="center">Insurance required</p>
---	---

PAYMENT DISCOUNTS
 1% 20, net 30
 2% 10, net 30
 Other _____
 None Offered

Item No.	ENTER YOUR BID FOR THE FOLLOWING DESCRIBED ARTICLES OR SERVICES:	TOTAL BID PRICE
3	Total Bid Price – From the Bid Workbook	\$ <u>704,658.⁵⁰</u>

I have read and understood the Sunshine Law/Public Records clauses contained within this solicitation. I understand that in the absence of a redacted copy my proposal will be disclosed to the public "as-is".

BIDDER CERTIFICATION

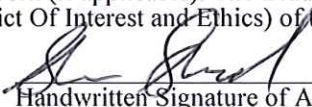
By submitting this Bid, the Bidder certifies that it has read and reviewed all of the documents pertaining to this Solicitation, that the person signing below is an authorized representative of the Bidding Company, that the Company is legally authorized to do business in the State of Florida, and that the Company maintains in active status an appropriate contractor's license for the work (if applicable). The Bidder also certifies that it complies with all sections (including but not limited to Conflict Of Interest and Ethics) of this Solicitation.	
We have received addenda Date _____ through <u>None</u>	 _____ Handwritten Signature of Authorized Officer of Company or Agent
	<u>Shane Sheppard</u> <u>Project Manager</u> Printed Name and Title

Inspection and Maintenance of Fire Extinguishers

Appendix B - Minimum Qualification Form

GENERAL

THE MINIMUM QUALIFICATIONS SHALL BE SUBMITTED ON THIS FORM. IN ORDER TO BE CONSIDERED A QUALIFIED RESPONDENT BY JEA YOU MUST MEET THE MINIMUM QUALIFICATIONS LISTED BELOW, AND BE ABLE TO PROVIDE ALL THE SERVICES LISTED IN THIS SOLICITATION/TECHNICAL SPECIFICATION.

THE RESPONDENT MUST COMPLETE THE RESPONDENT INFORMATION SECTION BELOW AND PROVIDE ANY OTHER INFORMATION OR REFERENCE REQUESTED. THE RESPONDENT MUST ALSO PROVIDE ANY ATTACHMENTS REQUESTED WITH THIS MINIMUM QUALIFICATIONS FORM.

PLEASE SUBMIT A PDF COPY FORM AND ANY REQUESTED ADDITIONAL DOCUMENTATION WITH THE BID SUBMISSION.

RESPONDENT INFORMATION

COMPANY NAME: Milton J Ward Fire Protection

BUSINESS ADDRESS: 3805 Faye Rd.

CITY, STATE, ZIP CODE: Jacksonville, FL 32226

TELEPHONE: 904-353-5527

FAX: _____

E-MAIL: Ssheppard@mjward.com

PRINT NAME OF AUTHORIZED REPRESENTATIVE: Shane Sheppard

SIGNATURE OF AUTHORIZED REPRESENTATIVE: [Signature]

NAME AND TITLE OF AUTHORIZED REPRESENTATIVE: Project Manager

MINIMUM QUALIFICATIONS:

- 1) Bidder shall have an office that is located within one of the following counties: Duval, Nassau, Clay or St Johns. – Enter address where indicated below.
- 2) Bidder shall be licensed by the State of Florida with a Class A License to perform all required inspections, repair and testing services for all manufacturer models of Ansul, Amerex, Buckeye, and Kidde. The primary extinguishing agents are: PKP, CO2, AFFF, Halon 1211/1301, Class ABC Dry Chemical, and Energin. – Enter license number where indicated below.
- 3) Bidder shall provide certification, or letter from the manufacturer, to sell all manufacturer models of Ansul, Amerex, Buckeye, and Kidde. The primary extinguishing agents are: PKP, CO2, AFFF, Halon 1211/1301, Class ABC Dry Chemical, and Energin. – Enter certification number or attach letter where indicated below.
- 4) Bidder must have successfully completed at least one (1) commercial fire extinguisher inspection and maintenance contract, valued at least \$50,000 or greater per year of the contract, during the last five (5) years ending April 30, 2022. – Enter solicited information where indicated below.

Inspection and Maintenance of Fire Extinguishers

Appendix B - Minimum Qualification Form

1) PROPOSED OFFICE LOCATION TO SERVE JEA

Office Address 3805 Faye Rd.
County of Office Location Duval

2) BIDDER'S STATE OF FLORIDA LICENSE NUMBER TO PERFORM ALL INSPECTIONS, REPAIR, AND TESTING SERVICES FOR ALL MANUFACTURER MODELS OF ANSUL, AMEREX, BUCKEYE, AND KIDDE.

State of Florida License Number FED21-000026

3) BIDDER'S CERTIFICATION OR LETTER FROM THE MANUFACTURER TO SELL ALL MANUFACTURER MODELS OF ANSUL, AMEREX, BUCKEYE, AND KIDDE. THE PRIMARY EXTINGUISHING AGENTS ARE: PKP, CO2, AFFF, Halon 1211/1301, Class ABC Dry Chemical, and Energin.

Bidder's Certification or (attach) Letter from the Manufacturer License Attached

4) COMMERCIAL FIRE EXTINGUISHER AND MAINTENANCE CONTRACT

Client Name GP Palatka
Client Contact Name and Title Matt Robinson Safety Specialist
Client Contact Phone Number Matt Robinson 386-546-5637
Client Contact Email Address Matthew.Robinson@gapac.com
Annual Value of Contract \$60,375.⁰⁰
Contract Effective Date 3-8-2022
Contract End Date 12-31-2022

Brief Description of Scope and Services included in the Contract

Monthly and Annual maintenance + Inspections for specified
JEA locations.

Inspection and Maintenance of Fire Extinguishers

LIST OF SUBCONTRACTORS

JEA Solicitation Number ~~410788446~~ requires certain major Subcontractors be listed on this form, unless the work will be self-performed by the Company.

The undersigned understands that failure to submit the required Subcontractor information on this form will result in bid rejection, and the Company agrees to employ the Subcontractors specified below: (Use additional sheets as necessary)

Note: This list of Subcontractors shall not be modified subsequent to bid opening, without a showing of good cause and the written consent of JEA.

Type of Work	Corporate Name of Subcontractor	Subcontractor Primary Contact Person & Telephone Number	Subcontractor's License Number (if applicable)	Percentage of Work or Dollar Amount
Kitchen Hood Inspection	Fire Master	Kevin Carter 904-426-8489	FED18-000065	\$3,761

Signed:  _____

Company: Milton J Wood Fire Protection

Address: 3805 Faye Rd.

Inspection and Maintenance of Fire Extinguishers

Date: _____

LIST OF JSEB SUBCONTRACTORS

The following JSEB Subcontractors will be utilized in fulfilling the terms and conditions of a Project Authorization arising from award of JEA - _____. I (We) the undersigned understand that failure to submit said information will result in bid rejection. I (We) will employ the JSEB Subcontractors specified below: (Use additional sheets as necessary)

Class of Work (Category) Dollar Amount	Name of JSEB Contractor (Indicate below)	Percentage of Total Job or
---	---	----------------------------

Signed: _____

Company: _____

Address: _____

Date: _____

Inspection and Maintenance of Fire Extinguishers

Note: This list shall not be modified subsequent to bid opening without a showing of good cause and the written consent of the JEA.

Jimmy Patronis
CHIEF FINANCIAL OFFICER
Julius Halas
DIVISION DIRECTOR



John Gatlin
BUREAU CHIEF

FLORIDA DEPARTMENT OF FINANCIAL SERVICES
DIVISION OF STATE FIRE MARSHAL
200 EAST GAINES STREET - Tallahassee, Florida 32399-0342
Tel. 850-413-3644

FIRE EQUIPMENT DEALER LICENSE
OFFICIAL COPY

THIS CERTIFIES THAT: Milton J. Wood Fire Protection, Inc.
3805 Faye Road
Jacksonville FL 32226

QUALIFIER: Robert S. Shepperd

Has Complied with Florida statutes and has qualified for the type and class shown here on to service, recharge, repair, install, or inspect all types of Fire Extinguishers including recharging carbon dioxide units, and to conduct hydrostatic tests on all types of fire extinguishers including carbon Dioxide Units.

Issue Date: 01/01/2022
Type: 07
Class: 01
County: Duval
License/Permit #: FED21-000026
Expiration Date: 12/31/2023



Handwritten signature of Jimmy Patronis in cursive.

Chief Financial Officer



CERTIFICATE OF LIABILITY INSURANCE

DATE (MM/DD/YYYY)

1/26/2022

THIS CERTIFICATE IS ISSUED AS A MATTER OF INFORMATION ONLY AND CONFERS NO RIGHTS UPON THE CERTIFICATE HOLDER. THIS CERTIFICATE DOES NOT AFFIRMATIVELY OR NEGATIVELY AMEND, EXTEND OR ALTER THE COVERAGE AFFORDED BY THE POLICIES BELOW. THIS CERTIFICATE OF INSURANCE DOES NOT CONSTITUTE A CONTRACT BETWEEN THE ISSUING INSURER(S), AUTHORIZED REPRESENTATIVE OR PRODUCER, AND THE CERTIFICATE HOLDER.

IMPORTANT: If the certificate holder is an ADDITIONAL INSURED, the policy(ies) must have ADDITIONAL INSURED provisions or be endorsed. If SUBROGATION IS WAIVED, subject to the terms and conditions of the policy, certain policies may require an endorsement. A statement on this certificate does not confer rights to the certificate holder in lieu of such endorsement(s).

PRODUCER Arthur J. Gallagher Risk Management Services, Inc. 501 Riverside Ave Suite 1000 Jacksonville FL 32202		CONTACT NAME: PHONE (A/C, No, Ext): 904-354-3785 FAX (A/C, No): 904-634-1302 E-MAIL ADDRESS: info@hardeninsight.com	
INSURED Milton J. Wood Fire Protection, Inc. 3805 Faye Rd Jacksonville FL 32226		INSURER(S) AFFORDING COVERAGE	
		INSURER A : AMERICAN ZURICH INS CO	
		INSURER B : NAVIGATORS SPECIALTY INS CO	
		INSURER C : Lexington Insurance Company	
		INSURER D : Accredited Specialty Insurance Company	
		INSURER E : Allied World Specialty Insurance Company (f/k/a Da	
		INSURER F : Liberty Insurance Corporation	

COVERAGES **CERTIFICATE NUMBER: 966393098** **REVISION NUMBER:**

THIS IS TO CERTIFY THAT THE POLICIES OF INSURANCE LISTED BELOW HAVE BEEN ISSUED TO THE INSURED NAMED ABOVE FOR THE POLICY PERIOD INDICATED. NOTWITHSTANDING ANY REQUIREMENT, TERM OR CONDITION OF ANY CONTRACT OR OTHER DOCUMENT WITH RESPECT TO WHICH THIS CERTIFICATE MAY BE ISSUED OR MAY PERTAIN, THE INSURANCE AFFORDED BY THE POLICIES DESCRIBED HEREIN IS SUBJECT TO ALL THE TERMS, EXCLUSIONS AND CONDITIONS OF SUCH POLICIES. LIMITS SHOWN MAY HAVE BEEN REDUCED BY PAID CLAIMS.

INSR LTR	TYPE OF INSURANCE	ADDL INSD	SUBR WVD	POLICY NUMBER	POLICY EFF (MM/DD/YYYY)	POLICY EXP (MM/DD/YYYY)	LIMITS	
A	<input checked="" type="checkbox"/> COMMERCIAL GENERAL LIABILITY <input type="checkbox"/> CLAIMS-MADE <input checked="" type="checkbox"/> OCCUR <input checked="" type="checkbox"/> Blnkt Addl Insd. <input checked="" type="checkbox"/> Blnkt WOS GEN'L AGGREGATE LIMIT APPLIES PER: <input type="checkbox"/> POLICY <input checked="" type="checkbox"/> PROJECT <input type="checkbox"/> LOC <input checked="" type="checkbox"/> OTHER: Blnkt PNC			GLO712296300	10/1/2021	10/1/2022	EACH OCCURRENCE	\$ 2,000,000
							DAMAGE TO RENTED PREMISES (Ea occurrence)	\$ 100,000
							MED EXP (Any one person)	\$ 10,000
							PERSONAL & ADV INJURY	\$ 2,000,000
							GENERAL AGGREGATE	\$ 4,000,000
							PRODUCTS - COMP/OP AGG	\$ 4,000,000
								\$
A	AUTOMOBILE LIABILITY <input checked="" type="checkbox"/> ANY AUTO <input checked="" type="checkbox"/> OWNED AUTOS ONLY <input checked="" type="checkbox"/> HIRED AUTOS ONLY <input type="checkbox"/> SCHEDULED AUTOS <input checked="" type="checkbox"/> NON-OWNED AUTOS ONLY			BAP698719300	10/1/2021	10/1/2022	COMBINED SINGLE LIMIT (Ea accident)	\$ 1,000,000
							BODILY INJURY (Per person)	\$
							BODILY INJURY (Per accident)	\$
							PROPERTY DAMAGE (Per accident)	\$
								\$
B	UMBRELLA LIAB <input checked="" type="checkbox"/> OCCUR EXCESS LIAB <input type="checkbox"/> CLAIMS-MADE DED RETENTION \$			GA21EXCZ02TMFIC	10/1/2021	10/1/2022	EACH OCCURRENCE	\$ 15,000,000
							AGGREGATE	\$ 15,000,000
								\$ see comments
F	WORKERS COMPENSATION AND EMPLOYERS' LIABILITY ANY PROPRIETOR/PARTNER/EXECUTIVE OFFICER/MEMBER EXCLUDED? (Mandatory in NH) If yes, describe under DESCRIPTION OF OPERATIONS below	Y/N	N/A	WC2651294195011 WCEW565N294195021	10/1/2021 10/1/2021	10/1/2022 10/1/2022	PER STATUTE	
							E.L. EACH ACCIDENT	\$ 1,000,000
							E.L. DISEASE - EA EMPLOYEE	\$ 1,000,000
							E.L. DISEASE - POLICY LIMIT	\$ 1,000,000
C	Pollution/Professional Liability Cyber Liability Employment Practices			028395960	10/1/2021	10/1/2022	Occ/Agg	5,000,000
D				2CIAFL17S3024293-00	10/1/2021	10/1/2022	Occ/Agg	5,000,000
E				03078638	10/1/2021	10/1/2022	Occ	1,000,000

DESCRIPTION OF OPERATIONS / LOCATIONS / VEHICLES (ACORD 101, Additional Remarks Schedule, may be attached if more space is required)
 General Liability - XCU Included, Contractual Liability Included.

Excess:
 Primary Excess - \$5,000,000 - Navigators Specialty - Policy Number GA21EXCZ02TMFIC - 10/01/21-22
 2nd Excess - \$5,000,000 - Indian Harbor Insurance Company - Policy Number SXS0059990 - 10/01/21-22
 3rd Excess - \$5,000,000 - Endurance American Specialty - Policy Number ELD30001268902 - 10/01/21-22

Installation - \$2,000,000 - \$1,000,000 Temporary Site - \$500,000 Transit - Charter Oak Fire Ins. Co. - Policy Number QT6305N319024TIL21 - 10/01/21-22
 See Attached...

CERTIFICATE HOLDER**CANCELLATION**

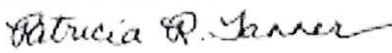
JEA 21 W. Church Street Jacksonville FL 32202	SHOULD ANY OF THE ABOVE DESCRIBED POLICIES BE CANCELLED BEFORE THE EXPIRATION DATE THEREOF, NOTICE WILL BE DELIVERED IN ACCORDANCE WITH THE POLICY PROVISIONS. AUTHORIZED REPRESENTATIVE 
---	---

© 1988-2015 ACORD CORPORATION. All rights reserved.



ADDITIONAL REMARKS SCHEDULE

AGENCY Arthur J. Gallagher Risk Management Services, Inc.		NAMED INSURED Milton J. Wood Fire Protection, Inc. 3805 Faye Rd Jacksonville FL 32226	
POLICY NUMBER		EFFECTIVE DATE:	
CARRIER	NAIC CODE		

ADDITIONAL REMARKS

THIS ADDITIONAL REMARKS FORM IS A SCHEDULE TO ACORD FORM,
 FORM NUMBER: 25 FORM TITLE: CERTIFICATE OF LIABILITY INSURANCE

Riggers Liability - \$2,000,000 - \$1,000,000 Temporary Site - \$500,000 Transit - Charter Oak Fire Ins. Co. - Policy Number QT6305N319024TIL21 - 10/01/21-22
 Leased or Rented Any One Item - \$1,000,000 - Charter Oak Fire Ins. Co. - Policy Number QT6305N319024TIL21 - 10/01/21-22
 Certificate holder, its board members, officers, employees, agents, successors and assigns are named as additional insured with respect to General Liability, Auto Liability, Excess Liability and completed operations for work being performed by the named insured for the certificate holder. Coverage afforded the additional insured shall be primary and noncontributory to any other insurance afforded the additional insured. A Waiver of Subrogation in favor of additional insured applies to all policies shown above.

Request for Taxpayer Identification Number and Certification

Give Form to the
requester. Do not
send to the IRS.

▶ Go to www.irs.gov/FormW9 for instructions and the latest information.

Print or type. See Specific Instructions on page 3.	1 Name (as shown on your income tax return). Name is required on this line; do not leave this line blank. Milton J Wood Fire Protection, Inc.	
	2 Business name/disregarded entity name, if different from above	
	3 Check appropriate box for federal tax classification of the person whose name is entered on line 1. Check only one of the following seven boxes.	4 Exemptions (codes apply only to certain entities, not individuals; see instructions on page 3):
	<input type="checkbox"/> Individual/sole proprietor or single-member LLC	Exempt payee code (if any) _____ Exemption from FATCA reporting code (if any) _____ <i>(Applies to accounts maintained outside the U.S.)</i>
	<input type="checkbox"/> C Corporation	
	<input checked="" type="checkbox"/> S Corporation	
	<input type="checkbox"/> Partnership	
	<input type="checkbox"/> Trust/estate	
	<input type="checkbox"/> Limited liability company. Enter the tax classification (C=C corporation, S=S corporation, P=Partnership) ▶ _____ Note: Check the appropriate box in the line above for the tax classification of the single-member owner. Do not check LLC if the LLC is classified as a single-member LLC that is disregarded from the owner unless the owner of the LLC is another LLC that is not disregarded from the owner for U.S. federal tax purposes. Otherwise, a single-member LLC that is disregarded from the owner should check the appropriate box for the tax classification of its owner.	
	<input type="checkbox"/> Other (see instructions) ▶ _____	
	5 Address (number, street, and apt. or suite no.) See instructions. 3805 Faye Road	Requester's name and address (optional) JEA 21 W. Church Street Jacksonville, FL 32202
	6 City, state, and ZIP code Jacksonville, FL 32226	
	7 List account number(s) here (optional)	

Part I Taxpayer Identification Number (TIN)	
Enter your TIN in the appropriate box. The TIN provided must match the name given on line 1 to avoid backup withholding. For individuals, this is generally your social security number (SSN). However, for a resident alien, sole proprietor, or disregarded entity, see the instructions for Part I, later. For other entities, it is your employer identification number (EIN). If you do not have a number, see <i>How to get a TIN</i> , later.	
	Social security number [] [] [] - [] [] - [] [] [] [] or Employer identification number 5 9 - 3 0 5 5 3 0 3
Note: If the account is in more than one name, see the instructions for line 1. Also see <i>What Name and Number To Give the Requester</i> for guidelines on whose number to enter.	

Part II Certification	
Under penalties of perjury, I certify that:	
1. The number shown on this form is my correct taxpayer identification number (or I am waiting for a number to be issued to me); and	
2. I am not subject to backup withholding because: (a) I am exempt from backup withholding, or (b) I have not been notified by the Internal Revenue Service (IRS) that I am subject to backup withholding as a result of a failure to report all interest or dividends, or (c) the IRS has notified me that I am no longer subject to backup withholding; and	
3. I am a U.S. citizen or other U.S. person (defined below); and	
4. The FATCA code(s) entered on this form (if any) indicating that I am exempt from FATCA reporting is correct.	
Certification instructions. You must cross out item 2 above if you have been notified by the IRS that you are currently subject to backup withholding because you have failed to report all interest and dividends on your tax return. For real estate transactions, item 2 does not apply. For mortgage interest paid, acquisition or abandonment of secured property, cancellation of debt, contributions to an individual retirement arrangement (IRA), and generally, payments other than interest and dividends, you are not required to sign the certification, but you must provide your correct TIN. See the instructions for Part II, later.	

Sign Here	Signature of U.S. person ▶ <i>Pam Rhoda</i>	Date ▶ <i>7-25-22</i>
------------------	---	-----------------------

General Instructions

Section references are to the Internal Revenue Code unless otherwise noted.

Future developments. For the latest information about developments related to Form W-9 and its instructions, such as legislation enacted after they were published, go to www.irs.gov/FormW9.

Purpose of Form

An individual or entity (Form W-9 requester) who is required to file an information return with the IRS must obtain your correct taxpayer identification number (TIN) which may be your social security number (SSN), individual taxpayer identification number (ITIN), adoption taxpayer identification number (ATIN), or employer identification number (EIN), to report on an information return the amount paid to you, or other amount reportable on an information return. Examples of information returns include, but are not limited to, the following.

- Form 1099-INT (interest earned or paid)

- Form 1099-DIV (dividends, including those from stocks or mutual funds)
- Form 1099-MISC (various types of income, prizes, awards, or gross proceeds)
- Form 1099-B (stock or mutual fund sales and certain other transactions by brokers)
- Form 1099-S (proceeds from real estate transactions)
- Form 1099-K (merchant card and third party network transactions)
- Form 1098 (home mortgage interest), 1098-E (student loan interest), 1098-T (tuition)
- Form 1099-C (canceled debt)
- Form 1099-A (acquisition or abandonment of secured property)
Use Form W-9 only if you are a U.S. person (including a resident alien), to provide your correct TIN.
If you do not return Form W-9 to the requester with a TIN, you might be subject to backup withholding. See What is backup withholding, later.



[Department of State](#) / [Division of Corporations](#) / [Search Records](#) / [Search by Entity Name](#) /

Detail by Entity Name

Florida Profit Corporation

MILTON J. WOOD FIRE PROTECTION, INC.

Filing Information

Document Number S39832
FEI/EIN Number 59-3055303
Date Filed 03/20/1991
State FL
Status **ACTIVE**

Principal Address

3805 FAYE ROAD
JACKSONVILLE, FL 32226

Changed: 10/03/2005

Mailing Address

3805 FAYE ROAD
JACKSONVILLE, FL 32226

Changed: 03/14/2011

Registered Agent Name & Address

NEMETH, ANNMARIE, CFO
3805 FAYE ROAD
JACKSONVILLE, FL 32226

Name Changed: 02/19/2018

Address Changed: 01/19/2006

Officer/Director Detail

Name & Address

Title D

WOOD, MARK S.
3805 FAYE ROAD
JACKSONVILLE, FL 32226

Title S, CFO

NEMETH, ANNMARIE
3805 FAYE ROAD
JACKSONVILLE, FL 32226

Title D, CEO

OGNJENOVIC, ZARKO
3805 FAYE ROAD
JACKSONVILLE, FL 32226

Title D, COO

BOZEMAN, ALBERT
3805 FAYE ROAD
JACKSONVILLE, FL 32226

Annual Reports

Report Year	Filed Date
2020	01/14/2020
2021	02/08/2021
2022	01/25/2022

Document Images

01/25/2022 -- ANNUAL REPORT	View image in PDF format
02/08/2021 -- ANNUAL REPORT	View image in PDF format
01/14/2020 -- ANNUAL REPORT	View image in PDF format
01/22/2019 -- ANNUAL REPORT	View image in PDF format
02/19/2018 -- ANNUAL REPORT	View image in PDF format
03/16/2017 -- ANNUAL REPORT	View image in PDF format
03/07/2016 -- ANNUAL REPORT	View image in PDF format
02/09/2015 -- ANNUAL REPORT	View image in PDF format
02/25/2014 -- ANNUAL REPORT	View image in PDF format
02/27/2013 -- ANNUAL REPORT	View image in PDF format
02/13/2012 -- ANNUAL REPORT	View image in PDF format
08/23/2011 -- ANNUAL REPORT	View image in PDF format
03/14/2011 -- ANNUAL REPORT	View image in PDF format
03/22/2010 -- ANNUAL REPORT	View image in PDF format
01/21/2009 -- ANNUAL REPORT	View image in PDF format
02/12/2008 -- ANNUAL REPORT	View image in PDF format
01/10/2007 -- ANNUAL REPORT	View image in PDF format
08/24/2006 -- ANNUAL REPORT	View image in PDF format
01/19/2006 -- ANNUAL REPORT	View image in PDF format
01/12/2005 -- ANNUAL REPORT	View image in PDF format
01/08/2004 -- ANNUAL REPORT	View image in PDF format
01/23/2003 -- ANNUAL REPORT	View image in PDF format
03/24/2002 -- ANNUAL REPORT	View image in PDF format

05/15/2001 -- ANNUAL REPORT	View image in PDF format
03/02/2000 -- ANNUAL REPORT	View image in PDF format
03/24/1999 -- ANNUAL REPORT	View image in PDF format
03/05/1998 -- ANNUAL REPORT	View image in PDF format
04/22/1997 -- ANNUAL REPORT	View image in PDF format
05/01/1996 -- ANNUAL REPORT	View image in PDF format
04/03/1995 -- ANNUAL REPORT	View image in PDF format

Florida Department of State, Division of Corporations

Inspections	\$ 1,333,280.00	\$ 673,489.00	\$ 404,758.50	\$ 256,908.50
Materials	\$ 458,375.00	\$ 530,785.00	\$ 299,900.00	\$ 114,870.46
	\$ 1,791,655.00	\$ 1,204,274.00	\$ 704,658.50	\$ 371,778.96

Inspection	Agent	Type	Unit Cost	Freq	Unit Total	Est. # Units	Cintas Total	Unit Cost	Total Price	Fire & Life Safety America	Unit Cost	Total Price	MJ Wood	Unit Cost	Total Price	Incumbent 8/2017 - Fixed 3 years, CPI, 4 and 5	INCREASE BY SERVICE	INCREASE BY %
m Inspection	Stored Pressure	Monthly	\$ 10.00	55	\$ 550.00	603	\$ 331,650.00	\$ 5.00	\$ 165,825.00	\$ 3.50	\$ 116,077.50	\$ 2.50	\$ 82,912.50	\$ 33,165.00	40%			
	Stored Pressure	Annual	\$ 25.00	5	\$ 125.00	603	\$ 75,375.00	\$ 8.00	\$ 24,120.00	\$ 6.50	\$ 19,597.50	\$ 4.00	\$ 12,060.00	\$ 7,537.50	63%			
Inspection - All other Sites	Stored Pressure	6-Year	\$ 35.00	1	\$ 35.00	603	\$ 21,105.00	\$ 50.00	\$ 30,150.00	\$ 15.00	\$ 9,045.00	\$ 11.00	\$ 6,633.00	\$ 2,412.00	36%			
	Cartridge Operated	Monthly	\$ 10.00	55	\$ 550.00	17	\$ 9,350.00	\$ 5.00	\$ 4,675.00	\$ 3.50	\$ 3,272.50	\$ 2.50	\$ 2,337.50	\$ 935.00	40%			
Inspection Fleet Service Center	Cartridge Operated	Annual	\$ 25.00	5	\$ 125.00	17	\$ 2,125.00	\$ 8.00	\$ 680.00	\$ 6.50	\$ 552.50	\$ 9.00	\$ 765.00	\$ (212.50)	-28%			
	Cartridge Operated	6-Year	\$ 35.00	1	\$ 35.00	17	\$ 595.00	\$ 50.00	\$ 850.00	\$ 15.00	\$ 255.00	\$ 8.50	\$ 144.50	\$ 110.50	76%			
	CO2	Monthly	\$ 10.00	55	\$ 550.00	140	\$ 77,000.00	\$ 5.00	\$ 38,500.00	\$ 3.50	\$ 26,950.00	\$ 2.50	\$ 19,250.00	\$ 7,700.00	40%			
	CO2	Annual	\$ 30.00	5	\$ 150.00	140	\$ 21,000.00	\$ 8.00	\$ 5,600.00	\$ 6.50	\$ 4,550.00	\$ 4.00	\$ 2,800.00	\$ 1,750.00	63%			
	CO2	6-Year	\$ 40.00	1	\$ 40.00	140	\$ 5,600.00	\$ 50.00	\$ 7,000.00	\$ 25.00	\$ 3,500.00	\$ 10.00	\$ 1,400.00	\$ 2,100.00	150%			
	Wheeled Unit	Monthly	\$ 50.00	55	\$ 2,750.00	22	\$ 60,500.00	\$ 5.00	\$ 6,050.00	\$ 3.50	\$ 4,235.00	\$ 3.00	\$ 3,630.00	\$ 605.00	17%			
	Wheeled Unit	Annual	\$ 125.00	5	\$ 625.00	22	\$ 13,750.00	\$ 15.00	\$ 1,650.00	\$ 10.50	\$ 1,155.00	\$ 25.00	\$ 2,750.00	\$ (1,595.00)	-58%			
	Wheeled Unit	6-Year	\$ 700.00	1	\$ 700.00	22	\$ 15,400.00	\$ 275.00	\$ 6,050.00	\$ 300.00	\$ 6,600.00	\$ 200.00	\$ 4,400.00	\$ 2,200.00	50%			
	Wheeled Unit w/Nitrogen	Monthly	\$ 50.00	55	\$ 2,750.00	3	\$ 8,250.00	\$ 5.00	\$ 825.00	\$ 3.50	\$ 577.50	\$ 3.00	\$ 495.00	\$ 82.50	17%			
	Wheeled Unit w/Nitrogen	Annual	\$ 225.00	5	\$ 1,125.00	3	\$ 3,375.00	\$ 15.00	\$ 225.00	\$ 65.00	\$ 975.00	\$ 25.00	\$ 375.00	\$ 600.00	160%			
	Wheeled Unit w/Nitrogen	6-Year	\$ 850.00	1	\$ 850.00	3	\$ 2,550.00	\$ 275.00	\$ 825.00	\$ 375.00	\$ 1,125.00	\$ 200.00	\$ 600.00	\$ 525.00	88%			
	Stored Pressure	Annual	\$ 25.00	5	\$ 125.00	1346	\$ 168,250.00	\$ 8.00	\$ 53,840.00	\$ 6.50	\$ 43,745.00	\$ 4.00	\$ 26,920.00	\$ 16,825.00	63%			
	Stored Pressure	6-Year	\$ 35.00	1	\$ 35.00	1346	\$ 47,110.00	\$ 50.00	\$ 67,300.00	\$ 15.00	\$ 20,190.00	\$ 11.00	\$ 14,806.00	\$ 5,384.00	36%			
	Cartridge Operated	Annual	\$ 40.00	5	\$ 200.00	19	\$ 3,800.00	\$ 35.00	\$ 3,325.00	\$ 12.00	\$ 1,140.00	\$ 9.00	\$ 855.00	\$ 285.00	33%			
	Cartridge Operated	6-Year	\$ 85.00	1	\$ 85.00	19	\$ 1,615.00	\$ 1.00	\$ 19.00	\$ 95.00	\$ 1,805.00	\$ 85.00	\$ 1,615.00	\$ 190.00	12%			
	CO2	Annual	\$ 30.00	5	\$ 150.00	352	\$ 52,800.00	\$ 8.00	\$ 14,080.00	\$ 6.50	\$ 11,440.00	\$ 4.00	\$ 7,040.00	\$ 4,400.00	63%			
	CO2	6-Year	\$ 40.00	1	\$ 40.00	352	\$ 14,080.00	\$ 50.00	\$ 17,600.00	\$ 25.00	\$ 8,800.00	\$ 10.00	\$ 3,520.00	\$ 5,280.00	150%			
	Wheeled Unit	Annual	\$ 125.00	5	\$ 625.00	4	\$ 2,500.00	\$ 15.00	\$ 300.00	\$ 10.50	\$ 210.00	\$ 25.00	\$ 500.00	\$ (290.00)	-58%			
	Wheeled Unit	6-Year	\$ 700.00	1	\$ 700.00	4	\$ 2,800.00	\$ 275.00	\$ 1,100.00	\$ 300.00	\$ 1,200.00	\$ 200.00	\$ 800.00	\$ 400.00	50%			
	Kitchen Suppression Sys	Semi-Annual	\$ 285.00	10	\$ 2,850.00	2	\$ 5,700.00	\$ 225.00	\$ 4,500.00	\$ 175.00	\$ 3,500.00	\$ 150.00	\$ 3,000.00	\$ 500.00	17%			
	Kitchen Suppression Sys	Hydrostatic	\$ 1,000.00	1	\$ 1,000.00	3	\$ 3,000.00	\$ 800.00	\$ 2,400.00	\$ 87.00	\$ 261.00	\$ 300.00	\$ 900.00	\$ (639.00)	-71%			
Stored Pressure	Annual	\$ 25.00	5	\$ 125.00	2400	\$ 300,000.00	\$ 8.00	\$ 96,000.00	\$ 6.50	\$ 78,000.00	\$ 2.50	\$ 30,000.00	\$ 48,000.00	160%				
Stored Pressure	6-Year	\$ 35.00	1	\$ 35.00	2400	\$ 84,000.00	\$ 50.00	\$ 120,000.00	\$ 15.00	\$ 36,000.00	\$ 11.00	\$ 26,400.00	\$ 9,600.00	36%				

Materials and Recharges
Fire Extinguisher Materials

Type	Unit Cost	Est. # Units
5# ABC Extinguisher	\$ 105.00	50
10# ABC Extinguisher	\$ 185.00	25
20# ABC Extinguisher	\$ 275.00	15
5# Purple K Extinguisher	\$ 145.00	500
20# Purple K Extinguisher	\$ 315.00	15
10# CO2 Extinguisher	\$ 500.00	15
20# CO2 Extinguisher	\$ 775.00	50
6L K-Class	\$ 500.00	1
2.5 Gal H2O/Water Mist	\$ 525.00	5
15.5# FE36	\$ 1,000.00	100
2.5 Gal AR-AFFF	\$ 100.00	10
150# Purple K Wheeled Unit	\$ 4,200.00	5
Labor & Signage	\$ 12.75	100

Fire Extinguisher Recharge from Discharge

Type	Unit Cost	st. # Units
5lb Dry Chemical	\$ 70.00	250
10lb Dry Chemical	\$ 90.00	50
20lb Dry Chemical	\$ 160.00	50
5lb Purple K	\$ 80.00	250
10lb Purple K	\$ 105.00	25
20lb Purple K	\$ 170.00	50
20lb Purple K (Cartridge Operated)	\$ 295.00	250
150lb Purple K (Wheeled Units)	\$ 650.00	5
5 lb CO2	\$ 110.00	5
10 lb CO2	\$ 155.00	5
15 lb CO2	\$ 190.00	5
20 lb CO2	\$ 210.00	25
2.5 gal AFFF	\$ 10.00	25
2.5 gal AR-AFFF	\$ 10.00	25
2.5 gal Water Mist	\$ 150.00	25
6 liter K-Class Wet Chemical	\$ 300.00	2
FE36 per pound	\$ 72.00	250

Other Materials

Type	Base Amount	M/U
Other Material Markup Percentage	\$ 20,000.00	30%

Totals	Unit Cost	Totals	Unit Cost	Totals	Unit Cost	Totals	Unit Cost	Totals	Unit Cost
\$ 5,250.00	\$ 65.00	\$ 3,250.00	\$ 65.00	\$ 3,250.00	\$ 26.85	\$ 1,342.50	\$ 1,907.50	142%	
\$ 4,625.00	\$ 105.00	\$ 2,625.00	\$ 98.00	\$ 2,450.00	\$ 40.83	\$ 1,020.75	\$ 1,429.25	140%	
\$ 4,125.00	\$ 225.00	\$ 3,375.00	\$ 165.00	\$ 2,475.00	\$ 76.30	\$ 1,144.50	\$ 1,330.50	116%	
\$ 72,500.00	\$ 75.00	\$ 37,500.00	\$ 75.00	\$ 37,500.00	\$ 36.63	\$ 18,315.00	\$ 19,185.00	105%	
\$ 4,725.00	\$ 245.00	\$ 3,675.00	\$ 215.00	\$ 3,225.00	\$ 36.63	\$ 549.45	\$ 2,675.55	487%	
\$ 7,500.00	\$ 225.00	\$ 3,375.00	\$ 275.00	\$ 4,125.00	\$ 111.26	\$ 1,668.90	\$ 2,456.10	147%	
\$ 38,750.00	\$ 350.00	\$ 17,500.00	\$ 389.00	\$ 19,450.00	\$ 150.94	\$ 7,547.00	\$ 11,903.00	158%	
\$ 500.00	\$ 225.00	\$ 225.00	\$ 215.00	\$ 215.00	\$ 115.81	\$ 115.81	\$ 99.19	86%	
\$ 2,625.00	\$ 225.00	\$ 1,125.00	\$ 239.00	\$ 1,195.00	\$ 108.60	\$ 543.00	\$ 652.00	120%	
\$ 100,000.00	\$ 850.00	\$ 85,000.00	\$ 1,287.00	\$ 128,700.00	\$ 318.55	\$ 31,855.00	\$ 96,845.00	304%	
\$ 1,000.00	\$ 1.00	\$ 10.00	\$ 100.00	\$ 1,000.00	\$ 101.23	\$ 1,012.30	\$ (12.30)	-1%	
\$ 21,000.00	\$ 38,000.00	\$ 190,000.00	\$ 3,495.00	\$ 17,475.00	\$ 1,937.18	\$ 9,685.90	\$ 7,789.10	80%	
\$ 1,275.00	\$ 15.00	\$ 1,500.00	\$ 65.00	\$ 6,500.00	\$ 58.00	\$ 5,800.00	\$ 700.00	12%	
Totals	Unit Cost	Total Price	Unit Cost	Total Price	Unit Cost	Total Price	Unit Cost	Total Price	
\$ 17,500.00	\$ 50.00	\$ 12,500.00	\$ 15.00	\$ 3,750.00	\$ 9.00	\$ 2,250.00	\$ 1,500.00	\$ 67%	
\$ 4,500.00	\$ 60.00	\$ 3,000.00	\$ 20.00	\$ 1,000.00	\$ 9.00	\$ 450.00	\$ 550.00	122%	
\$ 8,000.00	\$ 75.00	\$ 3,750.00	\$ 30.00	\$ 1,500.00	\$ 10.00	\$ 500.00	\$ 1,000.00	200%	
\$ 20,000.00	\$ 50.00	\$ 12,500.00	\$ 15.00	\$ 3,750.00	\$ 12.00	\$ 3,000.00	\$ 750.00	25%	
\$ 2,625.00	\$ 60.00	\$ 1,500.00	\$ 20.00	\$ 500.00	\$ 12.00	\$ 300.00	\$ 200.00	67%	
\$ 8,500.00	\$ 75.00	\$ 3,750.00	\$ 30.00	\$ 1,500.00	\$ 12.00	\$ 600.00	\$ 900.00	150%	
\$ 73,750.00	\$ 350.00	\$ 87,500.00	\$ 75.00	\$ 18,750.00	\$ 68.00	\$ 17,000.00	\$ 1,750.00	10%	
\$ 3,250.00	\$ 1,200.00	\$ 6,000.00	\$ 300.00	\$ 1,500.00	\$ 230.00	\$ 1,150.00	\$ 350.00	30%	
\$ 550.00	\$ 60.00	\$ 300.00	\$ 25.00	\$ 125.00	\$ 13.00	\$ 65.00	\$ 60.00	92%	
\$ 775.00	\$ 70.00	\$ 350.00	\$ 35.00	\$ 175.00	\$ 13.00	\$ 65.00	\$ 110.00	169%	
\$ 950.00	\$ 80.00	\$ 400.00	\$ 45.00	\$ 225.00	\$ 13.00	\$ 65.00	\$ 160.00	246%	
\$ 5,250.00	\$ 100.00	\$ 2,500.00	\$ 65.00	\$ 1,625.00	\$ 13.00	\$ 325.00	\$ 1,300.00	400%	
\$ 250.00	\$ 10.00	\$ 250.00	\$ 10.00	\$ 250.00	\$ 28.00	\$ 700.00	\$ (450.00)	-64%	
\$ 250.00	\$ 10.00	\$ 250.00	\$ 10.00	\$ 250.00	\$ 28.00	\$ 700.00	\$ (450.00)	-64%	
\$ 3,750.00	\$ 225.00	\$ 5,625.00	\$ 30.00	\$ 750.00	\$ 28.00	\$ 700.00	\$ 50.00	7%	
\$ 600.00	\$ 225.00	\$ 450.00	\$ 95.00	\$ 190.00	\$ 75.00	\$ 150.00	\$ 40.00	27%	
\$ 18,000.00	\$ 60.00	\$ 15,000.00	\$ 50.00	\$ 12,500.00	\$ 25.00	\$ 6,250.00	\$ 6,250.00	100%	

Total	M/U	Total	M/U	Total	M/U
\$ 26,000.00	30%	\$ 26,000.00	20%	\$ 24,000.00	15%

\$ 458,375.00 \$ 530,785.00 \$ 299,900.00 \$ 114,870.46

Fire Extinguisher Services Budget

Cost Center	Exp. Type	FY23	FY24	FY25	FY26	FY27	Award Amount
31000	BL08 - 2006	\$ 90,000.00	\$ 153,664.63	\$ 153,664.63	\$ 153,664.63	\$ 153,664.63	\$ 704,658.50



Formal Bid and Award System

Award #5 August 25, 2022

Type of Award Request: REQUEST PROPOSAL (RFP)
Requestor Name: Horn, Derek – Associate Engineer
Project Title: Engineering Services – Protection and Controls
Project Number: 8007275
Project Location: JEA
Funds: Capital
Budget Estimate: \$750,000.00 (Award to Budget)

Scope of Work:

This Solicitation is for JEA to obtain General Engineering Services of an experienced engineering firm with technical expertise in engineering generator and transmission Protection and Control (P&C) projects to supplement JEA's internal design staff (The "Work"). The Work will consist of performing engineering and design services as requested by JEA in support of engineering Generator and Transmission Protection and Control (P&C) projects for which the estimated construction cost as set forth in Florida Statutes Section 287.055, known as the Consultants' Competitive Negotiation Act (CCNA).

JEA will award up to three (3) contracts to the three (3) most highly qualified firms that meet the minimum qualifications to submit a proposal and with which JEA is able to successfully negotiate a contract. JEA anticipates needing up to three (3) contracts to meet its future demand for this type of work because JEA may not have the manpower or expertise to handle internally.

The proposing engineering firm will need to allow its engineers to work on-site with JEA engineers, and also be able to work from their corporate office. The firm's staff should be proficient with relays manufactured by Schweitzer Engineering Laboratories (SEL) and the following computer programs: Microstation, Aspen OneLiner, Aspen Distriview, and SEL applications (AcSELeRator Quickset/Diagram Builder/RTAC, SEL Settings Assistant, SEL-5010, etc.). All design work shall be in compliance with JEA standards as deemed acceptable by the JEA project engineer and located at the following link:

https://www.jea.com/Engineering_and_Construction/Electric_Reference_Materials/

All design work shall be in compliance with all applicable codes and industry standards including, but not limited to, NEC, NESC, IEEE/ANSI.

JEA IFB/RFP/State/City/GSA#: 1410636046
Purchasing Agent: Lovgren, Rodney
Is this a Ratification?: NO

RECOMMENDED AWARDEE(S):

Name	Contact Name	Email	Address	Phone	Amount
LEIDOS ENGINEERING, LLC	Robert Jennings	Robert.L.Jennings@leidos.com	12901 Science Drive, Orlando FL, 32828	(813) 777-8198	\$600,000.00

POWER ENGINEERS INC.	Ivette Sanchez	Ivette.sanchez@powereng.com	3940 Glenbrook Drive, Hailey, Idaho 83333	(208) 788-3456	\$75,000.00
BLACK & VEATCH	Thomas Lind	lindtr@bv.com	201 South Orange Avenue, Suite 500, Orlando, FL 32801	(407) 419-8015	\$75,000.00

Amount for entire term of Contract/PO: \$750,000.00
Award Amount for remainder of this FY: \$0.00
Length of Contract/PO Term: Three (3) Years, Two – 1 Yr, Renewals
Begin Date (mm/dd/yyyy): 10/01/2022
End Date (mm/dd/yyyy): 09/30/2025
Renewal Options: Yes - Two – 1 Yr. Renewals
JSEB Requirement: Optional

Comments on JSEB Requirements:

Leidos Engineering, LLC – Listed No JSEB
Power Engineers INC – Listed No JSEB
Black & Veatch – Listed No JSEB

PROPOSERS:

Name	Score	Rank
LEIDOS ENGINEERING, LLC	80.5	1
POWER ENGINEERS, INC	78.2	2
BLACK & VEATCH	75.3	3
BURNS & MCDONNELL	71.6	4
SUBGRID SOLUTIONS LLC	73.1	4
CHEN MOORE & ASSOCIATES	62.0	6
POWER GRID ENGINEER LLC	58.9	7

Background/Recommendations:

Advertised on 03/16/2022. Nine (9) prime companies attended the optional pre-proposal meeting held on 03/29/2022. At proposal opening on 04/19/2022, JEA received seven (7) Proposals. The public evaluation meeting was held on 07/12/2022 and JEA deemed Leidos Engineering LLC, Power Engineers Inc. and Black & Veatch, as the three (3) most qualified to perform the work. A copy of the evaluation matrix and negotiated schedule and fees are attached as backup.

For continuing services contracts, JEA does not have a set forecast of when each engineering project will be released and total project amount be to awarded to engineering firms beyond the current and next approved fiscal year. As such, JEA will preliminarily fund the contract and will return to awards committee to add funds to the contracts to fund work as projects are released and scope of work are determined.

The engineering services group will issue task orders as required to facilitate the work. The work may be awarded based on contracted rates (i.e. lowest rates for scope) or based on specialty (some firms have more experience in specific types of work).

The proposed engineering rates are compared on an aggregate average basis per firm. When comparing the aggregate average rates index of \$134.55 to the bid index \$144.16, the bid rate average is 7.1% higher and are deemed reasonable. The rates are subject to CPI price adjustment annually with a cap of six percent (6%).

1410636046 – Request approval to award contracts to Leidos Engineering LLC \$600,000.00, Power Engineers Inc. \$75,000.00 and Black & Veatch \$75,000.00 for protection and controls engineering services for a total amount of \$750,000.00, subject to the availability of lawfully appropriated funds.

Manager: Heaton, Ryan C. - Mgr System Protection and Control Projects
Director: Acs, Gabor - Sr Dir Engineering & Projects
VP: Erixton, Ricky D. - VP Electric Systems

APPROVALS:

<u>Stephen Datz</u>	8/25/2022
Chairman, Awards Committee	Date
<u>Stephanus M Nealy</u>	8/25/2022
Budget Representative	Date

1410636046 Protection & Controls Engineering Services Summary Evaluation Matrix								
#	Vendor Rankings	Heaton	Rao	Hamilton	Horn	Σ Rank	Rank	Total Score
1	Black & Veatch	5	3	2	3	13	3	301.00
2	Burns & McDonnell	3	5	5	2	15	4	286.50
3	Chen Moore & Associates	6	7	6	6	25	6	248.00
4	Leidos Engineering LLC	1	1	3	1	6	1	322.00
5	Power Engineerings INC	4	1	1	4	10	2	312.75
6	Power Grid Engineer LLC	7	6	7	7	27	7	235.75
7	Subgrid Solutions LLC	2	4	4	5	15	4	292.50
8		8	8	8	8	32	8	0.00
9		8	8	8	8	32	8	0.00
10		8	8	8	8	32	8	0.00
#	Heaton	Professional Staff Experience (20 Points)	Company Experience (75 Points)	JSEB (5 Points)			Total	Rank
1	Black & Veatch	12.8	38.0	0.0			50.75	5
2	Burns & McDonnell	13.8	36.0	4.0			53.75	3
3	Chen Moore & Associates	11.5	30.0	4.0			45.50	6
4	Leidos Engineering LLC	15.3	42.0	0.0			57.25	1
5	Power Engineerings INC	13.3	40.0	0.0			53.25	4
6	Power Grid Engineer LLC	8.5	36.0	0.0			44.50	7
7	Subgrid Solutions LLC	14.5	38.0	4.0			56.50	2
8	0						0.00	8
9	0						0.00	8
10	0						0.00	8
	Rao	Professional Staff Experience (20 Points)	Company Experience (75 Points)	JSEB (5 Points)			Total	Rank
1	Black & Veatch	20.0	64.0	0.0			84.00	3
2	Burns & McDonnell	20.0	57.0	4.0			81.00	5
3	Chen Moore & Associates	15.0	46.0	4.0			65.00	7
4	Leidos Engineering LLC	17.5	75.0	0.0			92.50	1
5	Power Engineerings INC	17.5	75.0	0.0			92.50	1
6	Power Grid Engineer LLC	12.5	64.0	0.0			76.50	6
7	Subgrid Solutions LLC	15.0	64.0	4.0			83.00	4
8	0						0.00	8
9	0						0.00	8
10	0						0.00	8

POWER ENGINEERS INC.
SCHEDULE OF CHARGES – 2022
JEA

This standard Schedule of Charges is for professional services. Unless agreed otherwise, charges for work on continuing projects will be based on the then current Schedule of Charges. Invoices will be submitted monthly and/or upon completion of the work and will be due and payable when issued. All accounts not paid within thirty (30) days after Owner's receipt of the invoice will bear a **SERVICE CHARGE OF 1.0% PER MONTH** for each month the invoice is unpaid.

<u>GRADE</u>	<u>PERSONNEL CLASSIFICATION</u>	
13	President Executive Vice President Senior Project Manager IV	\$216.00/hr.
12	Project Manager Director Senior Project Manager III	\$216.00/hr.
11	Senior Project Manager II..... Senior Program Manager II Principle Engineer II	\$216.00/hr.
10	Senior Project Manager I..... Senior Program Manager I Senior Project Engineer III Senior Project Lead III Strategic Consultant III Principle Engineer I	\$216.00/hr.
9	Project Manager III Senior Project Lead II Construction Manager III Senior Project Engineer II Strategic Consultant II Senior Consultant III Senior Engineer II	\$216.00/hr.
8	Project Manager II..... Senior Project Lead I Strategic Consultant I Senior Consultant II Senior Project Engineer I Construction Manager II Senior Engineer I	\$194.00/hr.
7	Project Manager I Project Lead II Construction Manager I Environmental Specialist IV Project Engineer II Engineer IV Designer V Project Administrator III Senior Consultant I	\$166.00/hr.
6	Project Lead I Project Engineer I Engineer III Designer IV Environmental Specialist III Procurement Specialist III Scheduling Specialist III Project Administrator II Consultant III	\$156.00/hr.
5	Engineer II Designer III Technician IV Environmental Specialist II Procurement Specialist II Scheduling Specialist II Project Administrator I Consultant II	\$145.00/hr.
4	Engineer I Designer II Technician III Environmental Specialist I Procurement Specialist I Field Representative IV Scheduling Specialist I Project Managers Assistant III Consultant I	\$132.00/hr.
3	Designer I Drafter III Technician II Field Representative III Staff Assistant II Project Managers Assistant II	\$118.00/hr.
2	Drafter II Staff Assistant Field Representative II Project Managers Assistant I	\$98.00/hr.
1	Drafter I General Office Assistant Field Representative I	\$78.00/hr.

Personnel with specialized experience are employed by or on retainer to POWER. Charges for these specialists are negotiated on an individual basis depending on the assignment. Professional time for depositions and testimony is charged at 1.5 times the rate for services; full-day minimums apply.

**POWER ENGINEERS INC.
SCHEDULE OF CHARGES – 2022
JEA**

This standard Schedule of Charges is for professional services. Unless agreed otherwise, charges for work on continuing projects will be based on the then current Schedule of Charges. Invoices will be submitted monthly and/or upon completion of the work and will be due and payable when issued. All accounts not paid within thirty (30) days after Owner's receipt of the invoice will bear a **SERVICE CHARGE OF 1.0% PER MONTH** for each month the invoice is unpaid.

REPRODUCTION**Drawings – Black & White**

Large Scale Drawings (C Size)	\$1.90/ea.
Large Scale Drawings (D Size)	\$3.30/ea.
Large Scale Drawings (E Size)	\$5.50/ea.

Drawings – Color

Large Scale Drawings (C Size)	\$6.00/ea.
Large Scale Drawings (D Size)	\$10.90/ea.
Large Scale Drawings (E Size)	\$17.50/ea.

Documents – Black & White

Single-sided Copies	8 x 11 \$0.11/ea.	11 x 17 \$0.17/ea.
Double-sided Copies	8 x 11 \$0.22/ea.	11 x 17 \$0.34/ea.

Documents – Color

Single-sided Copies	8 x 11 \$0.50/ea.	11 x 17 \$1.00/ea.
Double-sided Copies	8 x 11 \$1.00/ea.	
Spiral Comb		\$2.65/ea.
3 Ring Binder		Dependent on size
Special Copy Center Projects (Labor)		\$45.00/hr.

SURVEY EQUIPMENT

Survey Equip. to support field crew		\$70.00/day
GPS Equipment 2 Units	\$60.00/hour	\$350.00/day
GPS Equipment 3 Units	\$80.00/hour	\$450.00/day

Other expenses including but not limited to subcontractors, airfare, lodging, meals, postage and shipping, purchases, rentals, are charged at cost plus a carrying and handling charge of 10%.

Communication Charge - including but not limited to VOIP charges, file sharing cloud services, and web collaboration sites, charged at 1% of labor billing charges.

CAD and Software Usage Charge – charged at 3% of labor billing charges. This charge covers CAD application and design software including: AutoCAD, MicroStation, Autodesk Revit, PLS-Cad, Smart Plant P&ID, electrical studies software, and other design software as required.

Labor Rate Adjustment:

Effective January 1, 2022 and annually thereafter, Labor rates will be increased by 3.0% per year subject to the following criteria:

- a) Utilizing data from the ECI (Employment Cost Index) for Professional, Scientific, and Technical Services, develop an escalation control factor (ECF). The ECF will be the percentage change listed for the 12 months ending September of the current year. Data points to determine the ECF will be found at Table 5, www.bls.gov/news.release/eci.t05.htm; and shall be considered along with the prevailing Orlando economics conditions inclusive of salary increases by OUC.
- b) If the 3.0% annual labor increase is within $\pm 20\%$ of the ECF, Labor rates will increase by 3.0%;
- c) If the 3.0% annual labor increase is outside $\pm 20\%$ of the ECF, POWER and OUC will negotiate mutually acceptable labor rate adjustment;
- d) In no event shall the annual Labor rate adjustment exceed 5.0% per year nor shall it be less than 0.0% per year;
- e) All Labor rate adjustments will become effective on 1/1 and remain in effect until 12/31 of the calendar year;
- f) In the event that the BLS stops producing the ECI for Professional, Scientific, and Technical Services, POWER and OUC will negotiate a mutually acceptable BLS index to serve as the basis for the ECF.
- g) Notwithstanding, rate increases are subject to review and approval by the Annual Performance Review Committee.

Leidos Rate Sheets - 2022

Job Class	Hourly Rate
Senior Project Manager	\$ 191.00
Project Manager	\$ 169.00
E7 - Principal Engineer	\$ 213.00
E6 - Senior Engineer	\$ 190.00
E5 - Project Engineer II	\$ 175.00
E4 - Project Engineer I	\$ 160.00
E3 - Engineer III	\$ 145.00
E2 - Engineer II	\$ 120.00
E1 - Engineer I	\$ 100.00
D4 - Designer 4	\$ 144.00
D3 - Designer 3	\$ 126.00
D2 - Designer 2	\$ 107.00
D1 - Designer I	\$ 93.00
C3 - CADD draftsman III	\$ 91.00
C2 - CADD draftsman II	\$ 77.00
C1 - CADD draftsman 1	\$ 66.00
Associate Project Manager	\$ 144.00
Analyst	\$ 100.00
Administrative Assistant	\$ 71.00

July 27, 2022

JEA
21 West Church Street
Jacksonville, Florida 32202

Attention: Rodney Lovgren

Subject: Black & Veatch Proposed Billing Rates 2023-JEA RFP Solicitation 1410636046
Electrical Engineering Services for Automation, Protection and Controls General
Engineering Services

We are pleased to submit the attached proposed billing rates for the Engineering Services RFP referenced above.

We appreciate the opportunity to continue providing engineering services to JEA. If you have any questions or comments, please call T.R. Lind at 407.419.8015 or contact him at LindTR@BV.com.

Very truly yours,

Rene A.
Dominguez
Argueta

Digitally signed by Rene
A. Dominguez Argueta
Date: 2022.07.27
14:06:04 -04'00'

BLACK & VEATCH
Rene A. Dominguez Argueta
Project Director, AVP

Enclosure

Black & Veatch Power Delivery Engineering Rates

Owner shall pay Engineer for the performance of Services the sum of the following amounts.

- (1) Personnel hours applied to the Services at the hourly bill rates listed below.
- (2) An amount equal to the actual out-of-pocket cost for travel and subsistence in accordance with Engineer's travel policies, and for atypical expenses applied to the Services.
- (3) The actual cost paid by the Engineer to independent subcontractors plus a 7.5% markup.

Personnel Classification	Grade	2023 Rates
Administrative Support (ADO)	003	49.67
	004	68.15
	005	81.02
Engineering (ENG)	127	119.67
	128	125.38
	129	130.20
	130	159.78
	131	223.04
	132	231.00
	133	231.00
Engineering Specialist (ENS)	130	135.99
Engineering Technician (ENT)	126	89.93
	127	97.41
	128	118.77
	129	124.47
	130	143.29
Project Controls (PJC)	001	104.49
	002	119.26
	003	129.39
	004	149.66
Project Management (PMT)	007	229.55
	001	240.55
	003	249.99
Specialized Staff (SPC)	007	314.77
	002	106.78

Notes:

1. Rates list above are firm for the first 12 months of the MSA. Black & Veatch reserves the right to review and revise the rates in accordance with Section 2.38 of the MSA terms in an amount up to the Consumer Price Index (CPI) limits or a 4% maximum adjustment, whichever is less.
2. Personnel classifications and grades not listed above shall be added at equitable rates if applied to the Services.
3. The same billing rate shall apply to regular time and to overtime.
4. The billing rates include all payroll burdens, overheads, and profit.
5. The billing rates include routine office expenses including computers, reprographics, copying, and communications.
6. The Services shall include administrative activities directly related to the Project. Administrative activities not directly related to the Project shall not be invoiced.
7. Engineer's accounting year consists of 12 periods, with a total of 2,080 working hours.

July 27, 2022

JEA RFP Solicitation 1410636046 Electrical Engineering Services for Automation, Protection and Controls General Engineering Services

1410636046 - Pricing Evaluation Comparison

Liedos			Power Eng			Black and Veatch			
Job Title	2017-2022	2022-2025	Job Title	2017-2022	2022 - 2025	Job Title		2017-2022	2022-2025
Senior Project Management	\$ 190.96	\$ 191.00	Senior Project Engineer II (Grade 9)	\$ 203.00	\$ 216.00	Project Management (PMT)	7	\$ 278.00	\$ 314.77
Project Manager	\$ 164.44	\$ 169.00	PM III & Senior PM (Grade 9)	\$ 203.00	\$ 216.00	Project Management (PMT)	3	\$ 221.00	\$ 249.99
Associate Project Manager	\$ 143.22	\$ 144.00	Project Manager II (Grade 8)	\$ 181.00	\$ 216.00	Project Management (PMT)	1	\$ 212.69	\$ 240.55
Principal Engineer	\$ 206.88	\$ 213.00	Senior Project Engineer I (Grade 8)	\$ 181.00	\$ 216.00	Project Controls (PJC)	7	\$ 229.55	\$ 229.55
Senior Engineer	\$ 180.35	\$ 190.00	Project Engineer (Grade 7)	\$ 157.00	\$ 166.00	Project Controls (PJC)	6	\$ 194.76	\$ 194.76
Project Engineer 2	\$ 169.74	\$ 175.00	Project Lead (Grade 7)	\$ 157.00	\$ 166.00	Project Controls (PJC)	4	\$ 132.71	\$ 149.66
Project Engineer 1	\$ 148.53	\$ 160.00	Engineer III (Grade 6)	\$ 147.00	\$ 156.00	Project Controls (PJC)	3	\$ 114.88	\$ 129.39
Engineer 3	\$ 132.61	\$ 145.00	Engineer II (Grade 5)	\$ 135.00	\$ 145.00	Project Controls (PJC)	2	\$ 105.96	\$ 119.26
Engineer 2	\$ 114.58	\$ 120.00	Engineer I (Grade 4)	\$ 125.00	\$ 132.00	Project Controls (PJC)	1	\$ 124.41	\$ 104.49
Engineer 1	\$ 95.48	\$ 100.00	Designer IV (Grade 6)	\$ 147.00	\$ 156.00	Engineering (ENG)	133	\$ 231.00	\$ 231.00
Designer 4	\$ 143.22	\$ 144.00	Designer III (Grade 5)	\$ 135.00	\$ 145.00	Engineering (ENG)	132	\$ 204.29	\$ 231.00
Designer 3	\$ 122.00	\$ 126.00	Designer II (Grade 4)	\$ 125.00	\$ 132.00	Engineering (ENG)	131	\$ 197.28	\$ 223.04
Designer 2	\$ 103.97	\$ 107.00	Designer I (Grade 3)	\$ 109.00	\$ 118.00	Engineering (ENG)	130	\$ 141.62	\$ 159.78
Designer 1	\$ 90.18	\$ 93.00	Drafter III (Grade 3)	\$ 109.00	\$ 118.00	Engineering (ENG)	129	\$ 115.59	\$ 130.20
Drafter/CAD 3	\$ 81.69	\$ 91.00	Drafter II (Grade 2)	\$ 93.00	\$ 98.00	Engineering (ENG)	128	\$ 111.35	\$ 125.38
Drafter/CAD 2	\$ 72.14	\$ 77.00	Drafter I (Grade 1)	\$ 73.00	\$ 78.00	Engineering (ENG)	127	\$ 106.32	\$ 119.67
Drafter/CAD 1	\$ 63.65	\$ 66.00	Staff Assistant II (Grade 2)	\$ 93.00	\$ 98.00	Engineering Specialist (ENS)	130	\$ 135.99	\$ 135.99
Administrative Assistant	\$ 68.96	\$ 68.96	Staff Assistant I (Grade 1)	\$ 73.00	\$ 78.00	Engineering Technician (ENT)	130	\$ 127.11	\$ 143.29
Analyst	\$ 100.00	\$ 100.00	Aggregate Averages	\$ 135.89	\$ 147.22	Engineering Technician (ENT)	129	\$ 110.55	\$ 124.47
Aggregate Averages	\$ 125.93	\$ 130.52	Agg. Aver. % Increase		8.3%	Engineering Technician (ENT)	128	\$ 105.53	\$ 118.77
Agg. Aver. % Increase		3.7%				Engineering Technician (ENT)	127	\$ 86.74	\$ 97.41
						Engineering Technician (ENT)	126	\$ 80.15	\$ 97.41
						Administrative Support (ADS)	4	\$ 72.31	\$ 81.02
						Administrative Support (ADS)	3	\$ 60.99	\$ 68.15
						Administrative Support (ADS)	2	\$ 44.73	\$ 49.67
						Aggregate Averages		\$ 141.82	\$ 154.75
						Agg. Aver. % Increase			9.1%

Agg. Averages	\$ 134.55	\$ 144.16
		7.1%

Company	Project	Expense Type	FY23	FY24	FY25	FY26	FY27	Totals
Leidos	8007275	2002	\$ 200,000.00	\$ 200,000.00	\$ 200,000.00			\$ 600,000.00
Leidos			\$ -	\$ -	\$ -	\$ -	\$ -	\$ -
Black & Veatch	8007275	2002	\$ 25,000.00	\$ 25,000.00	\$ 25,000.00	\$ -	\$ -	\$ 75,000.00
Black & Veatch			\$ -	\$ -	\$ -	\$ -	\$ -	\$ -
Power Engineers	8007275	2002	\$ 25,000.00	\$ 25,000.00	\$ 25,000.00	\$ -	\$ -	\$ 75,000.00
Power Engineers			\$ -	\$ -	\$ -	\$ -	\$ -	\$ -
Award Total								\$ 750,000.00



Formal Bid and Award System

Award #6 August 25, 2022

Type of Award Request: CONTRACT EXTENSION
Requestor Name: Becker, Carl R. - Manager Benefits Services
Requestor Phone: (904) 665-7985
Project Title: Gym Management Services
Project Number: A0205
Project Location: JEA
Funds: O&M
Budget Estimate: \$103,668.00

Scope of Work:

This request is for a contract extension of the Gym Management Services contract for JEA's employee benefit program. The company shall provide gym management services for JEA fitness facilities located at various JEA sites throughout our service territory. Staffing levels shall include a corporate Manager of Wellness and Fitness Facilities Operations employed by a Gym Management Company to oversee all JEA fitness facilities. In addition to this full-time supervisor position, the Gym Management Company shall provide group exercise instructors and personal trainers as determined by JEA. JEA has approximately two thousand (2000) employees who have the option to pay membership to belong to one (1) or more of the eight (8) JEA gym facilities.

JEA IFB/RFP/State/City/GSA#: 97400
Purchasing Agent: Selders, Elaine Lynn
Is this a ratification?: NO

RECOMMENDED AWARDEE(S):

Name	Contact Name	Email	Address	Amount
CORPORATE FITNESS WORKS, INC.	Emily Manley	emanley@teamcfw.com	1200 16 th Street North, St. Petersburg, FL 33705	\$106,776.00

Amount of Original Award: \$101,760.00
Date of Original Award: 07/11/2019
Renewal Amount: \$106,776.00

List of Previous Change Order/Amendments:

CPA #	Amount	Date
184134	\$103,668.00	09/03/2020
184134	\$94,572.00	09/15/2021

New Not-To-Exceed Amount: \$406,776.00

Length of Contract/PO Term: One (1) Year w/Two (2) – 1 Yr. Renewals
Begin Date (mm/dd/yyyy): 09/19/2019
End Date (mm/dd/yyyy): 09/18/2023
Renewal Options: None Remaining
JSEB Requirement: N/A - Optional

Background/Recommendations:

Competitively bid and awarded informally to Corporate Fitness Works, Inc. on 07/11/2019, in the amount of \$101,760.00. The original Response Form is attached as backup. The contract was renewed on 09/03/2020 in the amount of \$103,668.00, for a new not-to-exceed amount of \$205,428.00. This renewal included an agreed upon increase in the amount of \$1,908.00 for additional liability insurance coverage. The second renewal was completed 09/15/2021, in the amount of \$94,572.00, for a new not-to-exceed amount of \$300,000.00. The second renewal amount was lower due to funds remaining on the contract from the two previous years and allowed this contract to remain under the formal threshold.

This request is for an additional one-year contract extension from 09/19/2022 to 09/18/2023. It was determined to be in JEA’s best interest to extend this contract for one additional year to provide consistency and assist with the move to our new headquarters. Corporate Fitness Works, Inc. has been instrumental in soliciting and receiving discounts on new equipment purchases for the new gym and the preference was to avoid disruption during the move to the new site. The award amount of \$106,776.00 is based on the monthly fee of \$8,898.00 for the gym management service fee and gym managers salary and benefits. JEA approved a 3% increase in the contract amount for this final year of the contract based on the annual amount of \$103,668.00. The updated pricing has been attached as backup.

Request approval to award a one (1) year contract extension to Corporate Fitness Works, Inc. for the Gym Management Services in the amount of \$106,776.00, for a new not-to-exceed amount of \$406,776.00, subject to the availability of lawfully appropriated funds.

Manager: Becker, Carl R. - Manager Benefits Services
Director: Maillis, Patricia L. – Director, Employee Services
Chief: Emanuel, L. David - Chief Human Resources Officer

APPROVALS:

Stephen Datz 8/25/2022

Chairman, Awards Committee **Date**

Stephanie M Healy 8/25/2022

Budget Representative **Date**

**ADDENDUM 2 – BAFO - APPENDIX B – RESPONSE FORM
ITN 97400 - GYM MANAGEMENT SERVICES**

RESPONDENT INFORMATION:

COMPANY NAME: Corporate Fitness Works
BUSINESS ADDRESS: 1200 16th St. N.
CITY, STATE, ZIP CODE: St. Petersburg FL 33705
TELEPHONE: (727) 522-2900
FAX: _____
NAME & EMAIL OF CONTACT: Ken Viglio; kviglio@teamcfw.com; (954) 368-2026
WEBSITE: www.corporatefitnessworks.com

QUOTATION OF RATES

Maximum score for criterion is: **40 Points**

Respondent shall provide a firm-fixed lump sum price for the term of the project as specified in the Technical Specifications by completing the information on the Response Form located in Appendix B of this ITN. The lump sum price submitted by the Respondent **shall be all inclusive and shall include the annual salary for the Manager, Wellness and Fitness Facilities Operation and Management Service Fee.**

Transfer total from Appendix B – Response Workbook.

	Total BAFO Response Price
	\$ <u>101,760</u>

Please note, the prices quoted by Respondent on the Response Form must be firm-fixed prices, not estimates.

I have read and understood the Sunshine Law/Public Records clauses contained within this solicitation. I understand that in the absence of a redacted copy my proposal will be disclosed to the public “as-is”.

Respondent's Certification

By submitting this Response, the Respondent certifies (1) that it has read and reviewed all of the documents pertaining to this ITN and agrees to abide by the terms and conditions set forth therein, (2) that the person signing below is an authorized representative of the Respondent, and (3) that the Respondent is legally authorized to do business and maintains an active status in the State of Florida. The Respondent certifies that its recent, current, and projected workload will not interfere with the Respondent’s ability to work in a professional, diligent and timely manner.

The Respondent certifies, under penalty of perjury, that it holds all licenses, permits, certifications, insurances, bonds, and other credentials required by law, contract or practice to perform the Work. The Respondent also certifies that, upon the prospect of any change in the status of applicable licenses, permits, certifications, insurances, bonds or other credentials, the Respondent shall immediately notify JEA of status change.

We have received addenda 1 through 1 _____

DocuSigned by:
Christine Hart
81A7DB88FF7347D...
Signature of Authorized Officer of Respondent or Agent

7/1/2019
Date

Christine Hart – Vice President of Finance
Printed Name & Title

727-300-0729
Phone Number

Corporate Fitness Works is pleased to present the following pricing proposal to JEA for an amended Contract 97400 -Gym Management Services for September 20, 2022, through September 30, 2023:

Annual Gym Management Service Fee	\$22,980.00
Annual Manager, Wellness and Fitness Facilities Operations Salary and Benefits	\$83,796.00
Total	\$106,776.00

Pricing increase:

- Includes 3% salary increase for Health Fitness Program Manager and fees related to the Team Leader.

SOW addition to reflect current operations:

- Includes Fitness Center supervision and Team Leader services from part time Team Leaders at JEA Wellness Centers.
- Additional, mutually agreed upon, staffing hours are included in the monthly invoice as a pass-through expense and only actuals are billed at the loaded rate of \$25 per hour.



Formal Bid and Award System

Award #7 August 25, 2022

Type of Award Request: RESCIND
Requestor Name: Chmist, Sebastian M.
Requestor Phone: (904) 665-7016
Project Title: Design-Build services for 138kv / 230kv Fulton Cut Replacement
Project Number: N/A
Project Location: JEA
Funds: Capital
Budget Estimate: N/A

Scope of Work:

The purpose of this Request for Proposals (this "RFP") is to evaluate and select a Company that can provide Design-Build Services for the 138 and 230 kV Fulton Cut transmission tower replacement (collectively, the "Work" or "Services").

The Company to be Awarded will be comprised of a Contractor and an Engineering firm to perform all engineering, design and construction services needed to replace transmission lattice towers and increase clearances of six (6) existing overhead 138kV and 230kV transmission circuits 840, 918, 926, 934, 935, and 938 across the Fulton Cut near Jax Port in Jacksonville, Florida. Figure 1 below illustrates the project location.

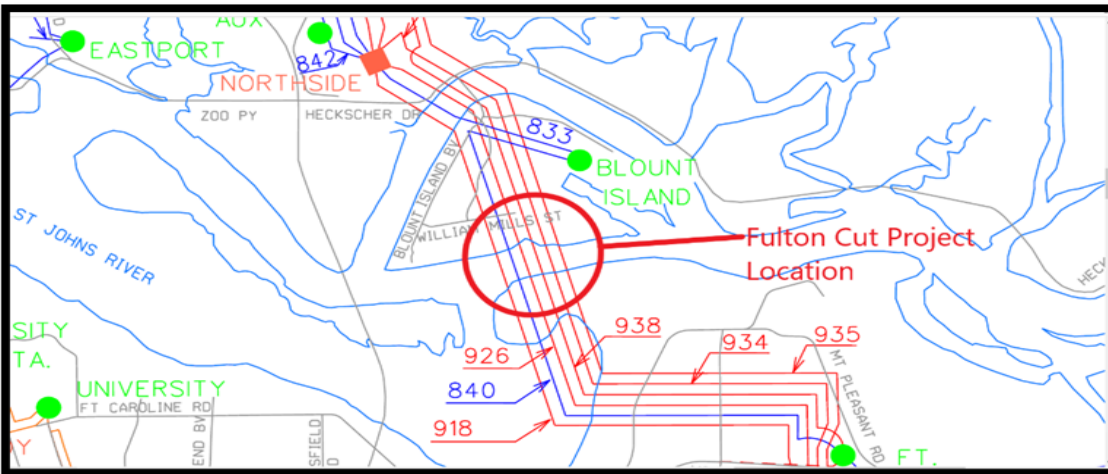

Figure 1: Existing Transmission System Map Project Location

The scope of work for this project includes engineering and contractor services which will be competitively sourced as a single team through this solicitation process. The selected team will create a 10% drawing (plan), to be approved by all stakeholders.

The 30%, 60%, 90% and 100% design documents will then be created, with stakeholder review at each phase. The required construction documents will be subject to review and approval by the JEA Engineering team.

Long lead Items: JEA may purchase long lead and expensive capital items to reduce the construction timeline, where such purchase is beneficial to JEA.

JEA IFB/RFP/State/City/GSA#: 1410755046
Purchasing Agent: Lovgren, Rodney

Is this a Ratification?: NO
JSEB Requirement: N/A

BIDDERS:

Vendor Name	Score
MICHELS POWER, INC.	N/A
QUANTA INFRASTRUCTURE SOLUTIONS GROUP, LLC	N/A

Background/Recommendations:

Advertised on 06/09/2022. A mandatory site visit and pre-bid were held on 06/21/2021, twenty-three (23) companies attended, twelve (12) of which were prime contractors. Up through the week of Bid opening, JEA was receiving inquiries from four (4) companies. At Bid Opening JEA received two (2) Bids.

JEA began to review minimum qualifications and noted one (1) company did not meet the minimum qualifications. JEA received feedback from several companies that the complexity of the project, the time of year, current workloads, difficulty in putting together the team and minimum qualifications as reasons they did not elect to bid. JEA intends to rebid the scope of work with revised qualification requirements to help improve competition. Bids will remain sealed for one (1) year, or until the replacement solicitation is processed and awarded.

Request approval to rescind the Bid for Design-Build services for 138kv / 230kv Fulton Cut Replacement Project and reject all responses to rebid with revised minimum qualifications.

Manager: Hamilton, Darrell D., Mgr Transmission & Substation Projects
Sr. Director: Acs, Gabor, Sr. Dir. Engineering & Projects
VP: Erixton, Ricky D., VP - Electric Systems

APPROVALS:

Stephen Datz 8/25/2022

Chairman, Awards Committee

Date



Formal Bid and Award System

Award #9 August 25, 2022

Type of Award Request: PIGGYBACK – CITY OF JACKSONVILLE (COJ)
Requestor Name: Hightower, Justin
Requestor Phone: (904) 665-8357
Project Title: Joint Agency Fuel Supply Products, Fuel Cards, and Related Services
Project Location: JEA
Funds: O&M
Budget Estimate: \$19,616,421.15

Scope of Work:

The purpose of the City of Jacksonville's Invitation to Bid SC-0411-22 was to evaluate and select a vendor that can provide fuel supply products, retail fuel cards, and fuel related services at the best value to the City of Jacksonville and participating agencies. The participating agencies are City of Jacksonville (COJ), JEA, Jacksonville Port Authority (JPA), Duval County Public Schools (DCPS) and Jacksonville Airport Authority (JAA). JEA will utilize a variety of services provided by this solicitation to supply fuel for JEA's fleet of vehicles and equipment. These services include Retail Fuel Card Purchases, Bulk Fuel Delivery/Diesel Exhaust Fluid (DEF), Terminal Fueling for both diesel and unleaded gasoline, and Temporary Fixed Tanks (Totes) during Hurricane season.

JEA IFB/RFP/State/City/GSA#: COJ SC-0411-22

Purchasing Agent: Bayouth, Eddie

Is this a Ratification?: NO

RECOMMENDED AWARDEE(S):

Name	Contact Name	Email	Address	Award Amount
GATE FLEET SERVICES	Emilie Nix	Enix@gatefleet.com	9540 San Jose Boulevard Jacksonville, Florida 32241-3627	\$16,585,108.22
GATE FUEL SERVICES	Donna Ponder	Dponder@gatepetro.com	9540 San Jose Boulevard Jacksonville, Florida 32241-3627	\$3,031,312.93

Amount for entire term of Contract/PO: \$19,616,421.15

Award Amount for remainder of this FY: \$347,690.35

Length of Contract/PO Term: Five (5) Years w/One (1) – 1 Yr. Renewal

Begin Date (mm/dd/yyyy): 09/01/2022

End Date (mm/dd/yyyy): 08/31/2027

Renewal Options: YES - One (1) – 1 Yr. Renewal

JSEB Requirement: N/A – No JSEBs available

Background/Recommendations:

On July 27, 2022, the City of Jacksonville (COJ) executed Contract SC-0411-22 with Gate Fleet Services as part of a Joint Agency Fuel Supply Products, Fuel Cards, and Related Services solicitation. Fuel consumption for this solicitation was based on combined historical consumption data provided by each participating agency. This proposed award is to piggyback the award with City of Jacksonville (COJ) to provide fuel related services to JEA Fleet Services.

JEA Fleet Services over the last five (5) plus years has developed an optimized fuel strategy to best serve JEA’s needs to allow flexibility as our service model evolves. Those areas are:

1. After hours diesel wet hose fueling and DEF at service centers, provided by Jacobus;
2. COJ pump fueling locations, COJ purchases the fuel from Gate, JEA purchases from COJ;
3. Wet hose fueling of off-road equipment and generators using terminal loaded JEA fuel trucks, fuel purchased from Gate;
4. Vehicle operator purchases using Fleet Fuel cards at retail pump locations located throughout the JEA service territory, fuel and DEF purchased from Gate;
5. Temporary fixed tanks rentals during Hurricane season to ensure fuel is available to the JEA Fleet if there is infrastructure damage following a storm, fuel purchases from Gate.

This contract will support JEA’s Fleet Service’s terminal fueling, retail fueling, and bulk fueling services noted in items 3 – 5 along with an indirect impact to the COJ pump purchases as COJ depends on the same Gate Contract for fuel.

When comparing bid pricing to the previous contract, both are consistent in using OPIS rack rate pricing with a set mark-up, plus appropriate taxes. The mark-up per gallon increased from .0583 per gallon for all grades on the existing contract, to .079 per gallon for non-diesel grades and to .089 per gallon markup for diesel grades under this contract. The budget estimate and actual award amounts are based on Fleet’s average annual consumption using the current mark-up amounts. Due to inflated OPIS rates over the past six months Fleet Services is projected to be overbudget for FY22 and FY23 if the rates continue to remain high. Fleet Services has identified a line within the budget to cover these overages.

Request approval to award a piggyback contract to Gate Fleet Services for retail fuel card purchases in the amount of \$16,585,108.22 and to Gate Fuel Services for the purchase of Bulk Fuel Delivery/Diesel Exhaust Fluid (DEF), Terminal Fueling for both diesel and unleaded gasoline, and Temporary Fixed Tanks (Totes) in the amount of \$3,031,312.93, for a NTE amount of \$19,616,421.15, subject to the availability of lawfully appropriated funds.

Manager: Hightower, Justin - Manager, Fleet Services & Business Operations
Director: Brunell, Baley – Director, Facilities and Fleet Services
VP: McElroy, Alan - VP of Supply Chain and Operations Support

Stephen Datz 8/25/2022

Chairman, Awards Committee **Date**

Stephanie M. Nealy 8/25/2022

Budget Representative **Date**