

Welcome to the

JEA Awards Meeting

March 02, 2023, 10:00 AM EST

You have been joined to the meeting with your **audio muted** by default.

At the designated public comment time we will provide opportunity for you to unmute to speak.

During the meeting, public comments received via e-mail regarding any matter on the agenda for consideration will be read out. Per the Public Notice Agenda posted on JEA.com, public comments by e-mail must be received no later than 9:00 a.m. on the day of the meeting to be read during the public comment portion of the meeting.

Please contact **Aileen Cruz** by telephone at **(904) 703-0996** or by email at **cruza@jea.com** if you experience any technical difficulties during the meeting.



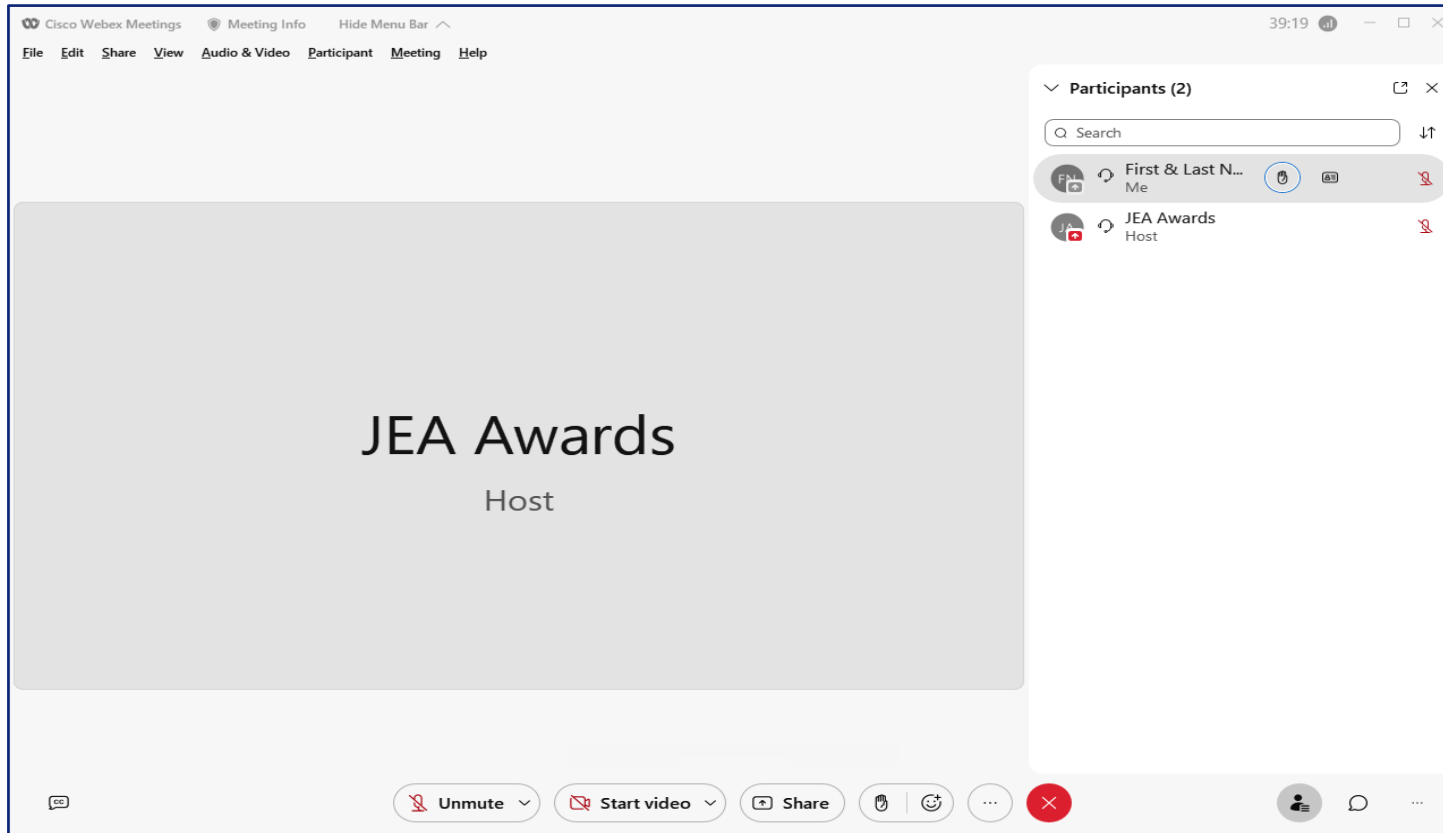

Awards Meeting – Public Comments



Controls for Public Comments

Located on the bottom-right side of your screen you will find an icon that looks like a person  labeled Participants. This option will allow you to see a long list of individuals who have joined today's meeting.

At the top of this list, your name will be visible and to the right you will notice a gray icon that looks like a hand .

If you click it, it will show a slash through the hand  letting us know that you would like to be recognized for comment, additionally you may click it again to lower your hand.

For those that may have called in directly, there are 2 additional ways that you can notify us that you would like to provide comment. The first is by **pressing *3** on your phone, which will raise your hand. The second way you may notify us is to **press *6** to unmute your line.

If you unmute your line, please state your name so that everyone may hear who is speaking before providing your comment.

Below is a summary of the meeting controls you will see at the bottom of your screen.

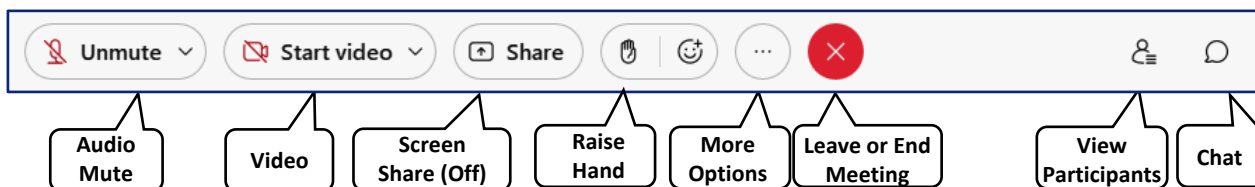

AWARDS COMMITTEE AGENDA

DATE: Thursday, March 2, 2023

TIME: 10:00 A.M.

PLACE: JEA, Customer Center, Bid Office, 1st Floor, 21 West Church Street, Jacksonville, FL
32202 OR
WebEx/Teleconference
WebEx Meeting Number (access code): 2309 526 2709
WebEx Password: cQMmJPHA823

Public Comments:

Awards:

1. Approval of the minutes from the last meeting(02/23/2023)
2. Request approval to award a one-year renewal to C&L Landscape Inc. for Restoration of Disturbed Sod in the amount of \$390,197.17, for a new not-to-exceed amount of \$2,109,560.67, subject to the availability of lawfully appropriated funds.
3. Request approval for a contract increase to Dis-Tran Packaged Substations, LLC for substation packaging services in the amount of \$2,827,192.00, for a new not-to-exceed amount of \$4,614,192.00, subject to the availability of lawfully appropriated funds
4. Request approval to award a change order to Carollo Engineers Inc. for additional design/engineering for the Buckman Biosolids Conversion Projects in the amount of \$1,086,707.24, for a new not-to-exceed amount of \$15,499,451.46, subject to the availability of lawfully appropriated funds.
5. Request approval to award a contract increase to Wharton-Smith, Inc. for equipment purchases and construction services as part of the Buckman Biosolids Conversion Projects in the amount of \$14,514,773.00, for a new not-to-exceed amount of \$65,369,174.27, subject to the availability of lawfully appropriated funds.
6. Request approval to award a two (2) year contract renewal to DLT Solutions, LLC for Data Integration Platform as a Service (PaaS) in the amount of \$399,377.21, for a not-to-exceed amount of \$947,367.02 subject to the availability of lawfully appropriated funds.
7. Request approval to award a contract to Kubota Membrane USA Corporation for the purchase of Nassau Regional WRF membranes and associated tubing in the amount \$535,192.00, subject to the availability of lawfully appropriated funds.
8. Request approval to award a contract renewal to Anixter Inc. for the supply of Electrical Conduit for JEA Inventory Stock in the amount of \$3,287,444.76, for a not-to-exceed amount of \$6,152,407.57, subject to the availability of lawfully appropriated funds.

Informational Items: N/A

Open Discussion: N/A

Public Notice: N/A

General Business: N/A

SPECIAL NOTES: Copies of the above items are available in JEA Procurement, if needed for review. If a person decides to appeal any decision made by the Awards Committee, with respect to any matter considered at this meeting, that person will need a record of the proceedings, and, for such purpose, needs to ensure that a verbatim record of the proceedings is made, which record includes the evidence and testimony upon which the appeal is to be based. If you have a disability that requires reasonable accommodations to participate in the above meeting, please call 665-8625 by 8:30 a.m. the day before the meeting and we will provide reasonable assistance for you.

03-02-2023 Awards Committee

<u>Award#</u>	<u>Type of Award</u>	<u>Business Unit</u>	<u>Estimated/ Budgeted Amount</u>	<u>Amount</u>	<u>Awardee</u>	<u>Term</u>	<u>Summary</u>
1	Minutes	N/A	N/A	N/A	N/A	N/A	Approval of minutes from the 02/23/2023 meeting.
2	RENEWAL	Vu	\$390,197.17	\$390,197.17	C&L LANDSCAPE INC.	Three Years w/ Two (2) - One (1) Year Renewals	<p><u>Restoration of Disturbed Sod (North/West) JSEB Sheltered Market</u></p> <p>The scope of work for this contract includes the restoration of sod in City, County and Florida Department of Transportation (FDOT) right of way and easements (the "Work"). The Work may also include hydro seeding, fill placement, moderate compacting, and removal and hauling of site debris and extra fill to another site. The Work will be in JEA service territory on the North and West side of the St. John's River to include parts of Nassau and Clay Counties.</p> <p>C&L Landscape, Inc. has performed well under this contract, and JEA desires to exercise the final one (1) year renewal as well as a contract increase of \$390,197.17. The increase amount is an estimate based on the previous year spend. The unit prices for the work will not increase for this renewal period.</p> <p>A new not-to-exceed amount of \$2,109,560.67.</p>
3	CONTRACT INCREASE	Melendez	\$2,827,192.00	\$2,827,192.00	DIS-TRAN PACKAGED SUBSTATIONS, LLC (A CREST INDUSTRIES, LLC COMPANY)	Three (3) Years w/ Two (2) - 1 Yr. Renewals	<p><u>Substation Packaging Services</u></p> <p>This solicitation is to select substation material packaging company(s) that will be contracted to provide structures, materials and other engineered equipment for JEA substation projects and/or small transmission projects that are incidental to substation projects. The company(s) shall perform and provide all design, detailing, documentation, procurement, manufacturing, scheduling, equipment selection, materials, project management and associated services for a turn-key, ready-to-install substation package of structures and materials to allow JEA to construct improvements to the JEA electric system.</p> <p>This request is to add funds for Capital projects in the amount of \$2,827,192.00, to allow continued use through the Original Term. The original award amount was based on historical usage and budget estimates available at the time of award.</p>

03-02-2023 Awards Committee

							<p>It should be noted that term-based services contracts are typically not funded for the latter years of the contract. Should additional work develop during the contract term, or should JEA elect to renew the contracts, additional funding may be required. Additional increases will be processed through the Awards Committee as necessary.</p> <p>A new not-to-exceed amount of \$4,614,192.00.</p>
4	CHANGE ORDER	Melendez	\$1,200,000.00	\$1,086,707.24	CAROLLO ENGINEERS INC.	Project Completion (Expected: January 2028)	<p><u>Buckman Biosolids Conversion Projects</u></p> <p>The Buckman Water Reclamation Facility (WRF) treats an average of 30 million gallons per day (MGD) of wastewater and processes waste activated sludge and primary sludge produced from eight (8) other JEA treatment plants. This award secures professional design and engineering services for multiple projects, including treatment and infrastructure improvements, at Buckman. The goal is to manage all proposed projects under one Consultant to provide clear oversight, better alignment of schedules and shorten project timelines. These capital improvements will result in Buckman having the necessary facilities and processes in place to produce biosolids to be utilized for beneficial purposes for the next 20+ years.</p> <p>This change order is for design changes that JEA is requesting. The design for the Raw Sludge Holding Tank (RSHT) at the 60% stage was based on reusing the existing RSHT. At the 60% design review meeting JEA decided it was necessary to demolish the existing tank and construct a new RSHT due to the age and condition of the existing RSHT. The new RSHT will be built at a different location at the plant due to potential settlement issues at the current location which cannot be studied until the demolition of the existing RSHT is complete. Relocating the new RSHT will provide Buckman WRF better options for biosolids treatment now and in the future while conserving space required for future facilities. JEA also decided to alter the current flow of sludge from Arlington East and the District II WRFs directly into the new RSHT which will make the thickening process easier to operate.</p> <p>A new not-to-exceed amount of \$15,499,451.46.</p>
5	CONTRACT INCREASE	Melendez	\$15,000,000.00	\$14,514,773.00	WHARTON-SMITH INC.	Project Completion (Expected: January 2028)	<p><u>Construction Management-at-Risk (CMAR) Services for the Buckman Biosolids Conversion Projects</u></p> <p>The scope of work to be performed under this solicitation consists of CMAR services for the Buckman Biosolids</p>

03-02-2023 Awards Committee

							<p>Conversion Projects. This project is needed to update the treatment process at the Buckman Water reclamation Facility (WRF) to meet current and future needs. The projects to be constructed are listed below:</p> <ol style="list-style-type: none"> 1. Biosolids Process Facility 2. Operations and Maintenance (O&M) Building 3. Ultraviolet (UV) Disinfection 4. Blower Improvements and Electrical Building <p>This contract increase is to approve an early Guaranteed Maximum Price (GMP) for plant underground mechanical work, the purchase of gravity belt thickening equipment, bridge cranes purchase and elevator procurement. This early work package will allow the purchase of long lead items to keep the project on schedule and allow the contractor to perform necessary underground mechanical work to keep the biosolids facility construction on schedule.</p> <p>JEA reviewed the CMAR GMP proposal and deemed the results reasonable when compared to past projects. As design progresses for the other aspects of the overall Buckman Biosolids Conversion Projects, additional GMPs will be brought before the Awards Committee. It is estimated that the overall contract value, inclusive of all projected projects, will be \$300,000,000.00.</p> <p>A new not-to-exceed amount of \$65,369,174.27.</p>
6	RENEWAL	Selders	\$500,000.00	\$399,377.21	DLT SOLUTIONS, LLC	Three (3) Years w/Two (2) - One (1) Yr. Renewals	<p><u>Data Integration Platform as a Service (PaaS)</u></p> <p>The purpose of this Invitation to Negotiate (the "ITN") for the data integration project is to evaluate and select a vendor that can provide a software tool to develop, manage, and maintain a modern data integration pipeline and facilitate accessibility to the data in a more secure and efficient manner.</p> <p>This request is for additional funding of \$399,377.21 for a two (2) year contract renewal for the original purchased product suite, from 04/01/2023 to 03/31/2025 to maintain the existing software subscription and support. DLT is an authorized reseller of the Informatica Suite of Tools that JEA is using to build and maintain JEA's Enterprise Data Warehouse for data analysis and reporting. DLT Solutions, LLC has performed well over the initial term of the contract and will keep rates the same for the two (2) year renewal.</p> <p>A not-to-exceed amount of \$947,367.02.</p>

03-02-2023 Awards Committee

7	SINGLE SOURCE	Vu	\$535,192.00	\$535,192.00	KUBOTA MEMBRANE USA CORPORATION	Project Completion (Estimated: April 2023)	<p><u>Kubota Membrane Changeout</u></p> <p>This scope of work is for the purchase of 5,600 membranes and associated tubing, in the Membrane Bio-Reactor (MBR) Basin #3 at the Nassau Regional Water Reclamation Facility (WRF). Permit compliance and the ability to meet reuse customer demands are at risk if the membranes are not replaced.</p> <p>The Nassau WRF MBR process was designed to utilize the Ovivo Membrane (sold through Kubota). The Nassau WRF is the only facility in JEA to use this membrane technology.</p> <p>Based on previous investigations with the manufacturer and the continuing operational experience of JEA, it has been determined that a five (5) year replacement cycle of the membranes is necessary to ensure continued operation of the plant in compliance with permit requirements. Since the membranes were replaced in FY19 there has been a 42% price increase (from \$376,600.00 to \$535,192.00). This increase is deemed reasonable in the current economic environment.</p> <p>Request approval to award a single source contract to Kubota Membrane USA Corporation for the purchase of Nassau Regional WRF membranes and associated tubing in the amount \$535,192.00.</p>
8	CONTRACT RENEWAL	McElroy	\$3,287,444.76	\$3,287,444.76	ANIXTER INC.	One (1) Year w/Two (2) – One (1) Yr. Renewals	<p><u>Electrical Conduit for JEA Inventory Stock Contract Renewal</u></p> <p>The purpose of this award is to exercise the final one (1) year renewal, with an increase in the dollar amount of the contract for Electrical Conduit for JEA Inventory Stock, to cover the remaining existing term and the renewal term. This agreement provides electrical conduit materials consisting of forty-seven (47) items for JEA Inventory Stock and Storm Stores. These items are used for providing underground utilities throughout the JEA system.</p> <p>PVC conduit is a critical component in the JEA underground utility service. The proposed execution of the last contract renewal of one (1) year term and contract increase is needed to fully fund the estimated purchases of PVC conduit through 08/31/2024. The proposed award amount for Anixter Inc. is based upon future forecasts, the current price of materials, and orders placed to date. These increases are based primarily on three factors, the first and primary factor has been an increase in PVC pricing directly linked to PVC resin costs, which are the primary cost driver of the finished PVC pipe costs. JEA</p>

03-02-2023 Awards Committee

							<p>has experienced a 35% increase since the first renewal conducted in June of 2022, driven from PVC resin cost increases linked to adjustments per contract based on Chemical Data, Inc. index data.</p> <p>The second factor in the annual projected spend has been attributed to an increase in demand based on new underground utility development within the JEA service territory. The amount proposed does not account for upwards or downwards price adjustments that align PVC resin indices values and finished goods pricing in accordance with contract and solicitation adjustment language, for orders that will occur in the future. Lastly, adding the additional one (1) year of term adds estimated usage to the overall value of the contract.</p> <p>A new not-to-exceed amount of \$6,152,407.57.</p>
Total Award				\$23,040,883.38			

JEA AWARDS COMMITTEE FEBRUARY 23, 2023, MEETING MINUTES

The JEA procurement Awards Committee met on February 23, 2023, in person with a WebEx option.

WebEx Meeting Number (access code): 2309 526 2709

WebEx Password: cQMmJPHA823

Members in attendance were Jenny McCollum as Chief Procurement Officer, Stephen Datz as Chairperson (onsite), Stephanie Nealy as Budget Representative, Rebecca Lavie as Office of General Counsel Representative, Hai Vu as Vice Chairperson, Janie Smalley for Laura Schepis (onsite), Joe Orfano (onsite), and Ricky Erixton (onsite). Unless otherwise indicated, all attendees were via WebEx.

Chair Datz called the meeting to order at 10:02 a.m., introduced the Awards Committee Members, and confirmed that there was an in-person quorum of the Committee membership present.

Public Comments:

Chair Datz recognized the public comment speaking period and opened the meeting floor to public comments. No public comments were provided by email, phone or videoconference.

Awards:

1. Approval of the minutes from the last meeting (02/16/2023). Chair Datz verbally presented the Committee Members the proposed February 16, 2023, minutes as presented

MOTION: Joe Orfano made a motion to approve the February 16, 2023, minutes (Award Item 1) as presented in the committee packet. The motion was seconded by Janie Smalley and approved unanimously by the Awards Committee (5-0).

The Committee Members reviewed and discussed the following Awards Items 1-5.

2. 1410820046 – Request approval to award a contract to Carollo Engineers, Inc. for engineering and services during construction for the Oakridge WTP Upgrade projects in the amount of \$1,227,949.36, subject to the availability of lawfully appropriated funds.

MOTION: Janie Smalley made a motion to approve Award Item 2 as presented in the committee packet. The motion was seconded by Joe Orfano and approved unanimously by the Awards Committee (5-0).

3. Request 1410975046 – Request approval to award a contract to Sawcross, Inc. for construction services for the Twin Creeks Pump Station Upgrades in the amount of \$9,933,000.00, subject to the availability of lawfully appropriated funds.

MOTION: Ricky Erixton made a motion to approve Award Item 3 as presented in the committee packet. The motion was seconded by Hai Vu and approved unanimously by the Awards Committee (5-0).

4. 1410943246 – Request approval of purchase from CARS-DB5, L.P., Delaware limited partnership, for the subject property – Easement Acquisition Purchase in the amount of \$150,000.00, subject to the availability of lawfully appropriated funds.

MOTION: Joe Orfano made a motion to approve Award Item 4 as presented in the committee packet. The motion was seconded by Janie Smalley and approved unanimously by the Awards Committee (5-0).

5. 1410937446 – Request approval to award a contract to E-Builder, Inc. for Project Management Information System

(PMIS) Software Licensing, Support, and Implementation in the amount of \$913,700.00, subject to the availability of lawfully appropriated funds.

MOTION: Hai Vu made a motion to approve Award Item 5 as presented in the committee packet. The motion was seconded by Joe Orfano and approved unanimously by the Awards Committee (5-0).

Informational Item:

No informational items were presented to the Awards Committee.

Ratifications:

No ratifications were presented to the Awards Committee.

Public Comments:

No additional public comment speaking period was taken.

Adjournment:

Chair Datz adjourned the meeting at 10:12 a.m.

NOTE: These minutes provide a brief summary only of the Awards Committee meeting. For additional detail regarding the content of these minutes or discussions during the meeting, please review the meeting recording. The recording of this meeting as well as other relevant documents can be found at the link below:
https://www.jea.com/About/Procurement/Awards_Meeting_Agendas_and_Minutes/



Formal Bid and Award System

Award #2 March 2, 2023

Type of Award Request: RENEWAL
Requestor Name: Schoettler, Kyle
Requestor Phone: (904) 524-3989
Project Title: Restoration of Disturbed Sod (North/West) JSEB Sheltered Market
Project Number: Capital: 8008313, 8008317; O&M: HW30601Line 866
Project Location: JEA
Funds: Capital and O&M
Business Unit Estimate: \$390,197.17

Scope of Work:

The scope of work for this contract includes the restoration of sod in City, County and Florida Department of Transportation (FDOT) right of way and easements (the “Work”). The Work may also include hydro seeding, fill placement, moderate compacting, and removal and hauling of site debris and extra fill to another site. The Work will be in JEA service territory on the North and West side of the St. John’s River to include parts of Nassau and Clay Counties.

JEA IFB/RFP/State/City/GSA#: 046-19
Purchasing Agent: King, David
Is this a Ratification?: NO

RECOMMENDED AWARDEE(S):

Name	Contact Name	Email	Address	Phone	Amount
C&L LANDSCAPE INC.	Tana Hamburger	tana@cclandscape.com	1601 E Duval St, Jacksonville FL 32202	(904) 353-6620	\$390,197.17

Amount of Original Award: \$1,021,375.00
Date of Original Award: 03/14/2019
Contract Increase Amount: \$390,197.17

List of Previous Change Order/Amendments:

CPA #	Amount	Date	Reason
181000	\$102,137.50	07/02/2021	Administrative increase due to un-forecasted work increases
181000	\$595,851.00	02/17/2022	Awarded contract renewal and funding increase

New Not-To-Exceed Amount: \$2,109,560.67
Length of Contract/PO Term: Three Years w/ Two (2) - One (1) Year Renewals
Begin Date: 03/28/2019
End Date: 03/27/2024
Renewal Options: None Remaining
JSEB Requirement: JSEB Sheltered
Notes on JSEB Requirement:



Formal Bid and Award System

Award #10 February 17, 2022

Type of Award Request: CONTRACT INCREASE & RENEWAL

Requestor Name: Schoettler, Kyle C.

Requestor Phone: (904) 665-8946

Project Title: Restoration of Disturbed Sod (North/West) JSEB Sheltered Market

Project Number: Various

Project Location: JEA

Funds: Capital and O&M

Budget Estimate: \$595,851.00

Scope of Work:

JEA is soliciting bids from qualified Jacksonville Small and Emerging Business (JSEB) vendors for the restoration of sod in City, County and Florida Department of Transportation (FDOT) rights of way and easements (the "Work"). The Work may also include hydro seeding, fill placement, moderate compacting, and removal and hauling of site debris and extra fill to another site. The Work will be in JEA's service territory on the South and East sides of the St. John's River.

JEA IFB/RFP/State/City/GSA#: 046-19

Purchasing Agent: Brown, Darriel D.

Is this a Ratification?: YES - Partial

\$143,000.00 to cover pending work orders

RECOMMENDED AWARDEE(S):

Name	Contact Name	Email	Address	Phone	Amount
C & L LANDSCAPE, INC.	Tana Hamburger	tana@cllandscape.com	1601 E Duval St, Jacksonville FL 32202	(904) 353-6620	\$595,851.00

Amount of Original Award: \$1,021,375.00

Date of Original Award: 07/09/2018

Change Order Amount: \$595,851.00

List of Previous Change Order/Amendments:

CPA #	Amount	Date
181000	\$102,137.50	07/02/2021
181000	\$143,000.00	12/17/2021

New Not-To-Exceed Amount: \$1,719,363.50

Length of Contract/PO Term: Three Years w/ Two (2) – 1 Yr. Renewals

Begin Date: 03/28/2019

End Date: 03/27/2023

Renewal Options: Yes - One (1) - 1 Yr. Renewal

JSEB Requirement: JSEB Sheltered

Comments on JSEB Requirements:

C & L Landscape, Inc. is a JSEB

Background/Recommendations:

Originally competitively bid and awarded on 03/14/2019 in the amount of \$1,021,375.00. An administrative increase was approved on 07/02/2021 in the amount of \$102,137.50 due to increases in repair work in the service area. A copy of the previous award document is attached for reference.

C & L Landscape, Inc. has performed well under this contract and JEA desires to exercise the available one (1) year renewal up to the budget of \$595,851.00. This amount includes a ratification of \$143,000.00. The budget has been increased due to increased repair activities in this service area. JEA originally planned on rebidding this contract with the South/East service territory contract to better align their scheduled beginning and end dates. Upon further consideration, and due to current inflationary market conditions, it was instead decided to exercise the renewal option at the current contract rates.

Request approval to award a ratification of \$143,000, a renewal, and a contract increase to C & L Landscape, Inc. in the amount of \$452,851.00, for a new not-to-exceed of \$1,719,363.50, subject to the availability of lawfully appropriated funds.

Director: Scheel, Jackie B. - Dir W/WW Reuse Delivery & Collection

VP: Vu, Hai X. - VP Water Wastewater Systems

APPROVALS:

Chairman, Awards Committee **Date**

Budget Representative **Date**



Formal Bid and Award System

Award #2 March 14, 2019

Type of Award Request: BID (IFB)
Request #: 6459
Requestor Name: Smith, Thaliah D. – Contract Specialist
Requestor Phone: (904) 665-8165
Project Title: Restoration of Disturbed Sod (North/West) JSEB Sheltered Market
Project Number: 8005184, 8005119, 8005153, 8005179
Project Location: JEA
Funds: Capital and O&M (line 411)
Budget Estimate: \$1,020,000.00 (50% Capital, 50% O&M)

Scope of Work:

JEA is soliciting bids from qualified Jacksonville Small and Emerging Business (JSEB) vendors for the restoration of sod in Municipal, City, County and Florida Department of Transportation (FDOT) rights of way and easements (the “Work”). The Work may also include hydro seeding, fill placement, moderate compacting, and removal and hauling of site debris and extra fill to another site. The Work will be in JEA service territory on the North and West side of the St. John’s River to include parts of Nassau and Clay Counties.

This award will impact the following Measures of Value:

- Community Impact Value: This contract will restore customer lawns to the pre-maintenance/pre-construction state or better.

JEA IFB/RFP/State/City/GSA#: 046-19
Purchasing Agent: Kruck, Daniel R.
Is this a Ratification?: NO

RECOMMENDED AWARDEE(S):

Name	Contact Name	Email	Address	Phone	Amount
C & L LANDSCAPE INC.	Tana Hamburger	tana@cclandscape.com	1601 E Duval St, Jacksonville FL 32202	(904) 353-6620	\$1,021.375.00

Amount for entire term of Contract/PO: \$1,021,375.00
Award Amount for remainder of this FY: \$170,229.17
Length of Contract/PO Term: Three Years w/ Two (2) - One (1) Year Renewals
Begin Date (mm/dd/yyyy): 03/28/2019
End Date (mm/dd/yyyy): 03/28/2022
Renewal Options: Yes, Two (2) - One (1) Year Renewals
JSEB Requirement: JSEB Sheltered
Comments on JSEB Requirements:

C&L Landscaping Inc. is a JSEB

BIDDERS:

Name	Amount
C&L LANDSCAPE INC.	\$1,021,375.00
KIRBY DEVELOPMENT, INC.	\$4,818,608.59

Background/Recommendations:

Advertised on 01/10/2019. Five (5) prime contractors attended the mandatory pre-bid meeting held on 01/22/2019. At Bid opening on 02/12/2019, JEA received two (2) Bids. Prior to the solicitation advertisement JEA conducted a JSEB workshop reviewing the scope of work for this solicitation in an attempt to increase participation. After bid opening companies that attended the pre-bid, but did not submit stated a lack of experience in this type of sod contract, as the reason for not submitting a bid. C&L Landscape Inc. is the lowest responsive and responsible Bidder. A copy of the bid form and workbook are attached as backup.

The award amount of \$1,021,375.00 is approximately 0.13% higher than the budget estimate and deemed reasonable. This pricing is approximately three percent (3%) lower than a similar contract for sod restoration services with American Construction Enterprises for JEA’s service territory on the South and East sides of the St. John’s River. The work for this contract will be completed on a task order basis, and payments will be made in accordance with the unit prices on the bid workbook. The unit prices are fixed for one (1) year then may be increased via a Consumer Price Index (CPI) adjustment. The quantities on the bid workbook used to determine the award total are based on JEA’s historical task order volume over the past three years for this service territory. It should be noted that the original bid amount from C&L Landscape Inc. was \$1,148,005.00. Due to the higher than estimated unit prices JEA negotiated with C&L Landscape Inc. for a savings of \$126,630.00.

046-19 – Request approval to award a contract to C&L Landscape Inc. for Restoration of Disturbed Sod in the amount of \$1,021,375.00, subject to the availability of lawfully appropriated funds.

Manager: Schoettler, Kyle C. - Mgr W/WW System Operations & Customer Response
Director: Scheel, Jackie B. – Dir W/WW Reuse Delivery & Collection
VP: Calhoun, Deryle I. - VP/GM Water Wastewater Systems

APPROVALS:

Chairman, Awards Committee **Date**

Manager, Operating Budgets **Date**



Formal Bid and Award System

Award #3 March 2, 2023

Type of Award Request: CONTRACT INCREASE
Requestor Name: Smith, Brandy L. – Electric Systems Engineer
Requestor Phone: 904-665-7987
Project Title: Substation Packaging Services
Project Number: 8008477
Project Location: JEA
Funds: Capital
Business Unit Estimate: \$2,827,192.00

Scope of Work:

This solicitation is to select substation material packaging company(s) that will be contracted to provide structures, materials and other engineered equipment for JEA substation projects and/or small transmission projects that are incidental to substation projects. The company(s) shall perform and provide all design, detailing, documentation, procurement, manufacturing, scheduling, equipment selection, materials, project management and associated services for a turnkey, ready-to-install substation package of structures and materials to allow JEA to construct improvements to the JEA electric system.

Where design and engineering scopes exceed the requirements of Florida Statute 287.055 for the Competitive Consultants Negotiation Act (CCNA), projects will be solicited independently of this contract in accordance with statute & JEA P-Code requirements.

JEA IFB/RFP/State/City/GSA#: 1410617246
Purchasing Agent: Lovgren, Rodney Dennis
Is this a ratification?: NO

RECOMMENDED AWARDEE:

Name	Contact Name	Email	Original Award	Contract Increase	New NTE
DIS-TRAN PACKAGED SUBSTATIONS, LLC (A CREST INDUSTRIES, LLC COMPANY)	Richard Delizza	richarddd@electricsalesinc.com	\$1,250,900.00	\$2,827,192.00	\$4,614,192.00
SUBSTATION ENTERPRISES, INC.	Kurt Edwards, P.E.	kurt@subenterprises.com	\$536,100.00	\$0.00	\$536,100.00

Amount of Original Award: \$1,787,000.00
Date of Original Award: 12/08/2022
Change Order Amount: \$2,827,192.00
New Not-To-Exceed Amount: \$4,614,192.00
Length of Contract/PO Term: Three (3) Years w/ Two (2) - 1 Yr. Renewals
Begin Date (mm/dd/yyyy): 12/30/2022
End Date (mm/dd/yyyy): 12/29/2025
Renewal Options: Yes – Two (2) – 1 Yr. Renewals
JSEB Requirement: NA – Optional



Formal Bid and Award System

Award #4 December 8, 2022

Type of Award Request: REQUEST FOR PROPOSAL (RFP)
Requestor Name: Smith, Brandy L. – Electric Systems Engineer
Requestor Phone: 904-665-7987
Project Title: Substation Packaging Services
Project Number: (See attachment)
Project Location: JEA
Funds: Capital
Business Unit Estimate: \$1,787,000.00

Scope of Work:

This solicitation is to select substation material packaging company(s) that will be contracted to provide structures, materials and other engineered equipment for JEA substation projects and/or small transmission projects that are incidental to substation projects. The company(s) shall perform and provide all design, detailing, documentation, procurement, manufacturing, scheduling, equipment selection, materials, project management and associated services for a turn-key, ready-to-install substation package of structures and materials to allow JEA to construct improvements to the JEA electric system.

Where design and engineering scopes exceed the requirements of Florida Statute 287.055 for the Competitive Consultants Negotiation Act (CCNA), projects will be solicited independently of this contract in accordance with statute & JEA P-code requirements.

JEA IFB/RFP/State/City/GSA#: 1410617246
Purchasing Agent: LOVGREN, RODNEY D.
Is this a Ratification?: NO

RECOMMENDED AWARDEE(S):

Name	Contact Name	Email	Address	Phone	Amount
DIS-TRAN PACKAGED SUBSTATIONS, LLC (A CREST INDUSTRIES, LLC COMPANY)	Richard Delizza	richarddd@electricsalesinc.com	4725 Hwy 28 East Pineville, LA 71360	954-385-8885	\$1,250,900.00
SUBSTATION ENTERPRISES, INC.	Kurt Edwards, P.E.	kurt@subenterprises.com	145 Commercial Ct. Alabaster, AL, 35007	(205) 685-2755 x 103	\$536,100.00

Amount for entire term of Contract/PO: \$1,787,000.00
Award Amount for remainder of this FY: \$1,787,000.00
Length of Contract/PO Term: Three (3) Years w/ Two (2) - 1 Yr. Renewals
Begin Date (mm/dd/yyyy): 12/30/2022

End Date (mm/dd/yyyy): 12/29/2025
Renewal Options: Yes – Two (2) – 1 Yr. Renewals
JSEB Requirement: N/A - Optional

PROPOSERS:

Name	Rank
DIS-TRAN PACKAGED SUBSTATIONS, LLC (A CREST INDUSTRIES, LLC COMPANY)	1
SUBSTATION ENTERPRISES, INC.	2

Background/Recommendations:

Advertised on 04/29/2022. Three (3) prime companies attended the optional pre-proposal meeting held on 05/13/2022. At proposal opening on 08/16/2022, JEA received two (2) Proposals. The public evaluation meeting was held on 10/05/2022. Companies were evaluated on professional staff experience, design & work approach, company experience, proximity and JSEB content. JEA deemed Dis-Tran Packaged Substations, LLC and Substation Enterprises, Inc. as the highest evaluated companies to perform the work. A copy of the evaluation matrix and negotiated rate structures are attached as backup.

For continuing services contracts, JEA bases contract not-to-exceed amounts based on a list of current approved project budgets. JEA will preliminarily fund the contract and will return to Awards Committee to add funds to the contracts to fund work as projects are released and scopes of work are determined.

The engineering services group will issue task orders as required to facilitate the work. The work may be bid by both companies and awarded to the lowest bidder between the two, or specifically awarded to one company on a cost-plus basis to the highest evaluated company.

Previously JEA’s negotiated rate structure contained rates for manufacturing, steel structure & galvanization on price-per-pound and price-per-foot rates, with indices for periodic adjustment and mark-up on purchased materials. For this solicitation, JEA has agreed to a cost-plus approach for both manufacturing (steel structures) and purchased materials, which is subject to audit by the PM. Transportation is a pass-through cost. The markup for Dis-Tran is 30% and Substation Enterprises is tiered based on project size (spend amount) and ranges from 25% for smaller projects to 14% for larger projects. Since there is not a specific priced project yet, JEA does not have a specific comparison; however, in the previous contract Dis-Tran’s mark-up was 25% for purchase materials. Considering today’s market conditions, the approach to pricing and contracting is deemed reasonable.

1410617246 – Request approval to award contracts to Dis-Tran Packaged Substations, LLC (\$1,250,900.00) and Substation Enterprises, Inc. (\$536,100.00) for substation packaging services in the not-to-exceed amount of \$1,787,000.00, subject to the availability of lawfully appropriated funds.

Manager: Hamilton, Darrell D. - Mgr Transmission and Substation Projects
Director: Acs, Gabor - Sr Dir Engineering & Projects
VP: Melendez-Melendez, Pedro A. - VP Planning Engineering & Construction

APPROVALS:

Stephen Datz 12/08/2022

Chairman, Awards Committee **Date**

Stephanie M Nealy 12/08/2022

Budget Representative **Date**

<u>FY23</u>	<u>Substation Packager Estimate</u>	<u>OPN</u>
SJRPP 230-26kV Distribution Substation	\$ 500,000.00	8007818
Ribault 138-26 kV T2 and Circuit Breaker 452 Addition	\$ 160,000.00	8007634
St Johns 4kV Rebuild	\$ 23,000.00	8006861
Normandy Substation - New Control House	\$ -	8007704
Starratt 138-26kV T2 Addition - Substation	\$ 412,000.00	788-151
West Jax 230/69kV Substation Reliability Improvement	\$ 127,000.00	788-158
Imeson 138-26kV T2 Addition	\$ 500,000.00	8007831
Kennedy TP7SU 69/4 kV Transformer Replacement	\$ -	8007939
Lane Ave T2 69/27 kV Transformer Replacement	\$ -	8007917
Northside T17 138/27 kV Transformer Replacement	\$ -	8007918
West Jax T1 230/69 kV Autotransformer Replacement	\$ -	8007956
College Street Switchgear Replacement	\$ 10,000.00	8008424
Waters Street T2 Replacement	\$ 20,000.00	8008427
Waters Street Compressor Replacement	\$ 10,000.00	8008428
Imeson Center Switch 5395 Replacement	\$ 25,000.00	8008211
Total	\$ 1,787,000.00	

<u>FY24</u>	<u>Substation Packager Estimate</u>
Nocatee T2 Circuit 239, 240, 241 Addition	
New World Substation - Substation	
GEC 230kV Bay & Breaker Addition for Circuit 950	
Mayo Sub 230 kV Addition-phase 2	
West Jax T3 200 MVA Autotransformer Addition	

<u>FY25</u>	<u>Substation Packager Estimate</u>
Pecan Park Area Substation	
Eagle LNG 138-13.8 kV Substation	

\$1,787,000

Distran (70%)

\$1,250,900.0

Substation Enterprises (30%)

\$536,100.0

Distran - JEA Pricing Structure

Material Price Sheet			
Description	Cost	Unit Mark Ups	Extended Prices
Steel Cost	\$ 400,000	30.0%	\$ 520,000
Equipment & Material Cost	\$ 200,000	30.0%	\$ 260,000
Subcontract Mark-Up	\$ 200,000	30.0%	\$ 260,000
Total Material Amount	\$ 800,000		\$ 1,040,000

Items will be estimated at the beginning of every project.

Items will be trued up at the end of every project.

Mutiple quotes will be obtained to determine best price and lead time.

Vendor invoices will be sent with customer invoices.

* Engineering Fee's not broken out as billable hours...

Material and Services Sub-Total			\$ 1,040,000
--	--	--	---------------------

Estimated Freight (PP&A)			\$ 360,000
-------------------------------------	--	--	-------------------

Marshal/Vendor freight will be estimated and passed through to JEA

Freight invoices will be sent with customer invoices.

Total Contract Amount			\$ 1,400,000
------------------------------	--	--	---------------------

Pricing is valid for material and services scope listed above. Deviations to this scope may cause price adjustments.

Payment Miestones: Based off of Material and Services Sub Total Listed Above.

Milestone 1: 30% Procurement of Long Lead Time Material

Milestone 2: 70% Delivery

Milestone 2 percentage subject to change based off of final material cost after all drawings are approved

* What is the index that the steel material is subject to change by?

* Other purchased materials cost.

Substation Enterprises, Inc.

November 30, 2022

Mr. Rodney Lovgren
Purchasing Agent Senior
Jacksonville Electric Authority
21 West Church Street
Jacksonville, FL 32202

Dear Mr. Lovgren:

This letter is in response to your e-mail of Friday, October 21, 2022. It is our proposal that substation packages we supply to you are provided at different margin percentage (as a percentage of selling price) based on the total substation package price. We would take your conceptual drawings and write a detailed bill of material for the materials (including structural steel) that are required for a specific substation package. We would like to propose the following scale with all freight passed through with no markup:

\$0 - \$100,000 – margin percentage to be 25% of selling price

\$100,000 - \$350,000 - margin percentage to be 20% of selling price

\$350,000 - \$600,000 - margin percentage to be 18% of selling price

\$600,000 - \$800,000 – margin percentage to be 16% of selling price

\$800,000 and up – margin percentage to be 14% of selling price

With these margins, our engineering work is included to take your conceptual drawings and produce structural calculations, anchor bolt plans, foundation details (if required), grounding plans, key-marked electrical layouts, erection drawings, and steel detail (fabrication) drawings. We are not set up to track our engineering time separately. We will provide copies of our suppliers' invoices on JEA projects to verify our cost basis. We have a blanket agreement with our standard shape steel fabricator to provide hot-dip galvanized, fabricated structural steel products. Our standard payment terms are net 30 days after invoice date.

We can store small equipment and structural steel at no charge as long as we can invoice and get paid for projects we have complete and are holding for JEA. Large equipment (switches, large instrument transformers, etc.) and tapered tubular steel we will have to negotiate on a case-by-case basis.

Please let me know if this is acceptable. We look forward to working with you.

Sincerely,

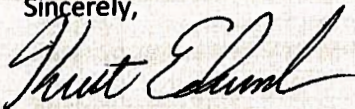

Kurt Edwards, P.E.

Vice-President

#	1410617246 Substation Packager Engineering Services									
	Vendor Rankings	Smith	Szoke	Roh	Average of Absolute	Average of Absolute	Σ Rank	Rank	Total Score	Historical Work
1	Distran	1	1	2	1	1	4	1	254.5	
2	Substation Enterprises Inc.	2	2	1	2	2	5	2	252.5	
#	Smith	Professional Staff Experience (25 Points)	Design Approach (20)	Company Experience (45 Points)	Proximity (5 Points)	JSEB (5 Points)		Total	Rank	
1	Distran	22.8	18.0	41.0	3	0		84.8	1	
2	Substation Enterprises Inc.	22.5	18.0	38.0	5	0		83.5	2	
	Szoke	Professional Staff Experience (25 Points)	Design Approach (20)	Company Experience (45 Points)	Proximity (5 Points)	JSEB (5 Points)		Total	Rank	
1	Distran	21.3	19.0	42.0	3	0		85.3	1	
2	Substation Enterprises Inc.	20.5	19.0	39.0	5	0		83.5	2	
	Roh	Professional Staff Experience (25 Points)	Design Approach (20)	Company Experience (45 Points)	Proximity (5 Points)	JSEB (5 Points)		Total	Rank	
1	Distran	23.5	18.0	40.0	3	0		84.5	2	
2	Substation Enterprises Inc.	22.5	19.0	39.0	5	0		85.5	1	
	Overall Averages	Professional Staff Experience (25 Points)	Design Approach (20)	Company Experience (45 Points)	Proximity (5 Points)	JSEB (5 Points)		Total		
1	Distran	22.50	18.33	41.00	3.00	0.00		84.83		
2	Substation Enterprises Inc.	21.83	18.67	38.67	5.00	0.00		84.17		

<u>FY23</u>	<u>OPN</u>	<u>Original Award 12/8/2022</u>	<u>Contract Increase 1</u>
SJRPP 230-26kV Distribution Substation	8007818	\$ 500,000.00	
Ribault 138-26 kV T2 and Circuit Breaker 452 Addition	8007634	\$ 160,000.00	
St Johns 4kV Rebuild	8006861	\$ 23,000.00	
Normandy Substation - New Control House	8007704	\$ -	
Starratt 138-26kV T2 Addition - Substation	788-151	\$ 412,000.00	
West Jax 230/69kV Substation Reliability Improvement	788-158	\$ 127,000.00	
Imeson 138-26kV T2 Addition	8007831	\$ 500,000.00	
Kennedy TP7SU 69/4 kV Transformer Replacement	8007939	\$ -	
Lane Ave T2 69/27 kV Transformer Replacement	8007917	\$ -	
Northside T17 138/27 kV Transformer Replacement	8007918	\$ -	
West Jax T1 230/69 kV Autotransformer Replacement	8007956	\$ -	
College Street Switchgear Replacement	8008424	\$ 10,000.00	
Waters Street T2 Replacement	8008427	\$ 20,000.00	
Waters Street Compressor Replacement	8008428	\$ 10,000.00	
Imeson Center Switch 5395 Replacement	8008211	\$ 25,000.00	
Eagle 138-13.8kV substation project.		\$ -	\$ 1,696,315.00
Total		\$ 1,787,000.00	
<u>FY24</u>			
Nocatee T2 Circuit 239, 240, 241 Addition			
New World Substation - Substation			
GEC 230kV Bay & Breaker Addition for Circuit 950			
Mayo Sub 230 kV Addition-phase 2			
West Jax T3 200 MVA Autotransformer Addition			
Eagle 138-13.8kV substation project.		\$ -	\$ 1,130,877.00
<u>FY25</u>			
Pecan Park Area Substation			
Eagle LNG 138-13.8 kV Substation			

Subtotal Award Increase			\$ 2,827,192.00
Total Award Amount NTE (Both Companies)		\$ 1,787,000.00	\$ 4,614,192.00
Distran (70%)		\$ 1,250,900.00	\$ 4,078,092.00
Substation Enterprises (30%)		\$ 536,100.00	\$ 536,100.00



4725 Hwy 28E

Pineville, LA 71360

P: (318) 448-0274

F: (318) 445-7240

distransubstations.com

Proposal for 138/13.8KV Eagle Substation

DTPS Proposal: 104793 | DTPS Doc: 104793PD03 | Submitted Via Email | Date 2/7/2023

JEA

Proposal Amount(s) & Notes:

Substation Materials Cost: \$2,585,322.00

Contingency (10% Material Cost): \$198,870.00

Estimated Marshall/Vender Freight: \$43,000.00

Estimated Total Contract Value: \$2,827,192.00

****Freight is Pre-Paid & Add to invoice****

****See attached Pricing Spreadsheet****

Proposal Type:

Cost Plus - This proposal is priced based on costs plus specific fees, described below.

This correspondence is intended to serve as DIS-TRAN's proposal to provide goods and services in support of the above referenced project. Please carefully review this document in its entirety, including all attachments, as part of your comprehensive evaluation of our proposal. We are confident you will find our proposal to be both technically sound and competitively priced. We appreciate your consideration of our proposal and greatly look forward to working with you on this very important project. Please do not hesitate to contact me to discuss any portion of this proposal in further detail.

Proposal Contents:

- Terms
- Scope of Work
- Material Delivery
- Clarifications
- Scheduling

Sincerely,



Laine Stoute
Proposal Coordinator
Laine.Stoute@distran.com
Direct: (318) 767.5621 Mobile: (318) 880.2580

TERMS

(All checked items are included in or apply to this proposal)

- Freight Cost: Included or pre-paid and added to the invoice.
- Freight terms: FOB jobsite with the use of common carriers or EX-Works Factory or
- Pricing and scheduling shown above is for a complete package. Partial orders may require us to re-evaluate pricing.
- Payment Terms are net 30 days from submittal of invoices; a 1½% service charge will be applied to all overdue balances for each
- This proposal is valid for 15 days.
- All commercial terms per JEA contract "JEA11286".

ADDER/DEDUCT OPTIONS

Please note that option prices listed are not included in the proposal amount listed on page one.

ITEM	QTY	UNIT PRICE	TOTAL PRICE

SCOPE OF WORK: PROFESSIONAL ENGINEERING AND DESIGN SERVICES

All included Engineering/Design services will be sealed by a Professional Engineer registered in the jurisdiction in which the project is located.

ITEM	SERVICE	COMMENTS	SUBMITTAL ARO/ARAD (WEEKS)	DELIVERY DATE
S1	<input checked="" type="checkbox"/> <p>Structural Calculations, Foundation Reactions, Anchor Bolt Details (Standard Shape Structures)</p> <p>To appropriately size structural systems to support substation equipment and materials to meet or exceed jurisdictional building codes, industry standards, and customer specifications. Includes furnishing base reactions and anchor bolt requirements to serve as inputs for foundation design.</p>	Approval required No clarifications	19 weeks ARO	
S2	<input checked="" type="checkbox"/> <p>Structural Calculations, Foundation Reactions, Anchor Bolt Details (Tapered Tubular Structures)</p> <p>See description above.</p>	Approval required No clarifications	19 weeks ARO	
S3	<input checked="" type="checkbox"/> <p>General Arrangement Drawings, Material List, Product Data Sheets</p> <p>To identify the substation layout, fit and specifications of each component and sub-assembly; used by project owners, contractors, manufacturers and installers.</p>	Approval required No clarifications	23 weeks ARO	
S5	<input checked="" type="checkbox"/> <p>Major Equipment Drawings</p> <p>To provide the technical specifications, as well as construction, assembly and installation instructions via equipment drawings and literature.</p>	No approval needed No clarifications	8 weeks ARO	
S6	<input checked="" type="checkbox"/> <p>Structural Shop Drawings (Standard Shape Structures)</p> <p>To provide detailed drawings of structural members used in the fabrication process.</p>	Approval required No clarifications	23 weeks ARO	
S7	<input checked="" type="checkbox"/> <p>Structural Shop Drawings (Tapered Tubular Structures)</p> <p>See above description.</p>	Approval required No clarifications	23 weeks ARO	
S8	<input checked="" type="checkbox"/> <p>Complete Final Drawing Package</p> <p>Prior to material delivery, DIS-TRAN issues a comprehensive final drawing package complete with all DIS-TRAN generated drawings, vendor equipment drawings, data sheets, material lists and test reports generated through the design of the project</p>	No approval needed No clarifications	2-3 weeks before delivery	
S9	<input type="checkbox"/> <p>See Additional Items on Clarifications Page</p>			

Notes:

This schedule is also based on receipt of all applicable information (customer provided equipment drawings, equipment specifications, etc.) within one (1) week(s) of a notice to proceed.

This schedule allows for a five work-day turn-around time on submittals, not to exceed one (1) round of customer driven modifications. Please note that the overall lead-time for this project is 37-51 weeks ARO. A complete submittal and material delivery schedule will be developed and issued for review upon order entry.

Additional Notes on Clarifications or Addendum Page

SCOPE OF WORK: ADDITIONAL SERVICES

Please visit distransubstations.com for more information on each of the additional services listed below.

ITEM	SERVICE	CLARIFICATIONS
A1	<p>Standard Marshalling</p> <p><input checked="" type="checkbox"/> All minor materials (bus and grounding fittings, bolts, etc.) will be received, inspected, inventoried and shipped from our warehouse facility to the jobsite. All major materials (structures, equipment, pipe, cable, etc.) will be shipped direct from the manufacturer’s facility to the jobsite. Standard marshaling streamlines project execution by reducing material receiving tasks and reducing occurrence of product loss and damage.</p>	No clarifications
A2	<p>Full Marshalling</p> <p><input type="checkbox"/> All equipment and materials included in DIS-TRAN’s scope of supply will be received, inspected, inventoried and shipped from our warehouse facility to the jobsite, Full marshaling ensures all project materials arrive exactly when needed and in the sequence best suited to support project construction schedules.</p>	No clarifications
A3	<p>Shipping Containers</p> <p><input type="checkbox"/> Using secure, high quality containers, materials and equipment are delivered on-site fully inventoried, organized, labeled and ready for immediate, on-site use.</p>	No clarifications
A4	<p>Onsite Material Check-In Services</p> <p><input type="checkbox"/> Onsite Material Check-In Services include a thorough inspection of all materials for potential damage during transit and a comprehensive inventory of all materials to ensure correct quantities have arrived onsite.</p>	No clarifications
A5	<p>Field Advisory Services</p> <p><input type="checkbox"/> Seasoned personnel experienced in all aspects of the installation of high-voltage substation packages work closely with onsite contractors to ensure proper installation of the DIS-TRAN furnished structures, equipment and materials.</p>	No clarifications
A6	<p>Factory Built Substation</p> <p>DIS-TRAN FBS is a complete structural assembly, custom-constructed to exacting end-user specifications in a controlled manufacturing environment. It arrives fully assembled (to shipping limits) ready to be installed with minimal field labor and time. The drawing package will include lifting requirements and center of gravity locations. Structure off-loading and installation performed by others.</p> <p><input type="checkbox"/> Includes Conduit/Cable Tray with Secondary Wiring installed on FBS structure</p> <p><input type="checkbox"/> Includes above grade grounding installed on FBS structure</p> <p><input type="checkbox"/> Includes steel skids to support FBS structure</p>	No clarifications

What can you expect from DIS-TRAN drawings and documents?

DIS-TRAN prides itself on best-in-class project documents and drawings. We are an industry leader in integrating manufacturing and construction information via our CAD system, resulting in highly detailed informative drawings that provide all the information you need to install your station. For more information, please visit distransubstations.com.

MATERIAL DELIVERY

All checked items are included in this proposal. Contact us for more details on materials listed below but not included in our scope of supply.

ITEM	PRODUCT	CLARIFICATIONS	DELIVERY ARO/ARAD (WEEKS)	DELIVERY OPTIONS
D1	<input checked="" type="checkbox"/> Hot Dipped Galvanized Steel (Standard Shapes) Unassembled	See Technical Clarifications	37 weeks ARO	Factory Direct
D2	<input checked="" type="checkbox"/> Hot Dipped Galvanized Steel (Tapered Tubular) Unassembled	See Technical Clarifications	51 weeks ARO	Factory Direct
D3	<input checked="" type="checkbox"/> Anchor Bolts for Steel Structures	No clarifications	10 weeks ARAD	Factory Direct
D4	<input checked="" type="checkbox"/> Group Operated Switches Not Applicable	No clarifications	37 Weeks ARO	Factory Direct
D5	<input checked="" type="checkbox"/> Instrument Transformers	See Technical Clarifications	49 weeks ARO	Factory Direct
D6	<input checked="" type="checkbox"/> Arresters	See Technical Clarifications	44 weeks ARO	Marshalled
D7	<input checked="" type="checkbox"/> Capacitor Bank	See Technical Clarifications	46 weeks ARO	Factory Direct
D8	<input checked="" type="checkbox"/> Insulators	No clarifications	44 weeks ARO	Marshalled
D9	<input checked="" type="checkbox"/> Bus Material – Fittings & Hardware	No clarifications	44 weeks ARO	Marshalled
D10	<input checked="" type="checkbox"/> Bus Pipe	No clarifications	44 weeks ARO	Factory Direct
D11	<input checked="" type="checkbox"/> Above Grade Grounding	No clarifications	44 weeks ARO	Marshalled
D12	<input checked="" type="checkbox"/> Fuse Disconnect	No clarifications	44 Weeks ARO	Marshalled
D13	<input type="checkbox"/>	No clarifications	not applicable	TBD
D14	<input type="checkbox"/>	No clarifications	not applicable	TBD
D15	<input type="checkbox"/> See Additional Notes on Clarifications Page			

Clients say:

“My favorite benefit [of DTPS] is the detail of the drawings themselves. They have a lot of information on there that we can actually give to our contractor.”

SCOPE CLARIFICATIONS

DIS-TRAN's scope of work will be to provide JEA with Standard Shape/Tapered steel design & steel detailing, General Arrangement drawings with material lists & major equipment drawing. No additional engineering services provided in this quote.

DIS-TRAN will supply all steel structures inside of the 138/13.8kV Eagle Substation yard, along with bus work, switches, capacitor banks, arresters, insulators, combo metering units, potential transformers and above grade grounding material.

Materials not considered to be in DIS-TRAN's scope of work are station service transformers, lights, incoming-outgoing lines & associated fittings, below grade grounding, cable trench, control house, control cables, junction boxes/internal components, conduit, animal protection, main power transformer, oil containment materials & fencing material/fence grounding.

COMMERCIAL CLARIFICATIONS

All commercial terms per the JEA Alliance Agreement "JEA11286"

TECHNICAL CLARIFICATIONS

DIS-TRAN is assuming that the (2)bus supports shown before each 138kV A-Frame are not needed and the incoming cable can be routed to insulators located on the A-Frame.

Specified Ohio Brass part number 3140093001 has suggested alternate from Ohio Brass. DIS-TRAN is quoting Ohio Brass suggested alternate part number EVP0009003001.

DIS-TRAN is quoting high side jumpers as single run 954AAC per phase. & low side jumpers as (4) 1033.5 AAC per phase.

No tensions provided for steel. DIS-TRAN is using the below tensions for this proposal:

138kV A-Frame: 12.5k conductor & 2.5k static

138kV H-Frame: 5k conductor & 3k static

Probe Poles: 0k (no tension)

Arresters located by cap banks on single line diagram are not provided per email with Mir on 12/28/22.

750 KCMIL CU / XLPE Get away cable not provided in proposal.

No Spec provided for 13.8kV Combo metering units.

Capacitor Bank does not include any spare parts, testing or tooling.

SCHEDULE

Proposed Payment Schedule

MILESTONE	DESCRIPTION	DELIVERABLES	%
1	DIS-TRAN's procurement of long lead time items		20%
2	Submittal of design & manufacturing drawings for approval to include items	S1, S2, S3, S6, S7	40%
3	Delivery of structures, equipment and materials (multiple invoices possible, pending final delivery schedule) to include items	All Selected 'D' Items	40%
N/A			
N/A			

THANK YOU!

We appreciate you considering DIS-TRAN for your project! As you review this proposal, if you have any questions or would like to make any changes, please just let us know. Your direct contact is:



Laine Stoute
Proposal Coordinator
Laine.Stoute@distran.com
Direct: (318) 767.5621
Mobile: (318) 880.2580

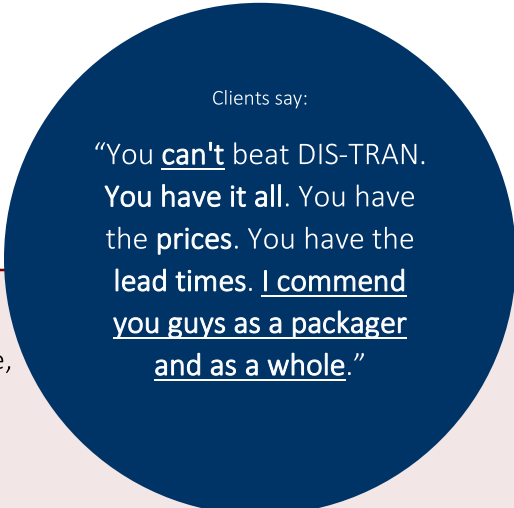

Clients say:

“You can't beat DIS-TRAN. You have it all. You have the prices. You have the lead times. I commend you guys as a packager and as a whole.”

Let DIS-TRAN power your success.

DIS-TRAN has been an industry leader in the design and supply of high-voltage, open-air substations and switchyards since 1965. We fuse exceptional technical expertise with fast, friendly service standards, so that every project can spark greater success and business results for you. Visit distransubstations.com for more information.

JEA Pricing Spreadsheet - Tier 2

Material Price Sheet for project greater than \$250k material cost

	Cost	Unit Mark Ups	Extended Prices
Steel Cost	\$ 779,522	30.0%	\$ 1,013,379
Equipment & Material Cost	\$ 1,209,187	30.0%	\$ 1,571,943
Subcontract Mark-Up		30.0%	\$ -
Total Material Amount	\$ 1,988,709		\$ 2,585,322

Items will be estimated at the beginning of every project.

Items will be trued up at the end of every project.

Multiple quotes will be obtained to determine best price and lead time.

Vendor invoices will be sent with customer invoices.

total.

For project totaling less than \$250k in material cost, mark up will be increase to 45%.

Services include: Steel Calculations, Steel Details, General Arrangement with Section View Drawings, Anchor Bolt Plan, Material List with catalog cut sheets.

Estimated Freight (PP&A)			\$ 43,000
-------------------------------------	--	--	------------------

Marshal/Vendor freight will be estimated and passed through to JEA

Freight invoices will be sent with customer invoices.

Contingency			\$ 198,870
--------------------	--	--	-------------------

10% of material cost

JEA to determine if needed or not. Delete if not needed

Total Contract Amount			\$ 2,827,192
------------------------------	--	--	---------------------

Pricing is valid for material and services scope listed above. Deviations to this scope may cause price adjustments.

Payment Milestones: Based off of Material and Services Sub Total Listed Above.

Milestone 1: 20% Procurement of Long Lead Time Material

Milestone 2: 40% Submittal of Calculations and Approval Drawings

Milestone 3: 40% Delivery

Milestone 3 percentage subject to change based off of final material cost after all drawings are approved



138/15kV Eagle Substation
Jacksonville Electric Authority
Jacksonville Electric Authority
FL

Origination Date: 12/19/2022
Proposal No: 104793

Item	Qty	UOM	Description	MFG	MFG Part Num	Unit Cost	Ext Cost
			138KV STRUCTURES				
1	2	EA	138KV A-FRAME DEADEND, CONDUCTOR PULL OF HT OF 60FT **REFERENCE DRAWING 5282-601**	DIS-TRAN	APPX WT = 30,000 LBS EA	\$118,800.00	\$237,600.00
2	2	EA	138KV H-FRAME DEADEND, 1 BAY, 55'-0" PULLOFF HEIGHT PROVISIONS FOR UNDERHUNG INSULATORS **REFERENCE DRAWING 9268-604**	DIS-TRAN	APPX WT = 19,423 LBS EA	\$64,434.00	\$128,868.00
3	10	EA	138KV SWITCH STAND, 3 PHASE, 21'-0" HIGH BUS **REFERENCE DRAWING 9268-608**	DIS-TRAN	APPX WT = 4,713 LBS EA	\$12,913.62	\$129,136.20
4	8	EA	138KV SWITCH STAND, 3 PHASE, 13'-0" BUS HEIGHT LOW BUS **REFERENCE DRAWING 9268-611**	DIS-TRAN	APPX WT = 2,825 LBS EA	\$7,740.50	\$61,924.00
5	7	EA	138KV BUS SUPPORT STAND, 3 PHASE, 13'-0" BUS HEIGHT **REFERENCE DRAWING 9268-610**	DIS-TRAN	APPX WT = 1,229 LBS EA	\$3,367.46	\$23,572.22
6	2	EA	138KV BUS SUPPORT STAND, 3 PHASE, 21'-0" BUS HEIGHT **REFERENCE DRAWING 9268-613**	DIS-TRAN	APPX WT = 1,739 LBS EA	\$4,764.86	\$9,529.72
7	1	EA	138KV 1Ø HIGH BUS SUPPORT, 21'-0" BUS HEIGHT	DIS-TRAN	APPX WT = 550 LBS EA	\$1,507.00	\$1,507.00
8	6	EA	138KV ANGLED BUS SUPPORT STAND, 3 PHASE, 13'-0" BUS HEIGHT **REFERENCE DRAWING 9268-614**	DIS-TRAN	APPX WT = 1,560 LBS EA	\$4,274.40	\$25,646.40
9	10	EA	138KV POTENTIAL TRANSFORMER STAND, SINGLE PHASE, **REFERENCE DRAWING 9268-612**	DIS-TRAN	APPX WT = 518 LBS EA	\$1,419.32	\$14,193.20
10	2	EA	138KV 1Ø LOW BUS SUPPORT, BUS HEIGHT 13' 0"	DIS-TRAN	APPX WT = 500 LBS EA	\$1,370.00	\$2,740.00
11	8	EA	PROBE POLES (PP1 - PP8) LIGHTING ATTACHMENT 30FT FROM GRADE **DIRECT EMBED** **PER DRAWING 5651-E08**	DIS-TRAN	APPX WT = 3,016 LBS EA	\$12,198.00	\$97,584.00
12	6	EA	15KV 1Ø PT STAND PROVISIONS FOR: FUSED DISCONNECTS	DIS-TRAN	APPX WT = 600 LBS EA	\$1,644.00	\$9,864.00
13	2	EA	15KV 3Ø FUSED DISCONNECT & PT SUPPORT STAND, 15FT BUS HEIGHT **REFERENCE DRAWING 9267-604**	DIS-TRAN	APPX WT = 950 LBS EA	\$2,603.00	\$5,206.00



138/15kV Eagle Substation
 Jacksonville Electric Authority
 Jacksonville Electric Authority
 FL

Origination Date: 12/19/2022
 Proposal No: 104793

14	2	EA	15KV TERMINATOR STRUCTURE, 3 PHASE, 18'-0" BUS HEIGHT WITH PROVISIONS FOR 3 ARRESTERS BELOW GRADE TERMINATION **REFERENCE DRAWING 9268-618**	DIS-TRAN	APPX WT = 1,160 LBS EA	\$3,178.40	\$6,356.80
15	2	EA	15KV SINGLE BAY BREAKER STRUCTURE, 18FT BUS HEIGHT PROVISIONS FOR: INSULATORS & SWITCHES **REFERENCE DRAWING 9267-601**	DIS-TRAN	APPX WT = 1,603 LBS EA	\$4,392.22	\$8,784.44
16	2	EA	15KV BUS SUPPORT STAND, 18'-0" BUS HEIGHT **REFERENCE DRAWING 9268-615**	DIS-TRAN	APPX WT = 1,204 LBS EA	\$3,298.96	\$6,597.92
17	2	EA	15KV 3Ø CT STAND	DIS-TRAN	APPX WT = 950 LBS EA	\$2,603.00	\$5,206.00
18	2	EA	15KV 3Ø BUS SUPPORT PROVISIONS FOR: SSVT & FUSED DISCONNECT **REFERENCE DRAWING 9267-608**	DIS-TRAN	APPX WT = 950 LBS EA	\$2,603.00	\$5,206.00
20	21	EA	GROUND PLATFORM 3' X 4'	DIS-TRAN		\$350.00	\$7,350.00
			MAJOR EQUIPMENT				
ME1	18	EA	138KV, 2000A, 650KV BIL, 100KA MOM GROUP OPERATED VERTICAL BREAK SWITCH, WORM GEAR OPERATED CLEVELAND PRICE : V2-CA SOUTHERN STATES - WAG	Southern States, LLC	EV-2-145-2000	\$21,088.00	\$379,584.00



138/15kV Eagle Substation
Jacksonville Electric Authority
Jacksonville Electric Authority
FL

Origination Date: 12/19/2022
Proposal No: 104793

ME2	16	EA	138KV CAPACITOR VOLTAGE TRANSFORMER Type:Outdoor,Oil-FilledCapacitiveVoltageTransformer CarrierAccessories:Without Max.Sys.Voltage: 145kV Nom.Sys.Voltage: 138kV Nom.Frequency: 60Hz BIL:650kVp Altitude:1000masl(3300fasl) PFWV: 320kV RatedPrim.Voltage: 80500V Ratio: 700/1200:1:1 Accuracy/Burden: XandYWinding1.2WXYZ ZWinding: N/A Capacitance:6250pF OvervoltageFactor: 1.2cont.1.5/30s ThermalBurden: 1000VA CreepageDistance: 4650(183.07)mm(in) InsulatorType:Composite Color: Grey ComplianceStandard: ANSIC93.1-1999	GE	JYOTCF145	\$7,350.00	\$117,600.00
ME3	6	EA	138KV SURGE ARRESTER, 108KV DUTY CYCLE, 84KV MCOV ABB: Q108SA084D COOPER: UHAA108084A6045A11 GE: 9L11XPA108AS HUBBELL: EVP0084003001	Cooper Power Systems	UHAA108084A6045A11	\$1,460.14	\$8,760.84
ME4	2	EA	15KV, 4000 AMP, 110KV BIL, 61KA MOM, 3 PHASE, GROUP OPERATED, ALUMINUM VERTICAL BREAK SWITCH, COMPLETE WITH: A. TR-205 STATION POST INSULATORS, GRAY B. MANUAL SWING HANDLE OPERATOR C. STANDARD ARCHING HORNS	Southern States, LLC	EV-2H-15.5-4000	\$21,188.00	\$42,376.00
ME5	6	EA	13.8KV POTENTIAL TRANSFORMER, SINGLE PRIMARY BUSHING, DRY TYPE, 150KV BIL, 14,400 PRIMARY VOLTAGE, VOLTAGE RATIO OF120:1, 0.3% W, X, Y, Z, AND ZZ BURDENS ABB 7526A63G02 Ritz 122031010.395685	Ritz Instrument Transformer	122031010.395685 (VEF25-10)	\$2,414.00	\$14,484.00
ME6	6	EA	13.8kv COMBO METERING UNIT, 4000A, CT ACCURACY CLASS 0.3, AND PT RATIO 10:1 **PLACEHOLDER**	ITEC	**PLACEHOLDER**	\$15,000.00	\$90,000.00
ME7	12	EA	KILOVOLTS: 25 AMPERES: 400 KV BIL: 150 SMD-40 STATION -VERTICAL OUTDOOR DISTRIBUTION POWER FUSE MOUNTING	S&C Electric Co., Inc.	192323-SP-Z5	\$2,075.00	\$24,900.00
ME8	10	EA	KILOVOLTS: 25 AMPERES: 1 SPEED: 115-2 SMU-40 POWER FUSE UNIT	S&C Electric Co., Inc.	823001	\$505.00	\$5,050.00



138/15kV Eagle Substation
Jacksonville Electric Authority
Jacksonville Electric Authority
FL

Origination Date: 12/19/2022
Proposal No: 104793

ME9	2	EA	KILOVOLTS: 25 AMPERES: 10 SPEED: 153-2 (E) SMU-40 POWER FUSE UNIT	S&C Electric Co., Inc.	823010	\$505.00	\$1,010.00
ME11	6	EA	13.2KV CLASS; 10KV DUTY CYCLE; 8.4KV MCOV	Cooper Power Systems	UHAA010008A1045A11	\$323.94	\$1,943.64
ME12	54	EA	TR288, STATION POST INSULATOR, STANDARD STRENGTH, 138KV, 650KV BIL	Newell Porcelain	SK-47802-7001	\$255.00	\$13,770.00
ME13	30	EA	TR205, STATION POST INSULATOR, STANDARD STRENGTH, 15KV, 110KV BIL	Newell Porcelain	ST-231002-7001	\$30.00	\$900.00
ME14	6	EA	DEAD END POLYMER INSULATOR	Maclean	S248089VA07	\$320.42	\$1,922.52
ME15	2	EA	Outdoor, open-air, substation, fuseless, shunt capacitor bank rated 46.4 Mvar @ 145 kV-LL (42.0 Mvar @ 138 kV-LL), 650 kV-BIL, 60Hz, three phase, connected ungrounded single wye. Each phase will consist of 4 parallel strings with 6 series connected capacitors per string. One shunt capacitor bank will consist of the following equipment: 9 – Capacitor block frames (racks), welded marine grade aluminum. The capacitors will be factory installed horizontally into the block frames. The block frame mounting centers are 44" x 36". 72 – Capacitors, 644 kvar, 13,953 volt, 125 kV-BIL, 2 bushings (22" creepage), 60 Hz, Edisol VI non-PCB dielectric fluid, Heavy Duty (HD) type p/n: CEP17042A1. 3 – Capacitor bank elevating structures, welded marine grade aluminum, 9.0 feet high. 12 – Base insulators, porcelain, station post type, 650 kV-BIL. 24 – Stacking insulators, porcelain, station post type, 250 kV-BIL. 1 – Potential transformer, ITEC type VTO-650, oil-filled type, 138 kV, 650 kV-BIL, 80500 volt primary, 115 volt dual secondary, 700:1 & 700:1 ratio, 0.3WXYZ-ZZ accuracy, 6000 VA, p/n: VA106500700X000. Includes galvanized steel mounting stand. 1 – Lot of stainless steel hardware, bus work, bus insulators, intra-connection material, protective tubing for wire, and capacitor terminal birdguards. 1 – Touch-up paint, for capacitors, 12 oz. spray can, ANSI 70 gray, p/n CCM192B1.	Cooper Power Systems	CEB23004F0908F1	\$165,000.00	\$330,000.00
			BOLTS				
B1	1	LOT	TERMINAL BOLTS	Threaded Fasteners, Inc.		\$7,450.60	\$7,450.60



B2	1	EA	EQUIPMENT MOUNTING BOLTS	Threaded Fasteners, Inc.		\$2,200.00	\$2,200.00
B3	1	LOT	ANCHOR BOLTS FOR STANDARD SHAPE STEEL STRUCTURES (292) 1" x 2' 6" ANCHOR BOLT W/ 2HHN & 2FW (FOR STANDARED SHAPE STRUCTURES) (73) SETTING TEMPLATES FOR STEEL STRUCTURES	Threaded Fasteners, Inc.		\$11,800.00	\$11,800.00
B4	1	LOT	ANCHOR BOLTS FOR TAPERED STEEL	Dis-Tran Steel LLC		\$30,702.90	\$30,702.90
BUS & CONDUCTOR							
BC1	1320	EA	4" SCH 40, BUS PIPE, 6063-T6, 40FT LENGTHS	TW Metals Inc.		\$15.75	\$20,790.00
BC2	520	EA	6" SCH 40 BUS PIPE, 6063-T6, 40FT LENGTHS	TW Metals Inc.		\$28.65	\$14,898.00
BC3	440	EA	3" SCH 40 BUS PIPE, 6063-T6, 40FT LENGTHS	TW Metals Inc.		\$11.33	\$4,985.20
BC4	225	EA	4/0 AAC "OXLIP"	Champion Wire	"OXLIP"	\$0.92	\$207.00
BC5	520	EA	266.8 ACSR "WAXWING" FOR DAMPING	Champion Wire	"WAXWING"	\$1.38	\$717.60
BC6	1320	EA	556.5 ACSR "PARAKEET" FOR DAMPING	Champion Wire	"PARAKEET"	\$2.68	\$3,537.60
BC7	2200	EA	954 AAC, 37STR, "MAGNOLIA"	Champion Wire	"MAGNOLIA"	\$4.61	\$10,142.00
BC8	800	EA	1033.5 AAC "BLUEBELL"	Champion Wire	"BLUEBELL"	\$3.39	\$2,712.00
BC9	2100	EA	7#5 COPPERWELD CABLE	Champion Wire		\$4.99	\$10,479.00
BC10	1	EA	BUS BAR 1/2" X 4" X 20'	Aluminum & Stainless		\$304.33	\$304.33
STATIC PROTECTION							
SP1	300	EA	3/8" E.H.S STATIC WIRE	Champion Wire		\$0.82	\$246.00
SP2	4	EA	QUADRANT STRAIN CLAMP	Hubbell Power Systems, Inc.	SWDE46N	\$65.29	\$261.16
SP3	4	EA	ANCHOR SHACKLE	Hubbell Power Systems, Inc.	AS25BNK	\$16.89	\$67.56
SP4	25	EA	PARALLEL GROVE CONNECTOR, 3/8" E.H.S TO 7#5 COPPERWELD CABLE	Hubbell Power Systems, Inc.	LC811AXB	\$5.77	\$144.25
HIGH SIDE BUS MATERIAL							
HS1	46	EA	WELDED, TERMINAL, 4" SCH 40 BUS PIPE TO 4-HP, CENTERFORMED	Sefcor, Inc.	WFTC-64-4A	\$56.57	\$2,602.22
HS2	24	EA	WELDED, EXPANSION TERMINAL, 4" SCH 40 BUS PIPE TO 4-HP, CENTERFORMED	Sefcor, Inc.	WFXTC-V-64-4B	\$182.82	\$4,387.68
HS3	48	EA	BUS SUPPORT, 4" SCH 40 BUS PIPE TO 5" BOLT CIRCLE	Sefcor, Inc.	ASWH-64-5-SE	\$55.39	\$2,658.72
HS4	26	EA	END BELL, 4" IPS, WELDED	Sefcor, Inc.	WEB-64	\$13.09	\$340.34



138/15kV Eagle Substation
Jacksonville Electric Authority
Jacksonville Electric Authority
FL

Origination Date: 12/19/2022
Proposal No: 104793

HS5	18	EA	WELDED, TEE, 4" SCH 40 BUS PIPE TO 4-HP	Sefcor, Inc.	WTF-64-4B	\$39.43	\$709.74
HS6	6	EA	COUPLER, 4" SCH 40 BUS PIPE TO 4" SCH 40 BUS PIPE	Sefcor, Inc.	WSC-6464	\$86.24	\$517.44
HS7	36	EA	WELDED, TEE, 15°, 4" SCH 40 MAIN TO (1) 3" SCH 40 TAP	Sefcor, Inc.	WFTT15-6462	\$48.66	\$1,751.76
HS8	18	EA	WELDED, VEE CONNECTOR, 4" SCH 40 MAIN TO (2) 3" SCH 40 TAPS, 15°	Sefcor, Inc.	WFVT15-6462	\$75.48	\$1,358.64
HS9	36	EA	WELDED, TEE, 15°, 3" SCH 40 MAIN TO 3" SCH 40 TAP	Sefcor, Inc.	WFTT15-6262	\$41.70	\$1,501.20
HS10	57	EA	WELDED, TERMINAL, (2) 954 AAC 37STR TO 4-HP	Sefcor, Inc.	WFC2-34-4B	\$60.92	\$3,472.44
HS11	44	EA	WELDED, TERMINAL, (1) 954 AAC 37STR TO 4-HP	Sefcor, Inc.	WFC-34-4B	\$29.50	\$1,298.00
HS12	54	EA	WELDED, TERMINAL, 90° (2) 954 AAC 37 STR TO 4-HP	Sefcor, Inc.	WFC2-90-34-4B	\$60.92	\$3,289.68
HS13	6	EA	CABLE BUS SUPPORT, (2) 954 AAC 37STR TO 5" BOLT CIRCLE	Sefcor, Inc.	AVCA2-34-5	\$64.52	\$387.12
HS14	80	EA	CABLE SPACER, 954 AAC 37STR, 4" SPACING	Sefcor, Inc.	ASPC-34-4	\$30.17	\$2,413.60
HS15	6	EA	DEADEND COMPRESSION ASSEMBLY, 954 AAC, SINGLE TONGUE	Hubbell Power Systems, Inc.	C011212NT	\$219.39	\$1,316.34
HS16	6	EA	SOCKET Y-CLEVIS	Hubbell Power Systems, Inc.	SYC30	\$36.59	\$219.54
HS17	6	EA	CABLE TEE, 954 AAC 37STR TO 4-HP	Sefcor, Inc.	ACF-34-4A	\$44.06	\$264.36
HS18	6	EA	Y-CLEVIS TO BALL	Hubbell Power Systems, Inc.	YBC30	\$21.46	\$128.76
HS19	9	EA	GROUNDING STUD FOR 4" SCH 40 BUS PIPE	Sefcor, Inc.	WTS-6064	\$13.80	\$124.20
			LOW SIDE BUS MATERIAL				
LS1	12	EA	DUAL WELDED TERMINAL, 45° (2) 1033.5 AAC TO 4-HP	Sefcor, Inc.		\$85.72	\$1,028.64
LS2	12	EA	DUAL WELDED TERMINAL, (2) 1033.5 AAC TO 4-HP	Sefcor, Inc.		\$60.88	\$730.56
LS4	18	EA	WELDED, TERMINAL, 6" SCH 40 BUS PIPE TO 4-HP, CENTERFORMED	Sefcor, Inc.	WFTC-69-4B	\$119.95	\$2,159.10
LS5	6	EA	WELDED, EXPANSION TERMINAL, 6" SCH 40 BUS PIPE TO 4-HP, CENTERFORMED	Sefcor, Inc.	WFXTC-V-69-4B	\$364.51	\$2,187.06
LS6	30	EA	BUS SUPPORT, 6" SCH 40 BUS PIPE TO 3" BOLT CIRCLE	Sefcor, Inc.	ASWH-69-3-SE	\$69.07	\$2,072.10
LS7	18	EA	WELDED, TERMINAL, 6" SCH 40 BUS PIPE TO 4-HP	Sefcor, Inc.	WFT-69-4B	\$140.78	\$2,534.04
LS8	6	EA	END CAP, 6" SCH 40 BUS PIPE, DRIVE TYPE	Sefcor, Inc.	DP-69-AL	\$43.16	\$258.96
LS9	18	EA	WELDED, TERMINAL, 4/0 AAC TO 4-HP	Sefcor, Inc.	WFC-11-4A	\$20.56	\$370.08
LS10	6	EA	GROUNDING STUD, 6" SCH 40 BUS PIPE	Sefcor, Inc.	WTS-6064	\$13.80	\$82.80



138/15kV Eagle Substation
 Jacksonville Electric Authority
 Jacksonville Electric Authority
 FL

Origination Date: 12/19/2022
 Proposal No: 104793

LS11	28	EA	WELDED, TERMINAL, 4/0 AAC TO 2-HP	Sefcor, Inc.	WFC-11-2B	\$12.69	\$355.32
LS12	18	EA	CABLE SPACE FOR 1033.5 AAC, 6" SPACING	Sefcor, Inc.	ASPC-39-4	\$38.50	\$693.00
			GROUNDING MATERIAL				
G1	18	EA	BRONZE TAP LUG, CABLE TO FLAT	H-J Enterprises, Inc.	BTLS25-001TP	\$25.00	\$450.00
G2	21	EA	TERMINAL, 7#5 COPPERWELD TO 2-HP	Sefcor, Inc.	FNCT-20H-2B	\$46.90	\$984.90
G3	190	EA	GROUND CLAMP, 2 PIECE 1 CONDUCTOR, 7#5 COPPERWELD, W/ GALVANIZED HARDWARE, TINNED	Sefcor, Inc.	GTC-14-SND	\$13.96	\$2,652.40
G4	115	EA	GROUND CLAMP, 2 PIECE 2 CONDUCTOR, 7#5 COPPERWELD, W/ GALVANIZED HARDWARE, TINNED	Sefcor, Inc.	GTC2-14-SND	\$18.15	\$2,087.25
G5	10	EA	GROUND CLAMP, 2" NPS OR 2-1/2" OD, #2-500 MCM	Sefcor, Inc.	GUR-5820	\$50.38	\$503.80
						TOTAL	\$1,988,709.89

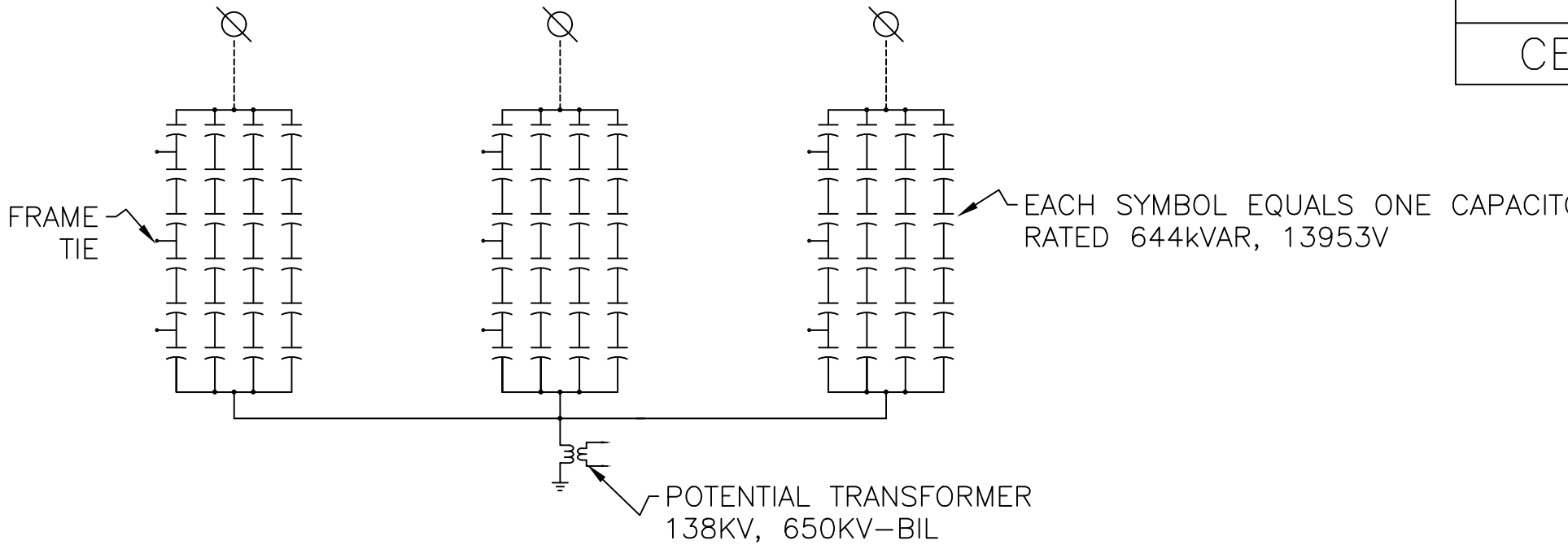

WIRING DIAGRAM

4-HOLE NEMA (ALUMINUM)
FOR CUSTOMER INCOMING
(250 AMPS MAX.)





MACLEAN POWER SYSTEMS

481 Munn Rd. Suite 300, Fort Mill, SC 29705 USA
 Phone: (803) 628-4300 Fax: (803) 396-8601

Catalog Number: **S248089VA07**
 Date: 11/15/2017

END FITTINGS / MATERIAL

Tower End Fitting: Y-Clevis
 Line End Fitting: Ball (ANSI 52-8/11)

Corona Ring (tower): none
 Corona Ring (line): 8" Corona Ring (Split)

Corona Rings are recommended for applications of 230 kV and above

Number of Sheds: 33
 Weight Estimate: 24.3 Lbs 11.1 kg

DIMENSIONAL VALUES

Section Length (A):	89 In	2,261 mm
Shed Diameter (B):	5.5 In	138 mm
Shed Spacing (C):	2.34 In	60 mm
Dry Arc Distance:	73.3 In	1,863 mm
Leakage Distance:	200.8 In	5,101 mm

ELECTRICAL VALUES

60 Hz Dry F.O.(Min. Withstand):	713 kV	(648 kV)
60 Hz Wet F.O.(Min. Withstand):	617 kV	(537 kV)
CIFO + (Min. Withstand):	1,193 kV	(1,058 kV)
CIFO - (Min. Withstand):	1,251 kV	(1,115 kV)

MECHANICAL VALUES

Specified Mech. Load (SML):	50,000 Lbs	222.4 kN
Routine Test Load (RTL):	25,000 Lbs	111.2 kN

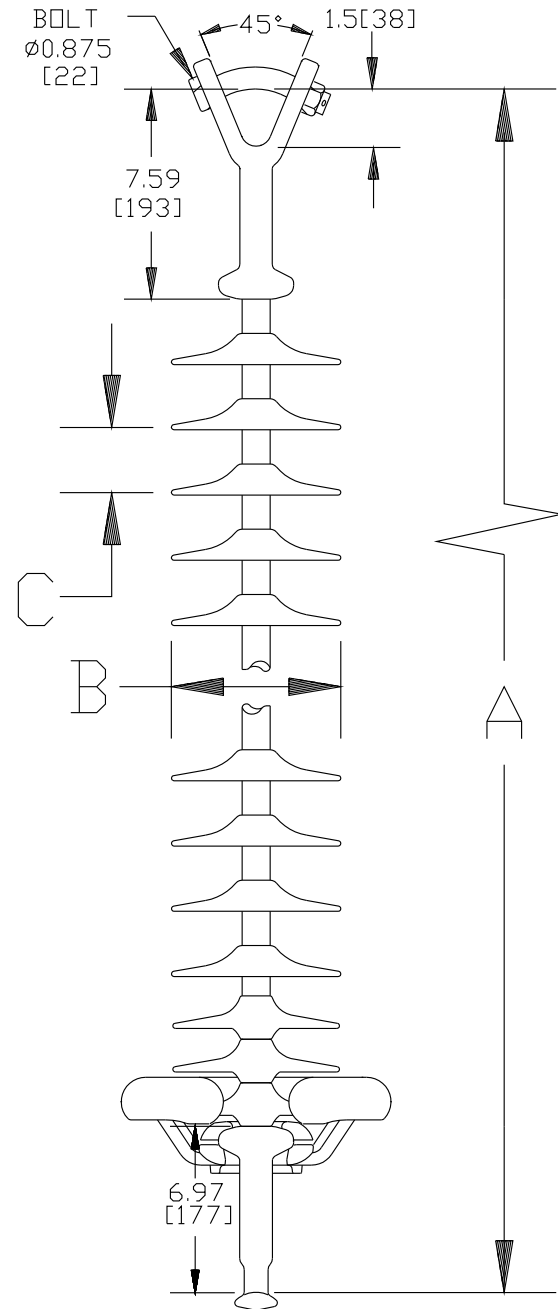

Approved	S24080089VA	0033	CNG

This drawing contains confidential information that is the property of MacLean Power L.L.C ("MacLean"). Use of MacLean's confidential information without MacLean's express written consent is strictly prohibited and may expose you to legal liability. If you believe that you received this material in error, please destroy it or return it to "MacLean Power, L.L.C., 481 Munn Rd, Suite 300, Ft Mill, SC 29715, USA."

Silicone Rubber Sheath & Sheds
 Complies with applicable ANSI and IEC standards.

LG-15-879

Outdoor station post current transformer



The LG-15-879 outdoor current transformer is designed for use on substation structures where bare tubular primary conductors or heavy braided cables are used.

Product features

- 15 kV class, 110 kV BIL, 60 Hertz
- Outdoor class, 105°C insulation system
- Single, dual, or multiple taps available
- Window opening: 4.5" (115 mm)
- Electrical specifications:
 - Strike: 12.5" (318 mm)
 - Creep: 24" (610 mm)
- Approximate weight (without bar):
 - Single core: 210 lbs. (96 kg)
 - Dual core: 270 lbs. (123 kg)
- Operating temperature range: -50°C through +65°C

Application

The LG-15-879 outdoor current transformer is designed for use on substation structures where bare tubular primary conductors or heavy braided cables are used. When provided with a factory installed primary bar assembly, it provides a pad terminal with a 4-hole NEMA bolt pattern on each end. For applications with an uninsulated bus (bar, tube, or cable), connect the pigtail lead to the bus to equalize the voltage in the window area for corona prevention. If a fully insulated bus (one that has an outer ground sheathing) is used, an equalizing potential connection is not required.

Mechanical description

The primary insulator is a cycloaliphatic epoxy (CEP) molded sleeve with a conductive inner lining to prevent corona. The CEP primary tube and the secondary winding are encapsulated in a polyurethane resin for outdoor use. An anodized aluminum nameplate is laser etched and adhered to the body of the unit, adjacent to the secondary junction box. Bright decals indicating the primary rated current are affixed to each side.

Terminals

The secondary terminals are 1/4"-20 UNC silicon bronze studs with associated hardware, suitable for solid or stranded copper wire up to No. 8 AWG, or ring tongue terminals sized for 1/4" or M7/M8 stud. Hardware is tightened to compress lock washers but not to exceed 50 in-lbF (5.6 N-m).

Primary bars are electro-tin plated, sized for the maximum rated continuous current (primary current x rating factor) and provided with standard NEMA 4-hole pads. Primary bars can also be sized for the rated current or lower; consult factory if desired. The LG-15-879 should not be used to support external bus work, but can support up to 200 pounds (91 kg) on the primary bar for connections. Primary bar kits may be purchased separately and installed in the field.

Mounting

The aluminum baseplate is 0.25" thick (6.4 mm) plain finish aluminum with 0.56" (14 mm) holes, suitable for mounting in the upright or underhung positions. It may also be mounted cantilever with the bus running vertically. In the case of cantilever mounting with bus running horizontally, there is a special baseplate ordering option that must be specified at the time of purchase. This is done by adding "-H" to the end of the style number.

Junction box

Secondary terminals are housed inside an injection molded thermoplastic junction box supplied with two (2) 1"-11.5 NPT hubs. Blank plugs are provided and must be replaced with proper fittings to maintain weathertight protection. A removable cover is attached with four (4) sealing-type thumb screws.

Test reports

Test reports are available and can be e-mailed upon request.

Standards

This unit meets or exceeds all requirements of IEEE C57.13-2016 and can be tested to other standards as requested.

Options

Animal guards are available to place around conductors and prevent entry of foreign objects or animals into the HV tube (ordered separately, the part number for a set of two animal guards for an LG with 4.5" window tube is 123-0098-901). The photos below show the guards separate and inside the window tube. For installation, cut out the center (thinner material) in the geometry and size needed for the conductor. Then slide the conductor through the guards and window tube. After the conductor is anchored in place, press the guard into the tube to seal around the primary conductor.

Optional primary bar kits for field installation available separately.

Consult factory for other special needs such as additional ratios, multiple cores with the same or mixed ratios, bars sized for lower current, bars rotated from horizontal to vertical position, extended bar lengths, bars with 6-hole pads instead of standard 4-hole, bars with thicker filler pads, etc. Requirements that can't be met in the LG-15-879 may be available in the KOTD-110 or LG-15-051 models.

—
01 Optional LG animal guard prior to installation.
—

02 Animal guard pressed in the window tube of the LG. To install, cut out the center of the guard for the primary conductor pass-through.



—
01

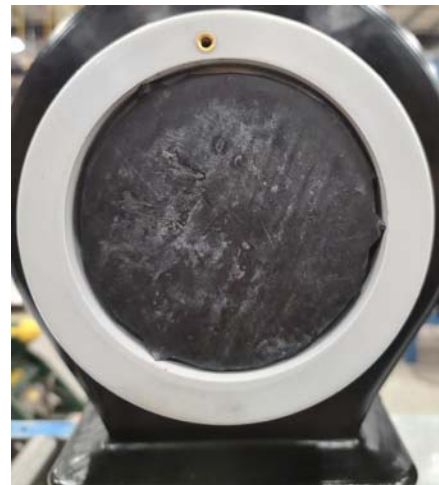

—
02

Dimensions (inches [mm])

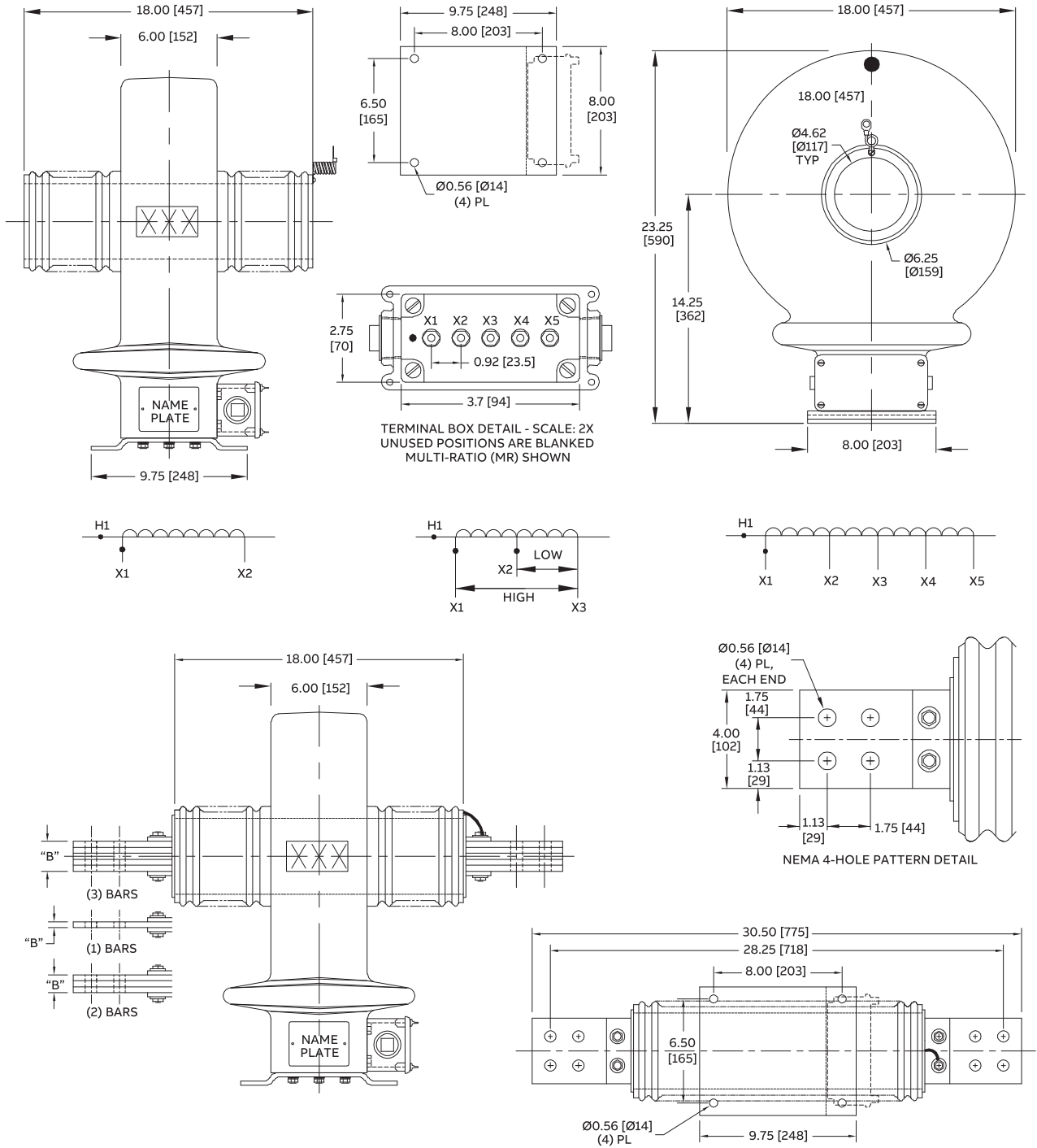

Primary bar information

Max. amps 75°C rise	Stack thickness dim. "B"	(No. bars) bar thickness	Bar assembly weight (lbs. [kg])
1200 A	0.25 [6.4]	(1) 1/4"	16 [7.3]
1800 A	0.38 [9.5]	(1) 3/8"	21 [9.5]
2500 A	0.75 [19]	(2) 1/4"	29 [13.2]
3500 A	1.00 [25]	(2) 3/8"	41 [18.6]
6000 A	1.63 [41]	(3) 3/8"	61 [27.7]

Primary bars are selected based on the maximum amps of the primary rated current times the rating factor.

Selection guide for LG-15-879 with 5A secondary

Primary current rating	Rating factor @ 30° C	IEEE metering accuracy @ 60 Hz	IEEE relaying accuracy @ 60 Hz	Style number		Primary bar kit (for field installation)
				Window-type	Bar-type	
200	3.0	0.3B-0.2	C150	D092015S159-1	D092015S159-3	424 0126 901
300	3.0	0.3B-0.5	C200	D093015S209-1	D093015S209-3	424 0126 901
400	3.0	0.3B-0.9	C300	D094015S309-1	D094015S309-3	424 0126 901
500	3.0	0.3B-1.8	C400	D095015S409-1	D095015S409-3	424 0127 901
600	3.0	0.3B-1.8	C400	D096015S409-1	D096015S409-3	424 0127 901
800	2.0	0.3B-1.8	C600	D098015S609-1	D098015S609-3	424 0127 901
1000	2.0	0.3B-1.8	C800	D091025S809-1	D091025S809-3	424 0126 902
1200	2.0	0.3B-1.8	C800	D091225S809-1	D091225S809-3	424 0126 902
1500	2.0	0.3B-1.8	C800	D091525S809-1	D091525S809-3	424 0127 902
2000	2.0	0.3B-1.8	C800	D092025S809-1	D092025S809-3	424 0127 903
2500	2.0	0.3B-1.8	C800	D092525S809-1	D092525S809-3	424 0127 903
3000	2.0	0.3B-1.8	C800	D093025S809-1	D093025S809-3	424 0127 903
4000	1.5	0.3B-1.8	C800	D094025S809-1	D094025S809-3	424 0127 903
5000	1.5/1.2 ¹	0.3B-1.8	C800	D095025S809-1	D095025S809-3	424 0127 903
6000	1.5/1.0 ¹	0.3B-1.8	C800	D096025S809-1	D096025S809-3	424 0127 903
8000	1.25	0.3B-1.8	C800	D098025S809-1	-	-
10000	1.0	0.3B-1.8	C800	D091035S809-1	-	-
Dual-ratio						
200/400	2.0/2.0	0.3B-0.2/B-0.9	C150/C300	D092015D159-1	D092015D159-3	424 0126 901
300/600	2.0/2.0	0.3B-0.5/B-1.8	C200/C400	D093015D209-1	D093015D209-3	424 0126 901
400/800	2.0/2.0	0.3B-0.9/B-1.8	C300/C600	D094015D309-1	D094015D309-3	424 0127 901
500/1000	2.0/2.0	0.3B-0.9/B-1.8	C400/C800	D095015D409-1	D095015D409-3	424 0126 902
600/1200	2.0/2.0	0.3B-1.8/B-1.8	C400/C800	D096015D409-1	D096015D409-3	424 0126 902
1000/2000	2.0/2.0	0.3B-1.8/B-1.8	C400/C800	D091025D409-1	D091025D409-3	424 0127 903
1500/3000	2.0/2.0	0.3B-1.8/B-1.8	C800	D091525D809-1	D091525D809-3	424 0127 903
2000/4000	2.0/1.5	0.3B-1.8/B-1.8	C400	D092025D409-1	D092025D409-3	424 0127 903
Multi-ratio						
400 MR	2.0	0.3B-0.5 ²	C300	D094015M309-1	D094015M309-3	424 0126 901
600 MR	2.0	0.3B-1.8 ²	C400	D096016M409-1	D096016M409-3	424 0126 901
1200 MR	2.0	0.3B-1.8 ²	C800	D091225M809-1	D091225M809-3	424 0126 902
2000 MR	2.0	0.3B-1.8 ²	C800	D092025M809-1	D092025M809-3	424 0127 903
3000 MR	2.0	0.3B-1.8 ²	C800	D093025M809-1	D093025M809-3	424 0127 903
4000 MR	1.5	0.3B-1.8 ²	C800	D094025M809-1	D094025M809-3	424 0127 903
5000 MR	1.5/1.2 ¹	0.3B-1.8 ²	C800	D095025M809-1	D095025M809-3	424 0127 903

1 - Reduced rating factor when supplied with ABB primary bar kits

2 - Metering class accuracy applies to full winding ratio only

One second ratings: thermal I_{th} – 85 times nominal, second/mechanical I_{mech} – 220 times nominal first peak

Additional styles available upon request. Contact your ABB sales representative or call +1-252-827-3212 for more information.



Formal Bid and Award System

Award #4 March 2, 2023

Type of Award Request: CHANGE ORDER
Requestor Name: Clendening, William M.
Requestor Phone: (904) 665-4723
Project Title: Buckman Biosolids Conversion Projects
Index Number: 711-26
Project Location: JEA
Funds: Capital
Business Unit Estimate: \$1,200,000.00

Scope of Work:

The Buckman Water Reclamation Facility (WRF) treats an average of 30 million gallons per day (MGD) of wastewater and processes waste activated sludge and primary sludge produced from eight (8) other JEA treatment plants. This award will secure professional design and engineering services for multiple projects, including treatment and infrastructure improvements, at Buckman. The goal is to manage all proposed projects under one Consultant to provide clear oversight, better alignment of schedules and shorten project timelines. These capital improvements will result in Buckman having the necessary facilities and processes in place to produce biosolids to be utilized for beneficial purposes for the next 20+ years.

JEA IFB/RFP/State/City/GSA#: 127-17
Purchasing Agent: Kruck, Dan
Is this a Ratification?: NO

RECOMMENDED AWARDEE(S):

Name	Contact Name	Email	Address	Phone	Amount
CAROLLO ENGINEERS INC.	Sudhan Paranjape	sparanjape@carollo.com	1089 West Morse Blvd, Suite A Winter Park, FL 32789	(407) 478-4642	\$1,086,707.24

Amount of Original Award: \$5,679,431.64
Date of Original Award: 07/19/2018
Change Order Amount: \$1,086,707.24

List of Previous Change Order/Amendments:

CPA #	Amount	Date	Reason
175699	(\$333,197.00)	04/21/2020	Contract reduction due to reducing scope and changing to lump sum to reduce administrative costs
175699	\$653,483.00	08/24/2020	Increase for JEA requested design changes
175699	\$60,212.00	10/21/2020	Increase to perform inspections of the structural systems of the existing Sludge Disposal Building
175699	\$7,053,403.28	04/22/2021	Design of a new drum drying process for dewatered biosolids and the redesign of the existing thickening and dewatering buildings to house the complete processes under one roof

175699	\$209,989.00	10/14/2021	Screen alternatives for struvite control/mitigation alternatives, and evaluate side-stream treatment alternatives for nitrogen removal
175699	\$989,893.30	04/07/2022	Added design and SDC for the rehabilitation of the biosolids processing facility
175699	\$52,646.00	07/12/2022	Added design and SDC for new perimeter sidewalks outside the fence of the Buckman WRF due to COJ permitting requirements
175699	\$46,883.00	08/25/2022	Re-design of HVAC system to an air-cooled chilled water system due to JEA directed changes

New Not-To-Exceed Amount: \$15,499,451.46
Length of Contract/PO Term: Project Completion
Begin Date: 8/14/2018
End Date: Project Completion (Expected: January 2028)
JSEB Requirement: Twenty Percent (20%) Evaluation Criteria

Comments on JSEB Requirements:

Original Award

GM Hill Engineering Inc - Structural & Mechanical/Electrical/Plumbing (MEP) Services: 7.0%
C&ES Consultants - Construction Inspection & Architectural Services: 27.2%
BV Group & Associates Inc - Site Survey/Subsurface Utility Engineering (SUE): 0.6%
Meskel & Associates - Geotechnical: 1.2%

Previous Amendment

CE&S Consultants Inc. (Construction Inspection) – 13.9%
B&V Associates (Site Survey/SUE) – 0.03%
Meskel & Associates Inc. (Geotechnical) – 0.09%

Previous Amendment

C&ES Consultants Inc. (Architectural Services) – 5.66%

This Amendment

Meskel & Associates Inc. (Geotechnical) – 1.6%

Background/Recommendations:

Originally approved by Awards Committee on 07/19/2018, in the amount of \$5,679,431.64 to Carollo Engineers Inc. Multiple amendments have been approved and are summarized on the table above. A copy of the previously approved award documents are attached for reference.

The design for the Raw Sludge Holding Tank (RSHT) at the 60% stage was based on reusing the existing RSHT. At the 60% design review meeting JEA decided it was necessary to demolish the existing tank and construct a new RSHT due to the age and condition of the existing RSHT. The new RSHT will be built at a different location at the plant due to potential settlement issues at the current location which cannot be studied until the demolition of the existing RSHT is complete. Relocating the new RSHT will provide Buckman WRF better options for biosolids treatment now and in the future while conserving space required for future facilities. JEA also decided to alter the current flow of sludge from Arlington East and the District II WRFs directly into the new RSHT, which will make the thickening process easier to operate. The thirteen design/re-design items listed below are included in this amendment request to incorporate these updates.

1. New 2.0 MG Raw Sludge Holding Tank (RSHT)
2. Odor control system for the new RSHT
3. Compressed gas mixing system for the new RSHT
4. New raw sludge screening
5. New sludge thickening system feed pumps and piping

6. New electrical building to serve the new RSHT, sludge screening, thickener feed pumps, odor control system and RSHT mixing system
7. New District II Sludge on-site pump station and associated influent and discharge piping
8. Revisions to site/civil/stormwater and yard piping changes associated with the new RSHT
9. Dryer heat recovery system
10. Addition of 125 kW emergency generator for dewatering process
11. Revisions to the polymer system
12. Addition of nitrogen generators for using nitrogen gas for bulk pellet product transport
13. Demolition of the old chlorine building

The fee for this work was based on previously negotiated hourly rates. The scope and fee are attached for reference.

Request approval to award a change order to Carollo Engineers Inc. for additional design/engineering for the Buckman Biosolids Conversion Projects in the amount of \$1,086,707.24, for a new not-to-exceed amount of \$15,499,451.46, subject to the availability of lawfully appropriated funds.

Manager: Phillips, Brian R. – Mgr. W/WW Project Management
Senior Manager: Doherty, Peter F. – Senior Manager Project Management
Director: Conner, Sean M. – Dir. W/WW Project Engineering & Construction
VP: Melendez, Pedro A. – VP Planning Engineering & Construction

APPROVALS:

Chairman, Awards Committee	Date
-----------------------------------	-------------

Budget Representative	Date
------------------------------	-------------



Formal Bid and Award System

Award #5 April 7, 2022

Type of Award Request: CONTRACT AMENDMENT
Requestor Name: Clendening, William M.
Requestor Phone: (904) 665-4723
Project Title: Buckman Biosolids Conversion Projects
Project Number: 8007764
Project Location: JEA
Funds: Capital
Budget Estimate: \$1,000,000.00

Scope of Work:

The Buckman Water Reclamation Facility (WRF) treats an average of 30 million gallons per day (MGD) of wastewater and processes waste activated sludge and primary sludge produced from eight (8) other JEA treatment plants. This award will secure professional design and engineering services for multiple projects, including treatment and infrastructure improvements, at Buckman. The goal is to manage all proposed projects under one Consultant to provide clear oversight, better alignment of schedules and shorten project timelines. These capital improvements will result in Buckman having the necessary facilities and processes in place to produce biosolids to be utilized for beneficial purposes for the next 20+ years.

JEA IFB/RFP/State/City/GSA#: 127-17
Purchasing Agent: Kruck, Dan
Is this a Ratification?: NO

RECOMMENDED AWARDEE(S):

Name	Contact Name	Email	Address	Phone	Amount
CAROLLO ENGINEERS INC.	Sudhan Paranjape	sparanjape@carollo.com	1089 West Morse Blvd, Suite A Winter Park, FL 32789	(407) 478-4642	\$989,893.30

Amount of Original Award: \$5,679,431.64
Date of Original Award: 07/19/2018
Change Order Amount: \$989,893.30

List of Previous Change Order/Amendments:

CPA #	Amount	Date	Reason
175699	(\$333,197.00)	04/21/2020	Contract reduction due to reducing scope and changing to lump sum to reduce administrative costs.
175699	\$653,483.00	08/24/2020	Increase for JEA requested design changes.
175699	\$60,212.00	10/21/2020	Increase to perform inspections of the structural systems of the existing Sludge Disposal Building.
175699	\$7,053,403.28	04/22/2021	Design of a new drum drying process for dewatered biosolids and the redesign of the existing thickening and dewatering buildings to house the complete processes under one roof.

175699	\$209,989.00	10/14/2021	Screen alternatives for struvite control/mitigation alternatives, and evaluate side-stream treatment alternatives for nitrogen removal.
--------	--------------	------------	---

New Not-To-Exceed Amount: \$14,313,215.22
Length of Contract/PO Term: Project Completion
Begin Date: 4/27/2018
End Date: Project Completion (Expected: May 2026)
JSEB Requirement: Twenty Percent (20%) Evaluation Criteria

Comments on JSEB Requirements:

Original Award

GM Hill Engineering Inc - Structural & Mechanical/Electrical/Plumbing (MEP) Services: 7.0%
C&ES Consultants - Construction Inspection & Architectural Services: 27.2%
BV Group & Associates Inc - Site Survey/Subsurface Utility Engineering (SUE): 0.6%
Meskel & Associates - Geotechnical: 1.2%

Previous Amendment

CE&S Consultants Inc. (Construction Inspection) – 13.9%
B&V Associates (Site Survey/SUE) – 0.03%
Meskel & Associates Inc. (Geotechnical) – 0.09%

This Contract Amendment

C&ES Consultants Inc (Architectural Services) – 5.66%

Background/Recommendations:

Originally approved by Awards Committee on 07/19/2018 in the amount of \$5,679,431.64 to Carollo Engineers Inc. On 04/21/2020, an administrative decrease was issued to reduce scope and change the contract to a lump sum format. On 08/24/2020, JEA issued an administrative increase for design changes requested by JEA including relocation of the new sludge thickening building and odor control, design of new concrete block building, re-design for compliance with updated resiliency plan, design of barrier concrete wall on south side of plant, and assistance with public outreach. On 10/21/2020, JEA issued an administrative increase to perform inspections of the structural systems of the existing sludge disposal building. On 04/22/2021, the Awards Committee approved a contract increase for a design of a new drum drying process. On 10/14/2021, an administrative increase was approved to study alternatives for struvite control and nitrogen removal. A copy of the previously approved award documents are attached for reference.

The biosolids processing facility is comprised of a large multi-story building constructed back in the early 1970s. The building houses all of the biosolids thickening, dewatering, thermal drying and ancillary support equipment including all electrical gear, instrumentation and controls. The building is composed of structural steel beams and column braced frames.

Due to its age and the corrosive environment, the building is in relatively poor condition. Carollo Engineers Inc. performed a preliminary structural, architectural, and electrical condition assessment of the building and its components. The condition assessment report provided a roadmap of high to low priority of items that will need to be either repaired or replaced to extend the life of the building while providing a safe working environment for the operations staff, support the equipment and related biosolids treatment processes for the next 7 to 10 years.

This contract amendment will provide the necessary design documents and services during construction for the rehabilitation of the biosolids processing facility. The construction portion of the work will be managed by JEA's Construction Manager at Risk (CMAR) Wharton-Smith. The fee for this work was based on previously negotiated hourly rates. The fee table is attached for reference.

Request approval to award a contract amendment to Carollo Engineers Inc. for additional design/engineering for the Buckman Biosolids Conversion Projects in the amount of \$989,893.30, for a new not-to-exceed amount of \$14,313,215.22, subject to the availability of lawfully appropriated funds.

Manager: Phillips, Brian R. - Mgr W/WW Project Management

Director: Conner, Sean M. - Dir W/WW Project Engineering & Construction

VP: Vu, Hai X. - VP Water Wastewater Systems

APPROVALS:

Stephen Datz 4/7/22

Chairman, Awards Committee **Date**

Laure A Whitmer 4/7/22

Budget Representative **Date**



Formal Bid and Award System

Award #6 April 22, 2021

Type of Award Request: CONTRACT AMENDMENT
Requestor Name: Clending, William
Requestor Phone: (904) 665-4723
Project Title: Buckman Biosolids Conversion Projects
Project Number: 8004764/8004765/711-54
Project Location: JEA
Funds: Capital
Budget Estimate: \$9,235,457.72

Scope of Work:

The Buckman Water Reclamation Facility (WRF) treats an average of 30 million gallons per day (MGD) of wastewater and processes waste activated sludge and primary sludge produced from eight (8) other JEA treatment plants. This award will secure professional design and engineering services for multiple projects, including treatment and infrastructure improvements, at Buckman. The goal is to manage all proposed projects under one Consultant to provide clear oversight, better alignment of schedules and shorten project timelines. These capital improvements will result in Buckman having the necessary facilities and processes in place to produce biosolids to be utilized for beneficial purposes for the next 20+ years.

JEA IFB/RFP/State/City/GSA#: 127-17
Purchasing Agent: Kruck, Dan
Is this a Ratification?: NO

RECOMMENDED AWARDEE(S):

Name	Contact Name	Email	Address	Phone	Amount
CAROLLO ENGINEERS INC.	Sudhan Paranjape	sparanjape@carollo.com	1089 West Morse Blvd, Suite A Winter Park, FL 32789	(407) 478-4642	\$7,053,403.28

Amount of Original Award: \$5,679,431.64
Date of Original Award: 07/19/2018
Change Order Amount: \$7,053,403.28

List of Previous Change Order/Amendments:

CPA #	Amount	Date	Reason
175699	(\$333,197.00)	04/21/2020	Contract reduction due to reducing scope and changing to lump sum to reduce administrative costs.
175699	\$653,483.00	08/24/2020	Increase for JEA requested design changes.
175699	\$60,212.00	10/21/2020	Increase to perform inspections of the structural systems of the existing Sludge Disposal Building.

New Not-To-Exceed Amount: \$13,113,332.92
Length of Contract/PO Term: Project Completion
Begin Date: 4/27/2018

End Date: Project Completion (Expected: May 2026)

JSEB Requirement: Twenty Percent (20%) Evaluation Criteria

Comments on JSEB Requirements:

Original Award

GM Hill Engineering Inc - Structural & Mechanical/Electrical/Plumbing (MEP) Services: 7.0%*
C&ES Consultants - Construction Inspection & Architectural Services: 27.2%
BV Group& Associates Inc - Site Survey/Subsurface Utility Engineering (SUE): 0.6%
Meskel & Associates - Geotechnical: 1.2%

This Amendment Request

CE&S Consultants Inc. (Construction Inspection) – 13.9%
B&V Associates (Site Survey/SUE) – 0.03%
Meskel & Associates Inc. (Geotechnical) – 0.09%

*Note: GM Hill is no longer JSEB Certified

Background/Recommendations:

Originally approved by Awards Committee on 07/19/2018 in the amount of \$5,679,431.64 to Carollo Engineers Inc. A copy of the original award is attached as backup. On 04/21/2020, an administrative decrease was issued to reduce scope and change the contract to a lump sum format. On 08/24/2020, JEA issued an administrative increase for design changes requested by JEA including relocation of the new sludge thickening building and odor control, design of new concrete block building, re-design for compliance with updated resiliency plan, design of barrier concrete wall on south side of plant, and assistance with public outreach. On 10/21/2020, JEA issued an administrative increase to perform inspections of the structural systems of the existing sludge disposal building.

This award request is for an increase to the design contract of Carollo Engineers Inc. for the Buckman Biosolids Conversion Projects due to JEA’s decision to update design of the future biosolids process at the Buckman WRF, as a result of canceling the Merchant Organics Recycling Facility (MORF) project. The design updates include the design of a new drum drying process for dewatered biosolids and the redesign of the existing thickening and dewatering buildings to house the complete processes under one roof. It should be noted that updating the drum drying process was one of the options in the original solicitation scope of work that the prospective engineering firms were evaluated on in the past performance sections. The fee for this work was based on previously negotiated hourly rates, and is approximately 23.6% lower than estimated. Carollo has gained knowledge of the biosolids process the Buckman WRF over the course of this contract, and is the reason for the fee coming in below estimate. The quote is attached as backup.

Request approval to award a contract amendment to Carollo Engineers Inc. for additional design/engineering for the Buckman Biosolids Conversion Projects in the amount of \$7,053,403.28, for a new not-to-exceed amount of \$13,113,332.92, subject to the availability of lawfully appropriated funds.

Manager: Collier, Bradley W. - Mgr W/WW Project Management

Director: Conner, Sean M. - Dir W/WW Project Engineering & Construction

VP: Vu, Hai X. - VP Water Wastewater Systems

APPROVALS:

 _____ 04/22/2021

Chairman, Awards Committee **Date**

 _____ 4/23/21

Budget Representative **Date**



Formal Bid and Award System

CPA 175699

Award #10 July 19, 2018

Type of Award Request: PROPOSAL (RFP)
Request #: 3982
Requestor Name: Collier, Bradley W. – Mgr WW Plants & Pump Stations
Requestor Phone: (904) 665-6493
Project Title: Buckman Biosolids Conversion Projects
Project Number: 8004764/8004765/8004766
Project Location: JEA
Funds: Capital
Award Estimate: \$5,869,000.00

Scope of Work:

The Buckman Water Reclamation Facility (WRF) treats an average of 30 million gallons per day (MGD) of wastewater and processes waste activated sludge and primary sludge produced from eight (8) other JEA treatment plants. This award will secure professional design and engineering services for multiple projects, including treatment and infrastructure improvements, at Buckman. The goal is to manage all proposed projects under one Consultant to provide clear oversight, better alignment of schedules and shorten project timelines.

The following is a list of the projects:

1. Addition of a post aerobic digestion process for biosolids
2. Addition of a new biosolids processing facility
3. Addition of generator capacity/gas conditioning facility
4. Demolition of the existing biosolids process building
5. Expansion of the vacuum truck unloading facility
6. New electrical and instrumentation (E&I) building
7. New operations and maintenance (O&M) building
8. New pump maintenance building
9. Addition of raw sludge tank and improvements to existing tank
10. Addition of fiber communication

These capital improvements will result in Buckman having the necessary facilities and processes in place to produce biosolids to be utilized for beneficial purposes for the next 20+ years.

JEA IFB/RFP/State/City/GSA#: 127-17

Purchasing Agent: Kruck, Daniel Robert (Dan)

Is this a Ratification?: NO

RECOMMENDED AWARDEE(S):

Name	Contact Name	Email	Address	Phone	Amount
CAROLLO ENGINEERS INC.	Dwayne Kreidler	dKreidler@carollo.com	1089 West Morse Blvd, Suite A, Winterpark, FL 32789	(407) 478-4642	\$5,679,431.64

Amount for entire term of Contract/PO: \$5,679,431.64
Award Amount for remainder of this FY: \$262,000.00
Length of Contract/PO Term: Project Completion
Begin Date (mm/dd/yyyy): 07/30/2018
End Date (mm/dd/yyyy): Project Completion (Expected: 07/2023)
JSEB Requirement: Optional - Twenty Percent (20%) Goal

Comments on JSEB Requirements:

GM Hill Engineering Inc - Structural & Mechanical/Electrical/Plumbing (MEP) Services: 7.0%
 C&ES Consultants - Construction Inspection & Architectural Services: 27.2%
 BV Group & Associates Inc - Site Survey/Subsurface Utility Engineering (SUE): 0.6%
 Meskel & Associates - Geotechnical: 1.2%
 Total: 36%

BIDDERS:

Name	Amount	Rank
CAROLLO ENGINEERS INC.	\$5,679,431.64	1
CH2M HILL ENGINEERS INC.	N/A	2
BROWN AND CALDWELL	N/A	3

Background/Recommendations:

Advertised on 08/18/2017. Six (6) companies attended the pre-proposal meeting held on 08/24/2017. At Proposal opening on 09/19/2017, JEA received three (3) Proposals. The public evaluation meeting was held on 01/31/2018, and JEA deemed Carollo Engineers, Inc. most qualified to perform the work. A copy of the evaluation matrix and negotiated schedule fees are attached as backup.

Negotiations with Carollo Engineers Inc. were successfully completed. The proposed engineering fee of \$5,679,431.64 is 3.2% lower than estimated and deemed reasonable. Compared to estimated construction costs of \$45,801,868.06, the proposed design fee is 12.4% of construction.

127-17 - Request approval to award a contract to Carollo Engineers, Inc. for design and services during construction of the Buckman Biosolids Conversion project in the amount of \$5,679,431.64, subject to the availability of lawfully appropriated funds.

Director: Marshall, Raynetta C. - Dir, WWW Grid Project Eng & Construction
VP: Calhoun, Deryle I. - VP/GM Water Wastewater Systems

APPROVALS:

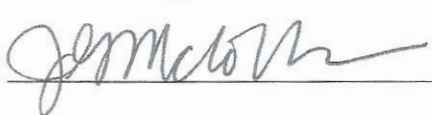
7/19/18

Chairman, Awards Committee Date

7/19/18

Manager, Capital Budget Planning Date

JEA
Buckman Biosolids Conversion Capital Project components
Solicitation Number 127-17, P.O. 189658

Change Order No. 9

RAW SLUDGE HOLDING TANK AND OTHER DESIGN CHANGES

As part of this Change Order No. 9, Carollo Engineers, Inc. (ENGINEER) will provide professional engineering services for revising the design of the following biosolids treatment system components as part of the Buckman Biosolids Capital Conversion Projects (BBCCP):

1. New 2.0 MG Raw Sludge Holding Tank (RSHT)
2. Odor control system for the new RSHT
3. Compressed gas mixing system for the new RSHT
4. New raw sludge screening
5. New sludge thickening system feed pumps and piping
6. New electrical building to serve the new RSHT, sludge screening, thickener feed pumps, odor control system and RSHT mixing system
7. New District II Sludge on-site pump station and associated influent and discharge piping
8. Revisions to site/civil/stormwater and yard piping changes associated with the new RSHT
9. Dryer heat recovery system
10. Addition of 125 kW emergency generator for dewatering process
11. Revisions to the polymer system
12. Addition of nitrogen generators for using nitrogen gas for bulk pellet product transport
13. Demolition of the old chlorine building

BACKGROUND

As part of the on-going BBCCP, the 60% design was based on reusing the existing RSHT with scope of work encompassing emptying out the contents of the tank, installing a well-point dewatering system to allow draining of the tank, structural inspection followed by necessary repairs, replacing the aluminum dome cover, replacing the odor control system, and adding a

new compressed gas mixing system. The three existing GBT feed pumps were to be replaced with three new GBT feed pumps with new piping to the new biosolids processing facility.

Given the age of the RSHT (60+ years old, constructed in 1959), the condition of the tank interior which is anticipated to be deteriorated due to exposure to high levels of corrosive hydrogen sulfide and other reduced sulfur compounds, and a significant dead volume that exists due to the fact that the tank conical bottom extends 14-feet below the prevailing seasonal ground water table, at 60% design completion it was agreed to potentially demolish the existing tank and construct a new RSHT that would address the above deficiencies in the same location.

During the 60% design review meeting, JEA also agreed to revise the design to divert a major portion of existing satellite sludge (sludge pumped from Arlington East and District II WRFs) currently mixed with the raw wastewater from the Buckman service area, directly to the new RSHT. This will substantially reduce the loading on the existing primary clarifiers provide a homogenous loading on the sludge thickeners that would make the thickening process easier to operate and potentially retain some of the organics that could increase gas production in the digesters.

Subsequently, after completion of necessary geotechnical investigations, no firm recommendations could be made to construct a new RSHT in the same location without the risk of differential settlement. The existing RSHT is constructed on piles and the condition of these piles cannot be determined at this time.

After the geotechnical findings, JEA opted to construct the new RSHT at a new location close to the proposed and currently under design new biosolids handling facilities. Constructing the new RSHT at this location will reduce the overall risk and construction time while reducing the pumping distance to the new thickening facilities. The existing RSHT will continue to serve the existing biosolids handling facilities until the new RSHT is constructed. In the future, the existing RSHT could be demolished, and a destructive pile integrity test could be conducted to confirm the reuse of the existing piles, and a fourth digester could be constructed in the same location. Overall, relocating the new RSHT will provide Buckman WRF better options for biosolids treatment now and in the future while conserving space required for future facilities.

The ENGINEER prepared a technical memorandum for sizing of the new RSHT and also prepared conceptual layout of the new RSHT and associated facilities that was approved by JEA for final design.

In addition, post 60% design, several other biosolids handling process improvements were agreed to in an effort to enhance the overall reliability, redundancy and safety of the new biosolids handling facilities. These improvements will be incorporated into the design of the on-going BBCCP as listed above and described in detail below.

SCOPE OF SERVICES

The professional services required to deliver this alternatives evaluation will comprise the tasks described below.

Task 1.1 – Update the Basis of Design Report (30% Submittal)

The draft Basis of Design Report (BODR) that was prepared and submitted in March 2022 will be updated to document the revisions to the overall scope of the BBCCP as described above and establish the revised design criteria. The updated FINAL BODR can be used by maintenance and operations personnel for operation, recommissioning, and maintenance. The revised BODR will complement the documents to be used for applying for the construction and operating permits from Florida Department of Environmental Protection (FDEP).

Task 1.2 – Update to 60% Design Documents

New Raw Sludge Holding Tank (RSHT)

The 60% design drawings and specifications will be revised to include the design of a new 2.0 million gallon (MG) prestressed concrete RSHT with an aluminum dome cover, a new appropriately sized odor control system, and a new compressed gas mixing system.

The new RSHT will be located on the existing south-central pond area, just due east of the existing septage receiving station. The south-central pond will be relocated to the south of the existing Digester Control Building No. 2 and made bigger to compensate for the additional impervious areas associated with the new RSHT and several associated components. The tank floor will be constructed above the prevailing ground water table to allow complete emptying/draining of the tank and resulting in full capacity/volume utilization. Modifications will be made to the existing pavement around the south-central pond to accommodate access all around the new RSHT and its components while maintaining the access to the Digester Control Building No. 2 and the septage receiving station.

The design will include revisions and resizing of the odor control system and will comprise biotrickling filter technology providing a minimum of 20 seconds empty bed residence time (EBRT).

The design will also include revisions and resizing of the design of the compressed gas mixing system or the new RSHT.

Appropriate geotechnical investigations including up to 5 soil borings (SPTs) will be conducted to determine the foundation design for the new RSHT.

New Raw Sludge Screens

The new RSHT design will include pre-screening of raw sludge that will be stored in the new RSHT. This will reduce the deposition of unwanted debris and formation of rags within the RSHT. The existing RSHT is anticipated to have several feet of unwanted debris and rags at the bottom of the tank. Screening of sludge will also enhance the quality of the dried pellets.

JEA has invited two major screen manufacturers for a pilot test that will be conducted in the March/April 2023 timeframe. The goal of the test is to determine the efficacy of the screen equipment, throughput, pressure loss through the screen and other critical design parameters. Upon successful completion of the pilot test, the screen equipment design criteria will be established, and the number of duty and redundant screens will be determined. The screening structure will be an elevated concrete structure with the screen supported off an elevated platform with dumpsters located on grade for ease of removal and disposal/transport of the screenings.

Separately, new screens will also be designed for installation at the new cake receiving station for screening the diluted cake and the thickened sludge from Mandarin WRF.

The revised design will include plan views, sectional views and details for the screening structure, screening equipment, piping and other appurtenances.

Revisions to Thickening System Feed Pumps

The 60% design plans and specifications included replacing the three existing gravity belt thickener (GBT) feed pumps located in the basement of the existing Digester Control Building No. 1. With the relocation of the new RSHT, five new GBT feed pumps will be designed to feed to the new GBTs located in the new biosolids building. The design provides more reliability and redundancy for pumping the screened and mixed/homogenized sludge and for an even loading to the GBTs which should enhance and make the thickening operation more operator friendly. Based on the pilot test conducted by JEA using the Discflo pumps the revised design will be based on using Discflo pumps for pumping to the GBTs. The Discflo pumps have been historically used for pumping sludges with good success. This style of pumps offers less ragging and reduced maintenance and life cycle costs and are a good fit for this application.

Appropriately sized macerators or grinders will be designed on the suction side of the pumps to reduce the chances of rag build-up within the pump and discharge piping.

The revised design will include plan views, sectional views and details for the pumps, grinders, piping and other appurtenances.

New Electrical Building

A new appropriately sized climate controlled electrical building will be designed to support the electrical and controls needs for the new RSHT and several of the supporting components described above. The building will be constructed of CMU block with a modified membrane bituminous roof with architecture matching of that of the other buildings at Buckman WRF. The building will house the necessary motor control centers (MCC), control panels with programmable logic controllers (PLCs), lighting panels, air conditioning equipment and other necessary electrical and controls equipment. The building will be fed from the new switchgear(s) that are currently under design for the new biosolids building.

The revised design will include design of appropriate duct-banks and conduits for routing the power and fiber to various ancillary components around new RSHT.

New District II WRF Sludge On-site Pump Station

The ongoing design includes design of a new on-site pump station for receiving and pumping sludge from Arlington East WRF. The 60% plans and specifications included the design of this on-site pump station. However, with the relocation of the new RSHT to near the new biosolids facilities, this on-site pump station will no longer be required as the pumped sludge can be easily fed to the new RSHT through the screens. JEA is currently designing improvements to the sludge pump station at AE WRF which will include new pumps and also a redundant transfer pipe from AE WRF to Buckman WRF. Therefore, the new sludge pumps can be easily designed to accommodate any additional pressures to facilitate direct feeding into the new RSHT.

On the other hand, the sludge from District II WRF is pumped via a dedicated force main that intercepts the existing raw wastewater sewer/manhole just a few hundred feet upstream of the plant headworks on Buckman Street. Since this sludge flow need to be segregated and transferred to the new RSHT, the existing force main needs to be realigned and brought to the Buckman WRF to feed the new on-site pump station. From the on-site pump station, the sludge will be pumped directly to the new RSHT through the screens.

The design of the AE sludge pump station will be revised to receive and pump the sludge from District II WRF instead. The pump station will be relocated to a convenient location on the northwest parcel of the plant property and new piping will be designed to convey the sludge to the new RSHT.

Revisions to Site/Civil/Stormwater and Yard Piping

The relocation of the new RSHT and associated components will require revisions to the site plan, paving and grading plans, stormwater conveyance, design of a new south-central pond with sufficient capacity to compensate for the additional impervious area added with this change. The new south-central pond will be connected to the enlarged south-east pond with new conveyance structures to meet the FDEP's environmental resource permit (ERP) providing sufficient detention time and volume for water quality treatment and peak stormwater attenuation. The entire area west of the new biosolids building and east of the septage receiving station will be regraded and necessary stormwater conveyance will be designed to convey the stormwater to the new south-central pond and eventually to the south-east pond for discharge to the existing outlet structure.

Several yard piping additions and changes will be included in the design. The new RSHT and the pre-screening structure will be connected with new yard piping as described below at a minimum:

1. New piping from the existing primary clarifiers to convey the primary sludge and scum.

2. New piping from the existing secondary clarifiers to convey the waste activated sludge.
3. New piping from the new proposed on-site lift station to convey sludge from District II WRF.
4. Piping revisions to convey the sludge from AEWRF.
5. Overflow piping from the new RHST, potentially to the existing aeration basins.
6. Revisions to piping from the new GBT feed pumps to the new biosolids building.
7. Revisions to the piping from the new centrifuge feed pumps (located in the basement of the existing Digester Control Building No. 1) to the new biosolids building.
8. Revisions to the non-potable water piping for flushing needs at the new screening structure, at the odor control structure etc.
9. Revisions to the potable water piping for seal water needs for the new GBT feed pumps.

The revised design will include plan, profiles and other details for all of the process piping as described above.

Demolition of the Old Chlorine Building

ENGINEER prepared an ERP permit application that included a larger southeast pond in the southeast corner of the Buckman WRF site. This pond was designed to provide sufficient detention volume for both water quality treatment and peak flow attenuation for a 25-year, 24-hour storm. The pond bottom was assumed to match the existing pond bottom elevation at EL 4.0 ft NAVD 88. During review by the FDEP, it was found that the prevailing ground water table is around elevation 3.5 ft NAVD 88. Therefore, the pond bottom had to be raised to a higher elevation (~ 5.7 ft NAVD 88) to permit this as a “Dry Detention Pond” and allow for desired infiltration through the native soils. This requires an increase in the overall footprint of the pond. One option presented by ENGINEER and accepted by JEA is to demolish the Old Chlorine Building to add more surface area to the pond.

The revised design will include demolition drawings and details for demolition of this building.

Other Process Enhancements

Several process enhancements have been made to improve the reliability and redundancy and safety for ease of operations and maintenance as described below:

- **Dryer Heat Recovery System**

The condensate from the thermal drying process comprises of hot water with a temperature range of 150-deg F. A heat recovery system is currently in design to use this heat to pre-heat the thickened sludge before feeding into the digesters. Use of this waste heat will reduce the hot

water needs for heating the digester sludge and thereby reducing the stress on the existing boilers. The heat recovery system comprises heat pumps and spiral heat exchangers to pre-heat the thickened sludge as it feeds into the digesters. There will be one heat recovery pump that will pump the hot condensate to spiral heat exchangers that will be located on a concrete pad under a metal canopy just to the west of the proposed biosolids building. The thickened sludge pumps will pump the sludge through the heat exchanger to pre-heat the sludge.

- **Addition of a 125 Kw Emergency Generator with Fuel Tank**

Based on the review of the shop drawings prepared by Alfa-Laval for the new centrifuges, there became a need to provide emergency backup power to the cake conveyors to continue to convey the cake in complete loss of power. The Buckman WRF is currently fed power from dual sources. There is no emergency backup power at the facility as there is built-in redundancy with the dual power feeds. However, in the past there have been couple of instances when the plant has completely lost power for a short duration. The design of the new centrifuges is such that if there is complete loss of power, the centrifuge machine will enter a shut-down mode. In the shut-down mode, the machine will continue to spin down and empty all the cake on to the conveyors. However, in loss of power, the conveyors also need to remain operational for approximately 20 minutes to convey the cake to the wet-material bins until the centrifuge is empty and shuts down.. Therefore, a new 125-kW emergency generator is currently being designed to support this. This will require redesign to accommodate an automatic transfer switch (ATS) to feed the conveyor MCC line-up. The generator will be located on a concrete pad outside the new biosolids building to feed the ATS located in the electrical room on the second floor of the new biosolids building.

- **Nitrogen generators for use of nitrogen gas for bulk pellet transport and silo filling**

The manufacturer/supplier of the thermal drum drying equipment has recently made some innovations where they are using compressed nitrogen gas in lieu of compressed air for transport of the dried pellets and blanketing of the silo. Hot spots with the storage silo usually develop as the hot dried pellets sit within the silo. Use of the traditional compressed air poses the risk of fire hazard within the storage silos. Nitrogen, an inert gas, helps reduce the hot spots that are found inside the pellet silos and enhances the safety aspect of the design and operation.

The design will include addition of nitrogen generators. Nitrogen gas from the generators will be fed to the pellet transport system for use in the conveyance of the pellets to the silos.

- **Polymer System Revisions**

The on-going design includes bulk liquid polymer storage tanks, liquid polymer day tanks, polymer blending units where water will be mixed with the neat polymer followed by mixing and aging tanks. The polymer solution will be pumped using progressive cavity pumps to each of GBTs and centrifuges.

With the modern polymer production technology, many treatment plants are successfully using direct injection of blended polymer solution for thickening and dewatering operations. JEA is currently pilot testing direct injection of blended polymer solution from the polymer blending units straight into the centrifuges to see if there is any need for the mixing/aging tanks. If the results are positive, the design will be revised to eliminate the mixing/aging tanks and polymer solution pumps. Instead, the design will be revised to include appropriately sized polymer blending units to feed each of the 5 GBTs and 4 centrifuges (total of 9 PBUs plus standby units – one for each thickening and dewatering process). The need for a post-dilution valve will also be eliminated.

The design will include revised plans and specifications for the polymer blending units and associated feed piping.

Revised 60% Design Submittal (Task 1.2)

The revised 60% design submittal (plans and specifications) will include the new RSHT with revised mixing and odor control system, sludge screening structure, electrical building, new GBT feed pumps, paving, grading, stormwater conveyance, yard piping and other miscellaneous elements. A revised 60% cost estimate will be prepared and presented to JEA with the new RSHT improvements project.

Task 1.3 – Updated 90% Design Documents

Updated 90% Design Submittal (plans and specifications) will include the new RSHT, new sludge screens, new electrical building, dryer heat recovery system, 125 KW emergency generator, addition of nitrogen generators, revisions to the polymer system, demolition of the old chlorine building, and associated paving, grading, stormwater conveyance, yard piping and other miscellaneous elements

Task 1.4 – 100% Design Documents

100% Design Submittal (plans and specs) will include the above-described components.

Task 1.5 – Revisions to the ERP Permit

As described above, the ERP permit application will be appended with revised pervious and impervious area calculations, stormwater detention pond treatment volume calculations and all supporting reports and revised drawings as necessary. A face-to-face meeting will be schedule with FDEP at the earliest possible time to discuss the proposed changes including the addition of the new RSHT and associated components and the revisions made to the stormwater conveyance and treatment system. This will allow more coordination and assurance with the permitting agency to allow smoother and faster approval of the ERP permit.

Task 2.0 – Construction Phase Services

The following construction phase services are additional services (in addition to the services that have already been budgeted as part of the previous change orders) to be provided with the revisions to the RSHT Improvements project, in particular the addition of a new 2.0 mg tank, new sludge screens, new electrical building, and several modifications to the yard piping and stormwater conveyance.

Prepare Conformed Drawings

The ENGINEER will prepare conformed documents “Issued for Construction” by compiling bidder questions and addendums.

Attend Pre-construction Meeting

Since the RSHT Improvements project will be a separate project to be constructed with its own construction schedule, a separate pre-construction meeting is anticipated. The ENGINEER will attend one pre-construction meeting.

Review Shop Drawing Submittals

With the additional/revisions to several components of the RSHT Improvements project, additional shop drawings pertaining to the new sludge screens and structure, new electrical building and electrical gear such as MCC, panels etc., and new yard piping changes, up to 25 additional shop drawings are anticipated (RSHT tank, Tank dome, Sludge Screens and Controls, Screen Structure Piping and Valves, MCCs and Panels, Conduits and Wire, Electrical Building Doors and Windows, Electrical Building Foundation, Electrical Building Roof and gutters, Electrical Building Beams and Columns and CMU, GBT Feed Pump concrete pad, Stormwater Conveyance Piping and Structures, Yard Piping, Heat Recovery Heat Exchanger, Heat Recovery Pumps, 125 KW Emergency Generator and Fuel Tank, ATS etc.)

Review and Respond to Request for Information

The ENGINEER will receive, review, evaluate, and distribute Requests for Information (RFIs) from the CMAR. The ENGINEER shall respond to the CMAR to clarify or interpret technical or design related questions. The ENGINEER shall issue necessary interpretations and clarifications of the design documents.

Responses to RFIs are budgeted as 2 hours per RFI with addition of 10 additional RFIs.

Assist with Start-up, Testing and Training and amending plant O&M Manuals

The ENGINEER will lead and assist in the start-up, testing, and training services. Additionally, the ENGINEER will provide standard operating procedures (SOPs) for the new RSHT and sludge screening and update those portions of the O&M manual for the facility. The ENGINEER will add to the electronic O&M that will be prepared for the BBCCP project and components.

FEE

The method of payment for this project is lump sum. Total compensation for the services described in this CO#9 shall be **\$1,086,707.24**. Exhibit I provides a breakdown of the fee by task and labor.

SCHEDULE

This Scope of Services will be delivered inline with the overall schedule for the Buckman Biosolids Capital Conversion Projects and as depicted in Table 1 below.

Table 1:

Task	Design Timeline	Design Timeline
1.1	30% Design Document (Revised PDR)	Within 10 weeks from NTP
1.2	60% Design Documents (Revised Plans and Specs)	Within 24 weeks from NTP
1.3	90% Design Documents (Revised Plans and Specs)	Within 12 weeks from receipt of 60% design review comments from JEA/CMAR
1.4	100% Design Documents	Within 6 weeks from receipt of 90% design review comments from JEA/CMAR
1.5	Revisions to ERP Permit	Within 5 weeks from receipt of NTP

CAROLLO ENGINEERS INC. - Engineering Services Fee (EXHIBIT I)		Professional ES IV	Cost Estimation	Process Mech/Project Manager	Site/Civil & Stormwater Permitting	Electrical Engineer	Electrical CAD	Instrumentation & Controls Engineer	Instrumentation & Controls CAD	Architect	Structural Engineer	QA/QC (Overall)	Senior Designer	Document Processing/Graphics	Order Control	Total Hours	Total Labor Cost (Lump Sum)	Total Travel Costs (Mileage)	Printing
Revisions to RSHT Improvements and other components - Design Services	Buckman Biosolids Capital Conversion Projects																		
TASK	TASK DESCRIPTION	Loaded Rate	\$ 159.00	\$ 159.00	\$ 211.40	\$ 189.80	\$ 219.17	\$ 92.30	\$ 219.17	\$ 92.30	\$ 189.80	\$ 189.80	\$ 219.17	\$ 113.50	\$ 76.90	\$ 219.17			
1	DESIGN PHASE SERVICES																		
1.1	Update 30% Design (Revised Preliminary Design Report)	40	0	40	40	24	0	24	0	4	4	24	0	24	8	232	\$43,306		
1.2	Update 60% Design Documents	316	184	240	120	160	144	108	64	24	208	132	500	40	16	2256	\$367,245		
	New 2.0 MG RSHT	24	24	24	0	16	16	4	8	0	40	24	40	8	16		\$40,818		
	New Sludge Screens	160	40	120	0	40	24	80	40	0	80	24	120	8	0		\$124,055		
	Revisions to GBT feed pumping	60	32	24	0	40	24	24	16	0	24	24	120	8	0		\$61,471		
	New Electrical Building (for RSHT)	24	24	24	0	40	40	0	0	24	40	24	60	8	0		\$49,997		
	New District II WRF Sludge on-site PS and piping	24	24	24	0	24	40	0	0	0	24	12	40	8	0		\$33,998		
	Revisions to Site/Civil/Stormwater/Yard Piping	24	40	24	120	0	0	0	0	0	0	24	120	0	0		\$56,906		
	Demo of Old Chlorine Contact Building (See Note 1 below)	0	0	0	0	0	0	0	0	0	0	0	0	0	0		\$0		
	Dryer Heat Recovery System (See Note 1 below)	0	0	0	0	0	0	0	0	0	0	0	0	0	0		\$0		
	Addition of 125 kW Emergency Generator (See Note 1 below)	0	0	0	0	0	0	0	0	0	0	0	0	0	0		\$0		
	Revisions for addition of nitrogen generators (See Note 1 below)	0	0	0	0	0	0	0	0	0	0	0	0	0	0		\$0		
	Revisions to Polymer System (See Note 1 below)	0	0	0	0	0	0	0	0	0	0	0	0	0	0		\$0		
1.3	Update 90% Design Documents	352	0	232	44	304	224	152	112	16	236	208	448	40	8	2376	\$393,413		
	New 2.0 MG RSHT (See Note 2 below)	0	0	0	0	0	0	0	0	0	0	0	0	0	0		\$0		
	New Sludge Screens	100	0	40	0	80	40	24	16	0	120	40	120	8	0		\$98,096		
	Revisions to GBT feed pumping (See Note 2 below)	0	0	0	0	0	0	0	0	0	0	0	0	0	0		\$0		
	New Electrical Building	16	0	16	0	40	24	0	0	16	40	24	24	8	8		\$37,890		
	New District II WRF Sludge on-site PS and piping	24	0	24	0	24	40	0	0	0	24	12	40	8	0		\$30,182		
	Revisions to Site/Civil/Stormwater/Yard Piping	12	0	16	24	0	0	0	0	0	0	24	40	0	0		\$19,646		
	Demo of Old Chlorine Contact Building	24	0	24	0	0	0	0	0	0	12	12	24	0	0		\$16,521		
	Heat Recovery System	36	0	40	0	32	32	24	24	0	24	24	40	0	0		\$43,176		
	Addition of 125 kW Emergency Generator	60	0	40	0	64	40	32	24	0	40	24	60	0	0		\$64,606		
	Revisions for addition of nitrogen generators	40	0	16	20	40	24	40	24	0	24	24	60	8	0		\$48,188		
	Revisions to Polymer System	40	0	16	0	24	24	24	24	0	24	24	40	8	0		\$35,108		
1.4	100% Design Documents	100	0	116	0	88	80	40	40	8	42	66	116	24	8	728	\$120,272	\$0	
	New 2.0 MG RSHT (See Note 2 below)	0	0	0	0	0	0	0	0	0	0	0	0	0	0		\$0		
	New Sludge Screens	24	0	16	0	16	16	8	8	0	16	8	16	8	0		\$21,895		
	Revisions to GBT feed pumping (See Note 2 below)	0	0	0	0	0	0	0	0	0	0	0	0	0	0		\$0		
	New Electrical Building	8	0	16	0	16	16	0	0	8	8	8	16	8	8		\$18,613		
	New District II WRF Sludge on-site PS and piping	8	0	16	0	16	16	0	0	0	8	8	16	8	0		\$15,341		
	Revisions to Site/Civil/Stormwater/Yard Piping	8	0	16	0	0	0	0	0	0	8	8	16	0	0		\$8,224		
	Demo of Old Chlorine Contact Building	4	0	4	0	0	0	0	0	0	2	2	4	0	0		\$2,754		
	Heat Recovery System	8	0	16	0	8	8	8	8	0	8	8	8	0	0		\$12,299		
	Addition of 125 kW Emergency Generator	8	0	16	0	16	8	8	8	0	8	8	8	0	0		\$15,571		
	Revisions for addition of nitrogen generators	16	0	8	0	8	8	8	8	0	8	8	16	0	0		\$12,788		
	Revisions to Polymer System	16	0	8	0	8	8	8	8	0	8	8	16	0	0		\$12,788		
1.5	Revisions to ERP Permit	40	0	24	60	0	0	0	0	0	0	0	12	0	0	136	\$23,744		
2.0	CONSTRUCTION PHASE SERVICES	104	0	96	44	142	6	56	0	26	64	4	8	42	0	592	\$111,228		
	Prepare Conformed Documents	0	0	4	4	4	4	0	0	2	4	4	8	4	0				
	Attend Pre-Construction Meeting	0	0	8	2	2	2	0	0	0	2	0	0	0	0				
	Review Shop Drawing Submittals	60	0	50	30	120	0	40	0	24	40	0	25	0	0				
	Review and Respond to Request for Information	20	0	10	8	8	0	8	0	0	10	0	5	0	0				
	Assist with startup, testing and training and amend plant O&M Manuals	24	0	24	0	8	0	8	0	0	8	0	8	0	0				
	Subtotal Task	952	184	748	308	718	454	380	216	78	554	434	1,072	182	40	6,320	\$1,059,207	\$0	\$0
	Total Project Hours and Labor Costs	952	184	748	308	718	454	380	216	78	554	434	1,072	182	40	6,320	\$1,059,207	-	-
	Total Cost Per Labor Category	\$ 151,368.00	\$ 29,256.00	\$ 158,127.20	\$ 58,458.40	\$ 157,364.06	\$ 41,904.20	\$ 83,284.60	\$ 19,936.80	\$ 14,804.40	\$ 105,149.20	\$ 95,119.78	\$ 121,672.00	\$ 13,995.80	\$ 8,766.80	\$ -	\$1,059,207		
	Total Project Direct Expenses (Printing)																\$0.00		
	Total Travel Costs																\$0.00		
	TOTAL CAROLLO ENGINEERS INC.																\$1,059,207.24		
	SUBCONSULTANTS																		
	Geotechnical Subconsultant (Meskel & Associates Inc.)																\$17,500		
	Site Survey/SUE - Subconsultants (B. V. and Associates Inc.)																\$0		
	Construction Inspection and Architectural Services (CES Consultants Inc.)																\$0		
	Limited Structural and MEP Services (GM Hill Engineering Inc.)																\$10,000		
	SUBCONSULTANT SUBTOTAL																\$27,500.00		
	TOTAL LUMP SUM COSTS																\$1,086,707.24		

Notes:

- ENGINEER has already submitted 60% documents and all effort is included in the 90% design effort (see Task 1.3 below)
- Level of effort is already included in the previous authorization. Therefore costs are already budgeted and covered.



Formal Bid and Award System

Award #5 March 2, 2023

Type of Award Request: CONTRACT INCREASE
Requestor Name: Clendening, William
Requestor Phone: (904) 665-4723
Project Title: Construction Management-at-Risk (CMAR) Services for the Buckman Biosolids Conversion Projects
Project Number: 8004764
Project Location: JEA
Funds: Capital
Business Unit Estimate: \$15,000,000.00

Scope of Work:

The scope of work to be performed under this solicitation consists of CMAR services for the Buckman Biosolids Conversion Projects. This project is needed to update the treatment process at the Buckman Water reclamation Facility (WRF) to meet current and future needs. The projects to be constructed are listed below:

1. Biosolids Process Facility
2. Operations and Maintenance (O&M) Building
3. Ultraviolet (UV) Disinfection
4. Blower Improvements and Electrical Building

JEA IFB/RFP/State/City/GSA#: 086-19
CPA# 187261
Purchasing Agent: Kruck, Daniel R.
Is this a Ratification?: NO

RECOMMENDED AWARDEE(S):

Name	Contact Name	Email	Address	Phone	Amount
WHARTON-SMITH INC.	Nathan Hillard	nhillard@whartonsmith.com	PO Box 471028, Lake Monroe, FL 32747-1028	(407) 321- 8410	\$14,514,773.00

Amount of Original Award: \$971,322.00
Date of Original Award: 12/19/2019
Contract Increase Amount: \$14,514,773.00

List of Previous Change Order/Amendments:

CPA #	Amount	Date	Reason
187261	\$13,825,095.00	09/03/2020	Purchase and installation of the blower system improvements and site setup
187261	\$17,800,520.00	03/25/2021	Purchase and installation of the ultra-violet (UV) disinfection system
187261	\$14,397,053.00	3/24/2022	Site work and improvements, the purchase of an Alfa Laval Centrifuge unit, and Andritz Dryer support services.

187261	\$3,684,712.00	05/05/2022	Increase to remove existing fine screens, supply new JEA approved screens and appurtenances, and install influent channels
187261	\$175,699.27	06/10/2022	Additional pre-construction services requested by JEA for the dryer rehab and sludge holding tank projects

New Not-To-Exceed Amount: \$65,369,174.27
Length of Contract/PO Term: Project Completion
Begin Date: 01/06/2020
End Date: Project Completion (Expected: January 2028)
JSEB Requirement: Optional

Comments on JSEB Requirements:

Original Award

N/A

1st Contract Increase

ESB Security (Security) - 1.8%
Complete Coatings (Painting) - 0.85%

2nd Contract Increase

N/A – Specialty Equipment Purchase and Installation

3rd Contract Increase

JSEB Survey Allowance - \$30,020.00

4th Contract Increase

JSEB Survey Allowance - \$5,000.00

5th Contract Increase

N/A

This Contract Increase

Smith Surveying Group, LLC (Survey) - \$25,000.00 (Allowance)

Background/Recommendations:

Originally bid and approved by Awards Committee on 12/19/2019 in the amount of \$971,322.00 for pre-construction services to Wharton-Smith, Inc. Multiple amendments have been approved and are summarized on the table above. A copy of the previous awards are attached for reference.

This contract increase is to approve an early Guaranteed Maximum Price (GMP) for plant underground mechanical work, the purchase of gravity belt thickening equipment, bridge cranes purchase and elevator procurement. This early work package will allow the purchase of long lead items to keep the project on schedule and allow the contractor to perform necessary underground mechanical work to keep the biosolids facility construction on schedule.

JEA reviewed the CMAR GMP proposal and deemed the results reasonable when compared to past projects. A copy of the quote letter is attached for reference. As design progresses for the other aspects of the overall Buckman Biosolids Conversion Projects, additional GMPs will be brought before the Awards Committee. It is estimated that the overall contract value, inclusive of all projected projects, will be \$300,000,000.00.

Request approval to award a contract increase to Wharton-Smith, Inc. for equipment purchases and construction services as part of the Buckman Biosolids Conversion Projects in the amount of \$14,514,773.00, for a new not-to-exceed amount of \$65,369,134.27, subject to the availability of lawfully appropriated funds.

Manager: Phillips, Brian R. - Mgr Project Management
Senior Manager: Doherty, Peter F. – Senior Manager Project Management
Director: Conner, Sean M. - W/WW Project Engineering & Construction
VP: Melendez, Pedro A. – VP Planning Engineering & Construction

APPROVALS:

Chairman, Awards Committee	Date
-----------------------------------	-------------

Budget Representative	Date
------------------------------	-------------



Formal Bid and Award System

Award #11 May 5, 2022

Type of Award Request: CONTRACT INCREASE
Requestor Name: Clendening, William
Requestor Phone: (904) 665-4723
Project Title: Construction Management-at-Risk (CMAR) Services for the Buckman Biosolids Conversion Projects
Project Number: 711-49
Project Location: JEA
Funds: Capital
Budget Estimate: \$3,425,638.00

Scope of Work:

The scope of work to be performed under this solicitation consists of CMAR services for the Buckman Biosolids Conversion Projects. This project is needed to update the treatment process at the Buckman Water reclamation Facility (WRF) to meet current and future needs. The projects to be constructed are listed below:

1. Biosolids Process Facility
2. Operations and Maintenance (O&M) Building
3. Ultraviolet (UV) Disinfection
4. Blower Improvements and Electrical Building

JEA IFB/RFP/State/City/GSA#: 086-19
CPA# 187261
Purchasing Agent: Kruck, Daniel R.
Is this a Ratification?: NO

RECOMMENDED AWARDEE(S):

Name	Contact Name	Email	Address	Phone	Amount
WHARTON-SMITH INC.	Nathan Hillard	nhillard@whartonsmith.com	PO Box 471028, Lake Monroe, FL 32747-1028	(407) 321- 8410	\$3,684,712.00

Amount of Original Award: \$971,322.00
Date of Original Award: 12/19/2019
Contract Increase Amount: \$3,684,712.00

List of Previous Change Order/Amendments:

CPA #	Amount	Date	Reason
187261	\$13,825,095.00	09/03/2020	Purchase and installation of the blower system improvements and site setup
187261	\$17,800,520.00	03/25/2021	Purchase and installation of the ultra-violet (UV) disinfection system
187261	\$14,397,053.00	3/24/2022	Site work and improvements, the purchase of an Alfa Laval Centrifuge

			unit, and Andritz Dryer support services.
--	--	--	---

New Not-To-Exceed Amount: \$50,678,702.00
Length of Contract/PO Term: Project Completion
Begin Date: 01/06/2020
End Date: Project Completion (Expected: September 2024)
JSEB Requirement: Optional

Comments on JSEB Requirements:

Original Award

N/A

1st Contract Increase

ESB Security (Security) - 1.8%
Complete Coatings (Painting) - 0.85%

2nd Contract Increase

N/A – Specialty Equipment Purchase and Installation

3rd Contract Increase

JSEB Survey Allowance - \$30,020.00

This Contract Increase

JSEB Survey Allowance - \$5,000.00

Background/Recommendations:

Originally bid and approved by Awards Committee on 12/19/2019 in the amount of \$971,322.00 for pre-construction services to Wharton-Smith, Inc. A contract increase in the amount of \$13,825,095.00 was approved by the Awards Committee on 09/03/2020 for the purchase and installation of the blower system improvements. A contract increase in the amount of \$17,800,520.00 was approved by the Awards Committee on 03/25/2021, for the purchase and installation of the ultra-violet disinfection system. A contract increase was approved by the Awards Committee on 03/24/2022 in the amount of \$14,397,053.00 for site improvements and the purchase of a centrifuge unit and dryer support. A copy of the previous awards are attached as backup.

This contract increase is to remove existing fine screens, supply new JEA approved screens and appurtenances, and install influent channels.

The negotiated price of this work package of \$3,684,712.00 is approximately 7.6% above the estimate for this work. The primary reason for the over-estimated price is the inclusion of \$259,075.00 in JEA directed allowances. The allowances are only used with the approval of the JEA project manager. JEA reviewed the CMAR GMP proposal and deemed the results reasonable when compared to past projects. A copy of the quote letter is attached as backup. As design progresses for the other aspects of the overall Buckman Biosolids Conversion Projects, additional GMPs will be brought before the Awards Committee. It is estimated that the overall contract value, inclusive of all projected projects, will be \$300,000,000.00.

Request approval to award a contract increase to Wharton-Smith, Inc. for the fine screen work package as part of the Buckman Biosolids Conversion Projects in the amount of \$3,684,712.00, for a new not-to-exceed amount of \$50,678,702.00, subject to the availability of lawfully appropriated funds.

Manager: Phillips, Brian R. - Mgr Project Management
Director: Conner, Sean M. - W/WW Project Engineering & Construction

VP: Vu, Hai X. - VP Water Wastewater Systems

APPROVALS:

Stephen Daty 5/5/22
Chairman, Awards Committee Date

S. D. 05.06.22
Elmore, Steven D. Date
Budget Representative



Formal Bid and Award System

Award #6 March 24, 2022

Type of Award Request: CONTRACT INCREASE
Requestor Name: Clendening, William
Requestor Phone: (904) 665-4723
Project Title: Construction Management-at-Risk (CMAR) Services for the Buckman Biosolids Conversion Projects
Project Number: 8004764
Project Location: JEA
Funds: Capital
Budget Estimate: \$14,545,786.00

Scope of Work:

The scope of work to be performed under this solicitation consists of CMAR services for the Buckman Biosolids Conversion Projects. This project is needed to update the treatment process at the Buckman Water reclamation Facility (WRF) to meet current and future needs. The projects to be constructed are listed below:

1. Biosolids Process Facility
2. Operations and Maintenance (O&M) Building
3. Ultraviolet (UV) Disinfection
4. Blower Improvements and Electrical Building

JEA IFB/RFP/State/City/GSA#: 086-19
CPA# 187261
Purchasing Agent: Kruck, Daniel R.
Is this a Ratification?: NO

RECOMMENDED AWARDEE(S):

Name	Contact Name	Email	Address	Phone	Amount
WHARTON-SMITH INC.	Nathan Hillard	nhillard@whartonsmith.com	PO Box 471028, Lake Monroe, FL 32747-1028	(407) 321- 8410	\$14,397,053.00

Amount of Original Award: \$971,322.00
Date of Original Award: 12/19/2019
Contract Increase Amount: \$14,397,053.00

List of Previous Change Order/Amendments:

CPA #	Amount	Date	Reason
187261	\$13,825,095.00	09/03/2020	Purchase and installation of the blower system improvements and site setup
187261	\$17,800,520.00	03/25/2021	Purchase and installation of the ultra-violet (UV) disinfection system

New Not-To-Exceed Amount: \$46,993,990.00
Length of Contract/PO Term: Project Completion

Begin Date: 01/06/2020
End Date: Project Completion (Expected: September 2024)
JSEB Requirement: Optional

Comments on JSEB Requirements:

Original Award
N/A

1st Contract Increase
ESB Security (Security) - 1.8%
Complete Coatings (Painting) - 0.85%

2nd Contract Increase
N/A – Specialty Equipment Purchase and Installation

This Contract Increase
JSEB Survey Allowance - \$30,020.00

Background/Recommendations:

Originally bid and approved by Awards Committee on 12/19/2019 in the amount of \$971,322.00 for pre-construction services to Wharton-Smith, Inc. A contract increase in the amount of \$13,825,095.00 was approved by the Awards Committee on 09/03/2020 for the purchase and installation of the blower system improvements. A contract increase in the amount of \$17,800,520.00 was approved by the Awards Committee on 03/25/2021, for the purchase and installation of the ultra-violet disinfection system. A copy of the previous awards are attached as backup.

This contract increase is for an early out package with a guaranteed maximum price (GMP) for site work and improvements, the purchase of an Alfa Laval Centrifuge unit, and Andritz Dryer support services.

The negotiated price of this early work package of \$14,397,053.00 is approximately 1% below the estimate for this work. JEA reviewed the CMAR GMP proposal and deemed the results reasonable when compared to past projects. A copy of the quote is attached as backup. As design progresses for the other aspects of the overall Buckman Biosolids Conversion Projects, additional GMPs will be brought before the Awards Committee.

Request approval to award a contract increase to Wharton-Smith, Inc. for the early work package as part of the Buckman Biosolids Conversion Projects in the amount of \$14,397,053.00, for a new not-to-exceed amount of \$46,993,990.00, subject to the availability of lawfully appropriated funds.

Manager: Phillips, Brian R. - Mgr Project Management
Director: Conner, Sean M. - W/WW Project Engineering & Construction
VP: Vu, Hai X. - VP Water Wastewater Systems

APPROVALS:

 3/24/22

Chairman, Awards Committee **Date**

 3/24/22

Hai X. Vu, VP Water/Wastewater Systems **Date**



Formal Bid and Award System

Award #12 March 25, 2021

Type of Award Request: CONTRACT AMENDMENT
Requestor Name: Clendening, William
Requestor Phone: (904) 665-4723
Project Title: Construction Management-at-Risk (CMAR) Services for the Buckman Biosolids Conversion Projects
Project Number: 8003631
Project Location: JEA
Funds: Capital
Budget Estimate: \$15,119,011.00

Scope of Work:

The scope of work to be performed under this solicitation consists of CMAR services for the Buckman Biosolids Conversion Projects. This project is needed to update the treatment process at the Buckman Water reclamation Facility (WRF) to meet current and future needs. The projects to be constructed are listed below:

1. Biosolids Process Facility
2. Operations and Maintenance (O&M) Building
3. Ultraviolet (UV) Disinfection
4. Blower Improvements and Electrical Building

JEA IFB/RFP/State/City/GSA#: 086-19
CPA# 187261
Purchasing Agent: Kruck, Daniel R.
Is this a Ratification?: NO

RECOMMENDED AWARDEE(S):

Name	Contact Name	Email	Address	Phone	Amount
WHARTON-SMITH INC.	Nathan Hillard	nhillard@whartonsmith.com	PO Box 471028, Lake Monroe, FL 32747-1028	(407) 321- 8410	\$17,800,520.00

Amount of Original Award: \$971,322.00
Date of Original Award: 12/19/2019
Contract Increase Amount: \$17,800,520.00

List of Previous Change Order/Amendments:

CPA #	Amount	Date	Reason
187261	\$13,825,095.00	09/03/2020	Purchase and installation of the blower system improvements and site setup

New Not-To-Exceed Amount: \$32,596,937.00
Length of Contract/PO Term: Project Completion
Begin Date: 01/06/2020
End Date: Project Completion (Expected: September 2024)

JSEB Requirement: Optional

Comments on JSEB Requirements:

Original Award

N/A

Previous Contract Increase

ESB Security (Security) - 1.8%

Complete Coatings (Painting) - 0.85%

This Contract Increase

N/A – Specialty Equipment Purchase and Installation

Background/Recommendations:

Originally bid and approved by Awards Committee on 12/19/2019 in the amount of \$971,322.00 for pre-construction services to Wharton-Smith, Inc. A contract increase in the amount of \$13,826,095.00 was approved by the Awards Committee on 09/03/2020 for the purchase and installation of the blower system improvements. A copy of the previous awards are attached as backup.

This contract increase is for an early out package with a guaranteed maximum price (GMP) for the purchase and installation of the ultra-violet (UV) disinfection system.

Negotiations with Wharton-Smith, Inc. were successfully completed for the purchase and installation of the UV system at the Buckman WRF. The negotiated price of \$17,800,520.00 is approximately 17.7% above the estimate due to the inclusion of Owner Allowances. During negotiations JEA opted to include Owner Allowances in the amount of \$4,399,290.00 to cover items on the risk register that are outside of the CMAR's control. JEA has control over these allowances, and these funds may not be used without JEA's prior authorization. If the Owner Allowances are not used, those funds will be reduced from the contract via addendum at the conclusion of this scope of work. JEA reviewed the CMAR GMP proposal and deemed the results reasonable when compared to past projects. A copy of the quote is attached as backup, which includes the listing of risk register items JEA added as Owner Allowances. As design progresses for the other aspects of the overall Buckman Biosolids Conversion Projects, additional GMPs will be brought before the Awards Committee.

Request approval to award a contract increase to Wharton-Smith, Inc. for the purchase of equipment and installation of the UV disinfection system replacement part of the Buckman Biosolids Conversion Projects in the amount of \$17,800,520.00, for a new not-to-exceed amount of \$32,596,937.00, subject to the availability of lawfully appropriated funds.

Manager: Collier, Bradley W. - Mgr Project Management

Director: Conner, Sean M. - W/WW Project Engineering & Construction

VP: Vu, Hai X. - VP Water/Wastewater Systems

APPROVALS:

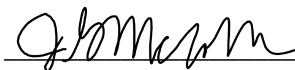
 03/25/2021

Chairman, Awards Committee **Date**

 03/25/2021

Hai X. Vu, VP Water/Wastewater Systems **Date**



Formal Bid and Award System

Award #2 September 3, 2020

Type of Award Request: CONTRACT INCREASE
Requestor Name: Clendening, William
Requestor Phone: (904) 665-4723
Project Title: Construction Management-at-Risk (CMAR) Services for the Buckman Biosolids Conversion Projects
Project Number: 8004764, 8004746
Project Location: JEA
Funds: Capital
Budget Estimate: \$14,953,336.00

Scope of Work:

The scope of work to be performed under this solicitation consists of CMAR services for the Buckman Biosolids Conversion Projects. This project is needed to update the treatment process at the Buckman Water reclamation Facility (WRF) to meet current and future needs. The projects to be constructed are listed below:

1. DigestivorePAD™
2. Biosolids Process Facility
3. Electrical and Instrumentation (E&I) Building
4. Operations and Maintenance (O&M) Building
5. Ultraviolet (UV) Disinfection
6. Blower Improvements and Electrical Building

JEA IFB/RFP/State/City/GSA#: 086-19
CPA# 187261
Purchasing Agent: Kruck, Daniel R.
Is this a Ratification?: NO

RECOMMENDED AWARDEE(S):

Name	Contact Name	Email	Address	Phone	Amount
WHARTON-SMITH INC.	Nathan Hillard	nhillard@whartonsmith.com	PO Box 471028, Lake Monroe, FL 32747-1028	(407) 321- 8410	\$13,825,095.00

Amount of Original Award: \$971,322.00
Date of Original Award: 12/19/2019
~~Contract Increase~~ **Contract Increase Amount:** \$13,825,095.00
New Not-To-Exceed Amount: \$14,796,417.00
Length of Contract/PO Term: Project Completion
Begin Date (mm/dd/yyyy): 01/06/2020
End Date (mm/dd/yyyy): Project Completion (Expected: September 2024)
JSEB Requirement: Optional

Comments on JSEB Requirements:

Original Award

N/A

This Contract Increase

ESB Security (Security) - 1.8%

Complete Coatings (Painting) - 0.85%

Background/Recommendations:

Originally bid and approved by Awards Committee on 12/19/2019 in the amount of \$971,322.00 for pre-construction services to Wharton-Smith, Inc. A copy of the original award is attached as backup.

This contract increase is for an early out package with a guaranteed maximum price (GMP) for the setup of field offices, and the purchase and installation of the blower system improvements.

Negotiations with Wharton-Smith, Inc. were successfully completed for the site setup (\$1,766,555.00) and the purchase and installation of the blower system improvements (\$12,058,540.00). The negotiated price of \$13,825,095.00 is approximately 7.5% below the estimate. JEA reviewed the CMAR GMP proposals and deemed the results reasonable when compared to past projects. A copy of the quotes are attached as backup. As design progresses for the other aspects of the overall Buckman Biosolids Conversion Projects, additional GMPs will be brought before the Awards Committee.

The contract increase spend details are below:

- FY21: \$8,958,517.00
- FY22: \$4,135,519.00
- FY23: \$417,748.00
- FY24: \$313,311.00

Request approval to award a change order to Wharton-Smith, Inc. for the purchase of equipment and installation of the blower system improvements and site setup as part of the Buckman Biosolids Conversion Projects in the amount of \$13,825,095.00, for a new not-to-exceed amount of \$14,796,417.00, subject to the availability of lawfully appropriated funds.

Manager: Collier, Bradley W. - Mgr Project Management
Director: Conner, Sean – W/WW Project Engineering & Construction
Chief: Vu, Hai – Interim GM Water/Wastewater Systems

APPROVALS:

 _____ 09/03/2020

Chairman, Awards Committee **Date**

Steven Elmore 09/03/2020

Budget Representative **Date**



Formal Bid and Award System

Award #4 December 19, 2019

Type of Award Request: PROPOSAL (RFP)
Request #: 6567
Requestor Name: Clendening, William
Requestor Phone: (904) 665-4723
Project Title: Construction Management-at-Risk (CMAR) Services for the Buckman Biosolids Conversion Projects - Phase 1
Project Number: 8004764, 8003631, 8004765, 8004746
Project Location: JEA
Funds: Capital
Budget Estimate: \$879,674.00 (Phase 1 Estimate)

Scope of Work:

The scope of work to be performed under this solicitation consists of CMAR services for the Buckman Biosolids Conversion Projects. This project is needed to update the treatment process at the Buckman Water reclamation Facility (WRF) to meet current and future needs. The projects to be constructed are listed below:

1. DigestivorePAD™
2. Biosolids Process Facility
3. Electrical and Instrumentation (E&I) Building
4. Operations and Maintenance (O&M) Building
5. Ultraviolet (UV) Disinfection
6. Blower Improvements and Electrical Building

This award positively impacts all of JEA's Measures of Value:

- Customer Value: Improve customer's service by providing additional capacity and reliable operation
- Community Value: Provide additional capacity and redundancy to meet existing and future growth
- Environmental Value: Provide high level treatment of biosolid waste
- Financial Value: Provide the most energy efficient process equipment and upgrades to improve operations and reduce energy requirements

JEA IFB/RFP/State/City/GSA#: 086-19
Purchasing Agent: Kruck, Daniel R.
Is this a Ratification?: NO

RECOMMENDED AWARDEE(S):

Name	Contact Name	Email	Address	Phone	Amount
WHARTON-SMITH INC	Nathan Hillard	nhillard@whartonsmith.com	PO Box 471028, Lake Monroe, FL 32747-1028	(407) 321-8410	\$971,322.00

Amount for entire term of Contract/PO: \$971,322.00
Award Amount for remainder of this FY: \$700,000.00
Length of Contract/PO Term: Project Completion
Begin Date (mm/dd/yyyy): 01/06/2020
End Date (mm/dd/yyyy): Project Completion (Expected: September 2024)

JSEB Requirement:

Optional for Phase 1

Comments on JSEB Requirements:

No JSEB participation in Phase 1. Contractor will meet JSEB goals during Phase 2.

PROPOSERS:

Name	Amount	Rank
WHARTON-SMITH, INC.	\$971,322.00	1
THE HASKELL COMPANY	N/A	2
GARNEY COMPANIES INC.	N/A	3
BRASFIELD & GORRIE, LLC	N/A	4
ULLIMAN SCHUTTE CONSTRUCTION LLC	N/A	5
CLARK CONSTRUCTION GROUP, LLC	N/A	6
PC CONSTRUCTION COMPANY	N/A	7
MWH CONSTRUCTORS, INC.	N/A	8

Background/Recommendations:

Advertised on 06/06/2019. Ten (10) prime companies attended the mandatory pre-proposal meeting held on 06/19/2019. At proposal opening on 07/16/2019, JEA received eight (8) Proposals. The public evaluation meeting was held on 09/10/2019 and JEA deemed Wharton-Smith, Inc. most qualified to perform the work. A copy of the evaluation matrix and negotiated fees are attached as backup.

Negotiations with Wharton-Smith, Inc. were successfully completed for Phase 1 of this project. Phase 1 consists of developing the project schedule, design and constructability reviews, developing work packages, value engineering and developing the Guaranteed Maximum Price (GMP) for each project. These preconstruction costs are 1.27% of the estimated construction costs. The percentage is slightly higher than JEA has seen in recent projects, however, JEA authorized extensive subsurface investigation allowances in this fee due to previous subsurface issues at the Buckman WRF. The Phase 1 fee is deemed reasonable when that is taken into consideration (industry standard is 0.5% - 3% of total construction costs). If negotiations for the final GMP are not successful, JEA reserves the right not to proceed with construction with this contractor. The contractor reviewed the current design estimates and deemed them reasonable for these projects.

The project details are below:

- Planning Project Budget (2017): \$37,188,000.00
 - Engineering Budget: \$4,648,500.00
 - Construction Budget: \$30,990,000.00
 - Internal JEA Costs: \$1,549,500.00
- Revised Project Budget: \$86,868,345.00
 - Engineering Budget (Carollo Engineering & Jacobs Engineering): \$7,111,874.00
 - Construction Budget: \$77,333,282.00
 - **Phase 1: \$971,322.00 (this award)**
 - Phase 2: \$76,361,960.00
 - Internal JEA Costs: \$2,423,189.00
- Original Project Schedule:

- Engineering Completion: March 2019
- Construction Completion: December 2020
- Revised Schedule:
 - Engineering Completion: November 2020
 - Construction Completion: February 2024

Major Changes/Issues

Project costs and schedule has increased significantly since the project definition phase. The design engineer has worked with JEA to make corrections, which has increased the cost and elongated the project schedule.

1. DigestivorePAD™ - It was determined during preliminary design that the original costs for the PAD process was underestimated during the initial study and project description (PD) development phase. Circular structure was revised to rectangular structure for redundancy purposes. Additional cost is approximately \$6.9 MM.
2. Biosolids Process Facility – Two buildings are proposed in lieu of one building. Height and footprint, along with increase in PAD siting dictated. It was determined that the sludge quantity was underestimated during the study; thereby, increasing size of equipment and building. Additional cost is approximately \$20.6 MM.
3. Electrical and Instrumentation Building – in lieu of new building, repurposing of existing building is proposed
4. Operations and Maintenance Building – in lieu of new building, repurposing of existing building is proposed
5. Disinfection Improvements – This project is included in the CMAR for economies of scale. Original project was stand-alone effort. Original PD was based on implementation of hypochlorite system. Permitting requirements drove the design to a UV system. Design addressed hydraulic constraints which were not in the original PD. Initial task is for CMAR to perform value engineering and cost estimate for this project to determine the path forward. Additional cost is approximately \$6.1 MM.
6. Blower Improvements – This project is included in the CMAR for economies of scale. Original project was stand-alone effort. PAD structure size forced the relocation of existing switchgear and transformers. Other site constraints combined the electrical into new standalone building to site both the Blower expansion and PAD equipment. Additional cost is approximately \$2.1 MM.

The current estimate is the design engineer’s opinion of probable construction cost at 30% and 60% design. CMAR will perform a detailed analysis of actual construction costs and will update these estimates periodically as design progresses and the project approaches a GMP.

086-19 – Request approval to award a contract to Wharton-Smith, Inc., for pre-construction services for the Buckman WRF projects in the amount of \$971,322.00, subject to the availability of lawfully appropriated funds.

Manager: Collier, Bradley W. - Mgr Project Management
Director: Conner, Sean M. – Dir W/WW Project Engineering & Construction
VP: Calhoun, Deryle I. - VP/GM Water Wastewater Systems

APPROVALS:

ABeard 12/19/19

Chairman, Awards Committee **Date**

Kristine Quate 12/19/19

Manager, Operating Budgets **Date**

SECTION 1 – EXECUTIVE SUMMARY

February 3, 2023

Mr. Bill Clendening
JEA Buckman WRF
2221 Buckman Street
Jacksonville, FL 32206

Re: JEA Buckman WRF
Biosolids Early Package 2 – GMP (Final)

Dear Mr. Clendening:

Wharton-Smith is pleased to submit the Guaranteed Maximum Price (GMP Final) for the JEA Buckman WRF Biosolids – Early Package 2. A comprehensive breakdown of material, equipment, subcontractor, and labor is provided in the supporting documentation following this letter. The GMP is valued at **\$14,514,773** for the Early Package 2 scope of work.

Please note the following clarifications regarding this proposal:

1. We have included all work in accordance with Carollo Engineers drawings Biosolids Capital Conversion Projects Early Package 2 dated October 2022 as well as the revisions as part of Addendum No. 1. Please note that there are items shown within the plan set that are not included as part of the Early Package 2 and will be included in the overall Biosolids Capital Conversion Projects GMP. The Early Package 2 scope of work includes the following:
 - a. Master Plant Contractor Underground Mechanical – Reference highlighted mechanical scope drawing included within Section 3
 - b. Gravity Belt Thickener Equipment Package Procurement
 - c. Bridge Cranes Package Procurement
 - d. Elevator Package Procurement
2. Please refer to Section 2 for the GMP Cost Summary, Directs, and General Conditions.
3. Our GMP includes an open book master plant contractor underground mechanical self-perform package. A detailed cost estimate and backup has been included in Section 3.
4. A list of the competitively bid work packages, bid tabulations and evaluations, and the recommended low responsive bidder for each is located in Section 4.
5. The Contingencies and Owner Allowances carried within this GMP are reflective of the proposed Risk Register included in Section 5.
 - a. Please note that the allowances are currently shown below the line without fee, fee to be included on allowance usage once brought into the project as approved by JEA.
6. Please reference Section 6 for the proposed GMP schedule for the Buckman WRF Biosolids Early Package 2 work. Our current estimated duration of construction is 12 months. We have included project management staff that is appropriate for this project. Please refer to the attached GC breakdown included within Section 3 for this phase of work.
7. We have the following clarifications for the team's review and consideration:
 - a. Storm water pollution prevention (SWPPP) is included.

- b. We have included a performance and payment bond, and insurances.
- c. ERP, FDEP, FDOT, & ROW permit costs are by others.
- d. We have not included costs within this GMP for the CMAR Mobilization/Trailer Compound.
- e. It is assumed that the JEA will provide power and water for use during construction and startup activities at no cost.
- f. No Davis-Bacon, other prevailing wage requirements, or American Iron and Steel (AIS) provisions are incorporated in the pricing at this time.
- g. We have not included any additional Lead or Asbestos Survey for demolition of existing structures.
- h. We have included an industry norm surveying budget within the general conditions. We will be utilizing Smith Surveying (JSEB) at their unit rates we are using on the other Buckman WRF projects. Any remaining budget will be returned to JEA upon completion of the project.

As always, I am available to discuss at your earliest convenience.

Very respectfully,



Josh Burns
Sr. Preconstruction Manager
Wharton-Smith, Inc.



COST SUMMARY

	LABOR	EQUIPMENT	MATERIALS	SUBS	TOTALS
Total Direct Costs	\$ 1,276,002	\$ 1,401,746	\$ 5,280,625	\$ 1,847,461	\$ 9,805,834
Sales Tax on Purchase Orders				\$ 396,047	\$ 396,047
Total GC's	\$ 869,908	\$ -	\$ 134,053	\$ 110,520	\$ 1,114,481
Contingency (Per Risk Register)				\$ 265,000	\$ 265,000
Bond				\$ 120,186	\$ 120,186
Insurance (0.75%)				\$ 108,861	\$ 108,861
Fee (8.75%)				\$ 1,033,411	\$ 1,033,411
SUBTOTAL	\$2,145,910	\$1,401,746	\$5,414,678	\$3,881,486	\$12,843,820
Escalation Contingency				\$ 314,876	\$ 314,876
Owner Allowance (Per Risk Register)				\$ 1,356,077	\$ 1,356,077
TOTAL					\$14,514,773



Formal Bid and Award System

Award #6 March 2, 2023

Type of Award Request: RENEWAL
Requestor Name: Shepherd, Bridget L.- Data Warehouse Specialist
Requestor Phone: (904) 665-4252
Project Title: Data Integration Platform as a Service (PaaS)
Project Number: B0700
Project Location: JEA
Funds: O&M
Budget Estimate: \$500,000.00

Scope of Work:

The purpose of this Invitation to Negotiate (the "ITN") for the data integration project is to evaluate and select a vendor that can provide a software tool to develop, manage, and maintain a modern data integration pipeline and facilitate accessibility to the data in a more secure and efficient manner.

The software solution includes the following functionalities:

- Operate and be maintained as a hybrid hosted cloud and on-premises solution
- Integrate data across a variety of platforms
- Include an intuitive, graphical user interface for extract, transform, load (ETL), Change Data Capture (CDC) and Services development
- Handle complex transformations from a variety of data source types, platforms and velocities
- Support and/or integrate easily with 3rd party monitoring, governance and security tools.
- Support ingestion of external metadata for agile development
- Support Single Sign-on and integration with Active Directory

After launch includes technical support for system administrator and developers.

JEA IFB/RFP/State/City/GSA#: CPA 187358
Purchasing Agent: Dambrose, Nickolas C.
Is this a Ratification?: NO

RECOMMENDED AWARDEE(S):

Name	Contact Name	Email	Address	Phone	Amount
DLT SOLUTIONS, LLC	Kristopher Crummett	kristopher.crummett@dlt.com	2411 Dulles Corner Park Suite 800 Herndon, VA 20171	(571) 346-1882	\$399,377.21

Amount of Original Award: \$516,139.60
Date of Original Award: 01/16/2020
Renewal Amount: \$399,377.21

List of Previous Change Orders / Amendments:

CPA #	Amount	Date
187358	\$31,850.21	05/25/2021

Length of Contract / PO Term: Three (3) Years w/Two (2) - One (1) Yr. Renewals (Software Subscription)
New Not-To-Exceed Amount: \$947,367.02
Begin Date (mm/dd/yyyy): 04/01/2020
End Date (mm/dd/yyyy): 03/31/2025
Renewal Options: None remaining
JSEB Requirement: JSEBs were reviewed and no opportunities available

Background/Recommendations:

Originally competitively bid and approved by Awards Committee on 01/16/2020 in the amount of \$516,139.60 to DLT Solutions, LLC. On 05/25/2021, JEA completed an administrative increase in the amount of \$31,850.21 for a slight scope modification to better align with JEA’s business requirements. An additional platform was needed to allow for capturing data changes. A copy of the original award is attached as backup.

This request is for additional funding of \$399,377.21 for a two (2) year contract renewal for the original purchased product suite, from 04/01/2023 to 03/31/2025 to maintain the existing software subscription and support. DLT is an authorized reseller of the Informatica Suite of Tools that JEA is using to build and maintain JEA’s Enterprise Data Warehouse for data analysis and reporting. DLT Solutions, LLC has performed well over the initial term of the contract and will keep rates the same for the two (2) year renewal.

Procurement tracks two different types of savings. The total cost difference is comparing the current pricing with the proposed pricing (+/-). The total sourcing savings is determined by negotiations, BAFO savings and value-added savings. JEA decided to request a two (2) year renewal instead of a one (1) year renewal which will save JEA 4% or \$19,197.00. A copy of the renewal quote is attached as backup. JEA anticipates re-soliciting these services upon completion of this contract renewal. Below is the result for this award.

- Total cost difference: N/A
- Total sourcing savings: \$19,197.00

Request approval to award a two (2) year contract renewal to DLT Solutions, LLC for Data Integration Platform as a Service (PaaS) in the amount of \$399,377.21, for a not-to-exceed amount of \$947,367.02 subject to the availability of lawfully appropriated funds.

Director: Eaton, Michael – Director Enterprise Data and Integration
VP: Selders, Steven G. – VP Application Delivery and Enterprise Architecture
Chief: Krol, Bradley D. – Chief Information Officer

APPROVALS:

Chairman, Awards Committee **Date**

Budget Representative **Date**



Price Quotation

Quote: 5129316
 Reference: 1753870
 Date: 01/30/2023
 Expires: 03/30/2023

To: Jenny McCollum
 Jacksonville Electric Authority
 21 West Church Street
 Jacksonville, FL 32202

From: Nick Rosati
 DLT Solutions, LLC
 2411 Dulles Corner Park
 Suite 800
 Herndon, VA 20171

Phone: (904) 665-4103
 Fax:
 Email: gleejs@jea.com

Phone: (703) 773-9270
 Fax: (703) 773-9270
 Email: nick.rosati@dlit.com

#	DLT Part No.	MFG Part No.	Contract	Qty	Unit Price	Ext. Price
1	9048-39943	0000025269-0000	OM	1	\$44,336.84	\$44,336.84
LEGACY - Data Engineering Integration Developer Edition (S) Production Annual Subscription Q-173586						
PoP: 3/31/2023 through 3/30/2025						
2	9048-39944	0000025237-0000	OM	5	\$8,867.37	\$44,336.85
LEGACY - Data Engineering Streaming Developer Named User (S) Production Annual Subscription						
PoP: 3/31/2023 through 3/30/2025						
3	9048-39946	0000025275-0000	OM	5	\$8,867.37	\$44,336.85
LEGACY - Data Engineering Persistent Masking Developer (Per Named User) (S) Production Annual Subscription						
PoP: 3/31/2023 through 3/30/2025						
4	9048-34260	0000023233-0000	OM	1	\$18,621.47	\$18,621.47
PowerExchange CDC Publisher Option for Apache Kafka (S) Production Annual Subscription						
PoP: 3/31/2023 through 3/30/2025						
5	9048-34678	0000024055-0000	OM	10	\$7,448.59	\$74,485.90
PowerExchange for Database - Oracle CDC Option Per Instance (S) Annual Subscription						
PoP: 3/31/2023 through 3/30/2025						
6	9048-34679	0000024057-0000	OM	10	\$7,448.59	\$74,485.90
PowerExchange for Database - SQL Server CDC Option Per Instance (S) Annual Subscription						
PoP: 3/31/2023 through 3/30/2025						
7	9048-32700	0000023304-0000	OM	1	\$1,954.43	\$1,954.43
LEGACY - Integration Base per consecutive month						
PoP: 3/31/2023 through 3/30/2025						
8	9048-34374	0000023558-0000	OM	1	\$2,928.24	\$2,928.24
LEGACY - Change Data Capture Standard package per consecutive month						
PoP: 3/31/2023 through 3/30/2025						



A TRON DATA COMPANY

Price Quotation

Quote: 5129316
Reference: 1753870
Date: 01/30/2023
Expires: 03/30/2023

#	DLT Part No.	MFG Part No.	Contract	Qty	Unit Price	Ext. Price
9	9048-34580	0000024066-0000	OM	6	\$1,464.118	\$8,784.71
LEGACY - Change Data Capture Relational Database Connectors per consecutive month						
PoP: 3/31/2023 through 3/30/2025						
10	9048-32701	0000023305-0000	OM	1	\$2,928.24	\$2,928.24
LEGACY - Data Integration per consecutive month						
PoP: 3/31/2023 through 3/30/2025						
11	0000009430-0000	0000009430-0000	OM	4	\$1,952.15	\$7,808.60
LEGACY - Informatica Cloud Secure Agent per consecutive month						
PoP: 3/31/2023 through 3/30/2025						
12	9048-32752	0000023322-0000	OM	1	\$488.04	\$488.04
Tier C Connectors per endpoint per consecutive month						
PoP: 3/31/2023 through 3/30/2025						
13	9048-34273	0000023250-0000	OM	6	\$1,220.096	\$7,320.58
LEGACY - Informatica DI Server Add-On Developer Named User (Per User) (S) Production Annual Subscription						
PoP: 3/31/2023 through 3/30/2025						
14	9048-34421	0000023684-0000	OM	1	\$66,560.56	\$66,560.56
Premium Success for Subscription: Excluded from PQT calculation. Premium Success for Subscription is calculated based on 20% of ACV.						
PoP: 3/31/2023 through 3/30/2025						
NOTE						
Customer shall make two (2) equal payments of \$197,402.88 (plus applicable taxes, if any) with the first such payment being due within thirty (30) days of receipt of DLT's Invoice which invoice shall be issued following execution of DLT Quote 5129316. DLT shall issue subsequent invoices annually thereafter, and payment shall be due within thirty (30) days of receipt of each such invoice						

Total \$399,377.21



Price Quotation

Quote: 5129316
Reference: 1753870
Date: 01/30/2023
Expires: 03/30/2023

Contract Number: OPEN MARKET
DUNS #: 78-646-8199
Federal ID #: 54-1599882
CAGE Code: 050H9
FOB: Destination
Terms: Net 30 (On Approved Credit)
DLT accepts VISA/MC/AMEX

UNLESS CONTROLLED BY AN EXISTING RESELLER PARTNER AGREEMENT OR OTHER WRITTEN CONTRACTUAL AGREEMENT BETWEEN YOU AND DLT, THIS QUOTE AND ANY RESULTING AWARD OR ORDER IS SUBJECT TO THE TERMS AND CONDITIONS POSTED AT [HTTPS://WWW.DLT.COM/PRODUCTS/CLIENT-COMMERCIAL-LICENSES](https://www.dlt.com/products/client-commercial-licenses). THESE TERMS CONTROL THE TERMS OF SALES AS WELL AS THE END USER'S USE OF THE PRODUCTS AND/OR SERVICES INCLUDED IN THIS QUOTE. BUYER IS DIRECTED TO INCORPORATE (BY REFERENCE) THIS QUOTE IN ANY RESULTING AWARD OR ORDER. THE TERMS AND CONDITIONS AT THE ABOVE LINK ARE THE ONLY CONTROLLING TERMS THAT WILL APPLY TO A RESULTING ORDER AND THE USE OF THE PRODUCTS AND/OR SERVICES INCLUDED IN THIS QUOTE. ANY ADDITIONAL OR INCONSISTENT TERMS ON BUYER'S ORDER THAT IN ANY WAY, MODIFY, ALTER OR NEGATE THE TERMS OF SALE OR THE MANUFACTURER'S END USER LICENSE AGREEMENT WILL NOT BE BINDING ON DLT OR ITS MANUFACTURERS AND SHALL NOT APPLY UNLESS SPECIFICALLY AGREED TO IN WRITING BY DLT AND THE MANUFACTURER. NO RETURNS ARE AUTHORIZED OF THE PRODUCTS AND/OR SERVICES INCLUDED IN THIS QUOTE. THE PRODUCTS AND/OR SERVICES INCLUDED IN THIS QUOTE ARE NONRECOURSE, NONCANCELLABLE, AND NON-RETURNABLE UNLESS EXPLICITLY AGREED TO IN WRITING BY DLT.

**PLEASE REMIT
PAYMENT TO:**

ACH: DLT Solutions, LLC
Bank of America
ABA # 111000012
Acct # 4451083799

-OR-

Mail: DLT Solutions, LLC
P.O. Box 743359
Atlanta, GA 30374-3359

Customer orders subject to applicable sales tax.

Documentation to be submitted to validate invoice for payment:

- a. Authorized Services shall be invoiced with a corresponding time report for the period of performance identifying names, days, and hours worked.
- b. Authorized reimbursable expenses shall be invoiced with a detailed expense report, documented by copies of supporting receipts.
- c. Authorized Education or Training shall be invoiced with a Report identifying date and name of class completed, and where applicable the name of attendees.



Formal Bid and Award System

Award #7 January 16, 2020

Type of Award Request: INVITATION TO NEGOTIATE (ITN)
Request #: 6672
Requestor Name: Shepherd, Bridget L.
Requestor Phone: 904-665-4252
Project Title: Data Integration Platform as a Service (PaaS)
Project Number: 8005580
Project Location: JEA
Funds: Capital and O&M (Year 2 and 3 Subscription cost)
Budget Estimate: \$500,000.00
Scope of Work:

The purpose of this Invitation to Negotiate (the "ITN") for the data integration project is to evaluate and select a vendor that can provide a software tool to develop, manage, and maintain a modern data integration pipeline and facilitate accessibility to the data in a more secure and efficient manner.

The software solution includes the following functionalities:

- Operate and be maintained as a hosted cloud, on-premise solution, platform as a solution
- Integrate data in a hybrid environment (Cloud, Multi-Cloud, Cloud-Ground scenarios)
- Include an intuitive, graphical user interface for extract, transform, load (ETL), Change Data Capture (CDC), Streaming and Services development
- Handle complex transformations from a variety of data source types, platforms and velocities
- Support and/or integrate easily with 3rd party monitoring, governance and security tools.
- Support ingestion of external metadata for agile development
- Support Single Sign-on and integration with Active Directory

After launch includes technical support for system administrator and developers.

This purchase impacts the following JEA measures of value:

- Customer: Expands the mechanisms of data integration in support of more real-time, consistent views of data for faster customer decision making
- Financial: Reduces the long-term need for multiple integration tools and skillsets to support a consolidated Enterprise Information Management framework

JEA IFB/RFP/State/City/GSA#: 131-19
Purchasing Agent: Dambrose, Nick
Is this a Ratification?: NO

RECOMMENDED AWARDEE(S):

Name	Contact Name	Email	Address	Phone	Amount
DLT SOLUTIONS, LLC	Kristopher Crummett	kristopher.crummett@dlt.com	2411 Dulles Corner Park Suite 800 Herndon, VA 20171	(571) 346-1882	\$516,139.60

Amount for entire term of Contract/PO: \$516,139.60
Award Amount for remainder of this FY: \$178,973.60
Length of Contract/PO Term: Three (3) Years w/Two (2) - One (1) Yr. Renewals (Software Subscription)
Begin Date (mm/dd/yyyy): 01/20/2020
End Date (mm/dd/yyyy): 01/19/2023
Renewal Options: YES - Two (2) - One (1) Yr. Renewals (Software Subscription)
JSEB Requirement: N/A - No JSEBs available.

RESPONDENTS:

Name	First Round	Disqualified	BAFO	Final Rank	Final Score
DLT/INFORMATICA	\$543,231.06	No	\$516,139.60	1	107.29
SAP	\$622,000.00	No	\$473,000.00	2	103.69
TALEND, INC	\$384,158.36	No	\$330,631.67	3	94.83
MYTHICS/ORACLE	\$680,877.72	No	\$697,403.69	4	72.13

Background/Recommendations:

Prior to bid solicitation, JEA completed a formal request for information (RFI) and demonstrations to gather business requirements and supplier information and received steering committee approval.

Advertised ITN on 08/28/2019. Four (4) prime contractors attended the optional pre-Response meeting held on 09/06/2019. At Response opening on 10/01/2019, JEA received four (4) Responses. JEA determined that the data integration tool should be delivered as a Platform as a Service (PaaS). In addition to price, the supplier Responses were also evaluated on Past Performance, Gartner's magic quadrant, and Ability to Meet the Business Requirements. DLT, Mythics, SAP, and Talend were short-listed and invited to present their solutions to the evaluation team. Upon completion of the vendor presentations, JEA solicited BAFO pricing for Platform as a Service (PaaS) delivery options only. DLT/Informatica was determined to be the highest ranking respondent due to highest scoring in quality factors for ability to meet the business requirements and presentation scoring despite not being the lowest priced solution. A copy of the detailed scoring summary, BAFO Response Form, and Workbook are attached as backup.

JEA currently utilizes two different Extract, Transform, Load (ETL) tools for data movement in the support and maintenance of its Enterprise Data Warehouse. The awarded solution consolidates on a Data Integration platform for continued support as well as the build-out of a newly proposed modern data pipeline and Enterprise Information Management program. This pipeline will be inclusive of a variety of different integration patterns (ETL/Extract, Load, Transform (ELT), CDC, Streaming, Services) depending on the use case(s) needed and the newly selected toolset must support each. Moving forward, JEA is looking to leverage Change Data Capture and services as the primary replication protocol when extracting data from its transactional systems and loading that data into a centralized staging repository which will serve as the foundation for provisioning data to downstream data repositories, applications and analytics.

DLT submitted a BAFO that improved their original pricing submission by \$27,091.46 or (5%). The award total of \$516,139.60 includes all costs for the (3) three-year term of the data integration software, support, maintenance, and training only. Implementation of this Solution shall be bid out separately. This purchase has already been approved by Technology Projects Committee (TPC). An additional budget trend will be submitted for additional funding.

Procurement tracks two different types of savings. The total cost difference is comparing the current pricing with the proposed pricing (+/-). The total sourcing savings is determined by negotiations, BAFO savings and value added savings. Below is the result for this award:

* Total cost difference: N/A

* Total sourcing savings: \$27,091.46 (5%)

131-19 – Request approval to award a contract to DLT Solutions, Inc. for the licensing, maintenance, support, and training of the Data Integration Solution for a total not-to-exceed amount of \$516,139.60, subject to the availability of lawfully appropriated funds.

Director: Selders, Steve G. - Dir IT Strategic Planning & Innovation

VP: Eads, Shawn W. - VP & Chief Information Officer

APPROVALS:

 _____ 

Chairman, Awards Committee **Date**

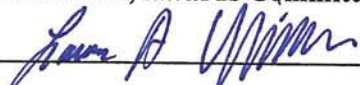
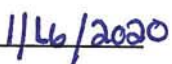
 _____ 

Manager, Capital Budget Planning **Date**

ITN# 131-19 - Data Integration Software as a Service (SaaS) or Platform as a Service (PaaS) or Infrastructure as a Service (IaaS)

Overall Average Vendor Scores	Appendix B - JEA Quotation of Rates (40 Points)	Round One - Written				Round Two - Presentation		Best and Final Offer		Final Total	
		Past Performance / Company Experience (20 Points)		Ability to Meet the Business Requirements (40 Points)	Total	Rank	Total	Rank	(BAFO) Appendix B - JEA Quotation of Rates (40 Points)	Final Total	Final Rank
		Min Qual References (10 Points)	Gartner's Magic Quadrant (10 Points)								
DLT/Informatica	28.29	6.33	10.00	35.00	79.62	1	30.3	1	25.62	107.29	1
Mythics Oracle	23.67	8.33	10.00	20.83	61.74	4	14.0	4	18.96	72.13	4
SAP	24.70	8.50	10.00	28.07	71.27	3	29.2	2	27.96	103.69	2
Talend	40.00	6.83	10.00	21.33	78.17	2	16.7	3	40.00	94.83	3
Chatman, Faye	Appendix B - JEA Quotation of Rates (40 Points)	Past Performance / Company Experience (20 Points)		Ability to Meet the Business Requirements (40 Points)	Total	Rank	Total	Rank	(BAFO) Appendix B - JEA Quotation of Rates (40 Points)	Final Total	Final Rank
DLT/Informatica	28.29	6.00	10.00								
Mythics Oracle	23.67	9.00	10.00	13.0	54.57	4	12	4	18.96	62.96	4
SAP	24.70	10.00	10.00	25.0	69.70	3	25	2	27.96	97.96	2
Talend	40.00	8.00	10.00	13.0	71.00	2	15	3	40.00	86.00	3
Herring, Jetonne	Appendix B - JEA Quotation of Rates (40 Points)	Past Performance / Company Experience (20 Points)		Ability to Meet the Business Requirements (40 Points)	Total	Rank	Total	Rank	(BAFO) Appendix B - JEA Quotation of Rates (40 Points)	Final Total	Final Rank
DLT/Informatica	28.29	6.00	10.00								
Mythics Oracle	23.67	8.00	10.00	29.5	70.07	4	19	3	18.96	85.46	4
SAP	24.70	7.50	10.00	32.2	74.40	3	31.5	1	27.96	109.16	1
Talend	40.00	4.50	10.00	27.0	81.50	1	18	4	40.00	99.50	2
Williams, Clarence	Appendix B - JEA Quotation of Rates (40 Points)	Past Performance / Company Experience (20 Points)		Ability to Meet the Business Requirements (40 Points)	Total	Rank	Total	Rank	(BAFO) Appendix B - JEA Quotation of Rates (40 Points)	Final Total	Final Rank
DLT/Informatica	28.29	7.00	10.00								
Mythics Oracle	23.67	8.00	10.00	20.0	60.57	4	11	4	18.96	67.96	4
SAP	24.70	8.00	10.00	27.0	69.70	3	31	1	27.96	103.96	2
Talend	40.00	8.00	10.00	24.0	82.00	1	17	3	40.00	99.00	3

Total Vendor Scores	Chatman, Faye	Herring, Jetonne	Williams, Clarence
DLT/Informatica	82.29	75.29	81.29
Mythics Oracle	54.57	70.07	60.57
SAP	69.70	74.40	69.70
Talend	71.00	81.50	82.00

Quotation Amounts	2nd Round Pricing	2nd Round Pricing Points	(BAFO) Pricing	(BAFO) Pricing Points
DLT/Informatica	\$ 43,291.06	28.3	\$ 516,139.60	25.62
Mythics Oracle	\$ 60,877.73	23.6	\$ 697,403.68	18.96
SAP	\$ 622,000.00	24.7	\$ 473,000.00	27.96
Talend	\$ 384,168.36	40.0	\$ 330,631.67	40.00

**#131-19 APPENDIX B - RESPONSE FORM (BAFO)
DATA INTEGRATION SOFTWARE AS A SERVICE (SaaS) OR PLATFORM AS A SERVICE (PaaS) OR
INFRASTRUCTURE AS A SERVICE**

Respondent shall complete and email this form to Nickolas Dambrose at dambnc@jca.com no later than the time indicated on the Best and Final Offer Invitation email.

Company Name: DLT Solutions

Company's Address 2411 Dulles Corner Park Suite 800 Herndon, VA 20171

Phone Number: 703-709-7172 FAX No: N/A Email Address: sales@dll.com

BID SECURITY REQUIREMENTS

- None required
- Certified Check or Bond Five Percent (5%)

TERM OF CONTRACT

- One Time Purchase
- Annual Requirements Three (3) Years w/One (1) – 1 Yr. Renewal
- Other, Specify- Project Completion

SAMPLE REQUIREMENTS

- None required
- Samples required prior to Response Opening
- Samples may be required subsequent to Bid Opening

SECTION 255.05, FLORIDA STATUTES CONTRACT BOND

- None required
- Bond required 100% of Bid Award

QUANTITIES

- Quantities indicated are exacting
- Quantities indicated reflect the approximate quantities to be purchased Throughout the Contract period and are subject to fluctuation in accordance with actual requirements.

INSURANCE REQUIREMENTS

Insurance required

PAYMENT DISCOUNTS

- 1% 20, net 30
- 2% 10, net 30
- Other _____
- None Offered

ENTER YOUR BID FOR THE FOLLOWING DESCRIBED ARTICLES OR SERVICES JEA Quotation of Rates	TOTAL BID PRICE
Data Integration Software - Total Bid Price (BAFO)	\$ 681,976.62

516,139.60
ND

I have read and understood the Sunshine Law/Public Records clauses contained within this solicitation. I understand that in the absence of a redacted copy my proposal will be disclosed to the public "as-is".

I confirm that the satisfaction of the business requirements contained in Appendix A – Business Requirements are contained within the TOTAL BID PRICE submitted above.

RESPONDENT CERTIFICATION

By submitting this Response, the Respondent certifies that it has read and reviewed all of the documents pertaining to this Solicitation, that the person signing below is an authorized representative of the Responding Company, that the Company is legally authorized to do business in the State of Florida, and that the Company maintains in active status an appropriate contractor's license for the work (if applicable). The Respondent also certifies that it complies with all sections (including but not limited to Conflict Of Interest and Ethics) of this Solicitation.

We have received addenda

1 through 7

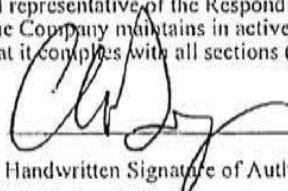

17DEC2019

Handwritten Signature of Authorized Officer of Company or Agent Date
DLT Solutions, LLC takes exception to any terms and conditions herein whether expressly stated or incorporated by reference. Terms and conditions shall be negotiated at the order level.

Chris Dewey VP Sales

Printed Name and Title

Dambrose, Nickolas C.

From: Kristopher Crummett <kristopher.crummett@dlt.com>
Sent: Monday, December 23, 2019 10:35 AM
To: Dambrose, Nickolas C.
Subject: RE: Informatica/JEA Appendix - Cloudoutsources document

[External Email - Exercise caution. DO NOT open attachments or click links from unknown senders or unexpected email.]

Hello Nickolas,

That is correct.

Thank you so much,

Kristopher Crummett

Account Manager

2411 Dulles Corner Park, Suite 800
Herndon, VA 20171

Main: 571-345-1882

Toll-Free: 800-262-4DLT (4358)

Email: kristopher.crummett@dlt.com



A TECH DATA COMPANY

Follow us on:

 [\[facebook.com\]](https://www.facebook.com/dlt.com)  [\[twitter.com\]](https://twitter.com/dlt.com)  [\[instagram.com\]](https://www.instagram.com/dlt.com)  [\[linkedin.com\]](https://www.linkedin.com/company/dlt.com)  [\[dlt.com\]](https://www.dlt.com)

From: Dambrose, Nickolas C. <dambnc@jea.com>
Sent: Monday, December 23, 2019 9:58 AM
To: Kristopher Crummett <kristopher.crummett@dlt.com>
Subject: RE: Informatica/JEA Appendix - Cloudoutsources document

Please confirm the three year term with maintenance, support, and training = \$505,749.99 + \$10,389.61 = 516,139.60

Nickolas Dambrose
Purchasing Agent Senior
Direct: (904) 665-7217



A TECH DATA COMPANY

Price Quotation

Quote: 4816584
Reference: 1493909
Date: 12/17/2019
Expires: 12/30/2019

To: Jenny McCollum
Jacksonville Electric Authority

From: Kristopher Crummett
DLT Solutions, LLC
2411 Dulles Corner Park
Suite 800
Herndon, VA 20171

Phone: (904) 665-4103
Fax:
Email: gleejs@jea.com

Phone: (571) 346-1882
Fax: (866) 708-7064
Email: kristopher.crummett@dl.com

#	DLT Part No.	MFG Part No.	Contract	Qty	Unit Price	Ext. Price
1	9048-39943	0000025269-0000	OM	1	\$72,916.66	\$72,916.66
Data Engineering Integration Developer Edition (S) Production Annual Subscription 36 Month Term PoP: 12/30/2019 through 12/29/2022						
2	9048-39944	0000025237-0000	OM	1	\$72,916.66	\$72,916.66
Data Engineering Streaming Developer 36 Month Term PoP: 12/30/2019 through 12/29/2022						
3	9048-34260	0000023233-0000	OM	1	\$30,625.00	\$30,625.00
PowerExchange CDC Publisher Option for Apache Kafka (S) Production Annual Subscription 36 Month Term PoP: 12/30/2019 through 12/29/2022						
4	9048-34678	0000024055-0000	OM	1	\$122,500.00	\$122,500.00
PowerExchange for Database - Oracle CDC Option Per Instance (S) Annual Subscription 36 Month Term PoP: 12/30/2019 through 12/29/2022						
5	9048-34679	0000024057-0000	OM	1	\$122,500.00	\$122,500.00
PowerExchange for Database - SQL Server CDC Option Per Instance (S) Annual Subscription 36 Month Term PoP: 12/30/2019 through 12/29/2022						
6	9048-34421	0000023684-0000	OM	1	\$84,291.67	\$84,291.67
Premium Success for Subscription 36 Month Term PoP: 12/30/2019 through 12/29/2022						

NOTE

Customer shall make three (3) payments, first such payment of \$168,583.33 and annually thereafter the second and third payment of \$168,583.33 (plus applicable taxes, if any). The first payment will be due within thirty (30) days of receipt of DLT Solution's invoice which will be issued following acceptance of Customer's purchase order. DLT shall issue a subsequent invoice annually thereafter, and payment shall be due within thirty (30) days of receipt of such invoice."



A TECH DATA COMPANY

Price Quotation

Quote: 4816584
 Reference: 1493909
 Date: 12/17/2019
 Expires: 12/30/2019

#	DLT Part No.	MFG Part No.	Contract	Qty	Unit Price	Ext. Price
	NOTE					
	Notwithstanding anything to the contrary in the Agreement, the offerings set forth above made available on a subscription basis may only be used by Customer during the number of months set forth above or such period as otherwise set forth in the Product or Cloud Description Schedule starting on the date the Software is made available to Customer as the case may be ('Subscription Period'). Unless the parties agree to renew the Subscription Period, upon expiration of the Subscription Period, Customer shall, and cause other authorized users to, cease use of and access to the Software, uninstall the Software from its systems, destroy all copies made thereof in whole or in part, including related technical documentation and certify to Informatica in writing that it has done so. Renewal of the Subscription Period shall be subject to additional fees.					
	NOTE					
	Contract Base Term is 36 Months (3 Years)					

Subtotal **\$505,749.99**

Option Year 1						
1	9048-39943	0000025269-0000	OM	1	\$25,277.77	\$25,277.77
	Data Engineering Integration Developer Edition (S) Production Annual Subscription 36 Month Term					
	PoP: 12/30/2019 through 12/29/2022					
2	9048-39944	0000025237-0000	OM	1	\$25,277.77	\$25,277.77
	Data Engineering Streaming Developer 36 Month Term					
	PoP: 12/30/2019 through 12/29/2022					
3	9048-34260	0000023233-0000	OM	1	\$10,616.66	\$10,616.66
	PowerExchange CDC Publisher Option for Apache Kafka (S) Production Annual Subscription 36 Month Term					
	PoP: 12/30/2019 through 12/29/2022					
4	9048-34678	0000024055-0000	OM	1	\$42,466.66	\$42,466.66
	PowerExchange for Database - Oracle CDC Option Per Instance (S) Annual Subscription 36 Month Term					
	PoP: 12/30/2019 through 12/29/2022					
5	9048-34679	0000024057-0000	OM	1	\$42,466.66	\$42,466.66
	PowerExchange for Database - SQL Server CDC Option Per Instance (S) Annual Subscription 36 Month Term					
	PoP: 12/30/2019 through 12/29/2022					
6	9048-34421	0000023684-0000	OM	1	\$29,221.11	\$29,221.11
	Premium Success for Subscription 36 Month Term					
	PoP: 12/30/2019 through 12/29/2022					

Subtotal for Option Year 1 **\$175,326.63**



A TECH DATA COMPANY

Price Quotation

Quote: 4816584
Reference: 1493909
Date: 12/17/2019
Expires: 12/30/2019

#	DLT Part No.	MFG Part No.	Contract	Qty	Unit Price	Ext. Price
---	--------------	--------------	----------	-----	------------	------------

Total						\$681,076.62
--------------	--	--	--	--	--	---------------------

Contract Number: OPEN MARKET
DUNS #: 78-646-8199
Federal ID #: 54-1599882
CAGE Code: 0S0H9
FOB: Destination
Terms: Net 30 (On Approved Credit)
DLT accepts VISA/MC/AMEX
DLT's standard Terms & Conditions apply

THIS QUOTE IS SUBJECT TO THE TERMS AND CONDITIONS AT <http://www.dlt.com/products/client-commercial-licenses> THAT APPLY TO THE PRODUCTS AND/OR SERVICES INCLUDED IN THIS QUOTATION. CUSTOMER IS DIRECTED TO INCORPORATE (BY REFERENCE) THIS QUOTE IN ANY RESULTING TASK/DELIVERY ORDER OR AWARD. THE TERMS OF THE AFOREMENTIONED CONTRACT ARE THE ONLY CONTROLLING TERMS AND ANY TERMS OR CONDITIONS CONTAINED IN AN ORDER, AWARD OR OTHER INSTRUMENT OF BUYER, WHICH ARE IN ADDITION TO OR INCONSISTENT WITH ANY OF THE TERMS OR CONDITIONS CONTAINED IN THOSE REFERENCED HEREIN, SHALL NOT BE BINDING ON DLT OR ITS MANUFACTURERS AND SHALL NOT APPLY UNLESS SPECIFICALLY AGREED TO IN WRITING BY DLT.

**PLEASE REMIT
PAYMENT TO:**

ACH: DLT Solutions, LLC
Bank of America
ABA # 111000012
Acct # 4451063799

-OR-

Mail: DLT Solutions, LLC
P.O. Box 743359
Atlanta, GA 30374-3359

Customer orders subject to applicable sales tax.

Documentation to be submitted to validate Invoice for payment:

- Authorized Services shall be invoiced with a corresponding time report for the period of performance identifying names, days, and hours worked.
- Authorized reimbursable expenses shall be invoiced with a detailed expense report, documented by copies of supporting receipts.
- Authorized Education or Training shall be invoiced with a Report identifying date and name of class completed, and where applicable the name of attendees.



Formal Bid and Award System

Award #7 March 2, 2023

Type of Award Request: SINGLE SOURCE
Requestor Name: Ellis, Randy J. – Mgr Wastewater Treatment and Reuse – St. Johns
Requestor Phone: 904-665-7133
Project Title: Kubota Membrane Changeout
Project Number: 8008051
Project Location: JEA
Funds: Capital
Business Unit Estimate \$535,192.00

Scope of Work:

This scope of work is for the purchase of 5,600 membranes and associated tubing, in the Membrane Bio-Reactor (MBR) Basin #3 at the Nassau Regional Water Reclamation Facility (WRF). Permit compliance and the ability to meet reuse customer demands are at risk if the membranes are not replaced.

JEA IFB/RFP/State/City/GSA#: N/A
Purchasing Agent: Rix, Lynn W.
Is this a Ratification?: NO

RECOMMENDED AWARDEE(S):

Name	Contact Name	Email	Address	Phone	Amount
KUBOTA MEMBRANE USA CORPORATION	Diego Ayala	cjy@mosskelley.com	11807 North Creek Parkway S., Unit B-109, Bothell, WA 98011	425-898-2858	\$535,192.00

Amount for entire term of Contract/PO: \$535,192.00
Award Amount for remainder of this FY: \$535,192.00
Length of Contract/PO Term: Project Completion
Begin Date: 03/03/2023
End Date: Project Completion (Estimated: April 2023)
JSEB Requirement: N/A

Background/Recommendations:

The Nassau WRF MBR process was designed to utilize the Ovivo Membrane (sold through Kubota). The Nassau WRF is the only facility in JEA to use this membrane technology.

Based on previous investigations with the manufacturer and the continuing operational experience of JEA, it has been determined that a five (5) year replacement cycle of the membranes is necessary to ensure continued operation of the plant in compliance with permit requirements. Since the

membranes were replaced in FY19 there has been a 42% price increase (from \$376,600.00 to \$535,192.00). This increase is deemed reasonable in the current economic environment. The quote for the work is attached for reference.

Request approval to award a contract to Kubota Membrane USA Corporation for the purchase of Nassau Regional WRF membranes and associated tubing in the amount \$535,192.00, subject to the availability of lawfully appropriated funds.

Director: Sgambettera, John J. – Dir. WW & Reuse Treatment

VP: Vu, Hai X. - VP Water Wastewater Systems

APPROVALS:

Chairman, Awards Committee	Date
-----------------------------------	-------------

Budget Representative	Date
------------------------------	-------------

Certification of Single Source or Emergency Procurement

Please use this form to certify a Single Source or Emergency Procurement complies with the requirements of the JEA Procurement Code. The JEA Procurement Code defines a Single Source and Emergency Procurement as follows:

3-112 Single Source

A Contract may be awarded for Supplies or Services as a Single Source when, pursuant to the Operational Procedures, the Chief Procurement Officer determines that:

- (a) there is only one justifiable source for the required Supplies or Services;
- (b) the Supplies or Services must be a certain type, brand, make or manufacturer due to the criticality of the item or compatibility within a JEA utility system, and such Supplies or Services may not be obtained from multiple sources such as distributors;
- (c) the Services are a follow-up of Services that may only be done efficiently and effectively by the Vendor that rendered the initial Services to JEA, provided the Procurement of the initial Services was competitive;
- (d) at the conclusion of a Pilot Project under Section 3-118 of this Code, the Procurement of Supplies or Services tested during the Pilot Project, provided the Vendor was competitively selected for the Pilot Project.

3-113 Emergency Procurements

In the event of an Emergency, the Chief Procurement Officer may make or authorize an Emergency Procurement, provided that Emergency Procurements shall be made with as much competition as practicable under the circumstances. A written Determination of the basis for the Emergency and for the selection of the particular Vendor shall be included in the Procurement file.

For purposes of this Section 3-113, an "Emergency" means any one of the following:

- (a) a reasonably unforeseen breakdown in machinery;
- (b) an interruption in the delivery of an essential governmental service or the development of a circumstance causing a threatened curtailment, diminution, or termination of an essential service;
- (c) the development of a dangerous condition causing an immediate danger to the public health, safety, or welfare or other substantial loss to JEA;
- (d) an immediate danger of loss of public or private property;
- (e) the opportunity to secure significant financial gain, to avoid delays to any Governmental Entity or avoid significant financial loss through immediate or timely action; or (f) a valid public emergency certified by the Chief Executive Officer.

Please provide the following information:

1. **Vendor Name:**

2. **Description of Services or Supplies provided by Vendor:**

3. Certification:

I the undersigned certify that to the best of my knowledge, no JEA employee has, either directly or indirectly, a financial interest in this Single Source Emergency Procurement, and

I the undersigned certify that this procurement meets the requirements of a (choose one of the following):

_____ **Single Source Procurement.** Please state which subsection of Section 3-112 above applies to this Single Source Procurement: _____

OR

_____ **Emergency Procurement** - Please state which subsection of Section 3-113 above applies to this Emergency Procurement: _____

_____ *Randy J. Ellis*
Signature of JEA Business Unit Manager

Date

Name of JEA Business Unit Manager

This certification shall be attached to the Purchase Order when it is routed for approval. A Single Source or Emergency Procurement shall be reported to the JEA Board in accordance with Section 1-110 of the JEA Procurement Code.

QUOTATION

KUBOTA Membrane USA Corporation
 11807 North Creek Parkway S., Unit B-109
 Bothell, WA 98011
 Tel:425-898-2858, Fax: 425-898-2853

Date: 12/21/2022
 Quotation No KMUAQ22-050

Messrs/Customer :
Mr. Anthony W. Fedderly JEA Nassau Regional WWRF 96237 Amelia Concourse Fernandina Beach, FL. 32034 Office- 904-665-4469 Cell- 904-476-1208

Ship To:
JEA Nassau Regional WWRF 96237 Amelia Concourse Fernandina Beach, FL. 32034

Dear valued customer,
 In compliance with your inquiry mentioned below, we are pleased to quote you as follows.

Payment Terms:
Due on receipt

Trade Terms:	
DDP	Fernandia Beach, FL

Delivery Term:	Estimated, 17 weeks after receipt of PO
----------------	---

Valid through	90 Days
---------------	---------

Item	Description	Qty	Unit Price	Currency	Amount
1	Membrane Cartridge H7-510-P100	56	8,800.00	USD	\$492,800.00
2	Tube TB500	5600	3.20	USD	\$17,920.00
3	Retaining rubber OGS50	224	15.50	USD	\$3,472.00
4	Freight	1	21,000.00	USD	\$21,000.00

The entire content of this Quotation is governed by the General Terms & Conditions of Kubota Membrane USA Corporation and/or Kubota Corpation. Tax: Applicable Sales/Local tax may apply pending Exempt confirmation(TBD).

Product Warranty	1 year	TOTAL PRICE (TAX EXCLUDED)	\$535,192.00
Customer Reference			



 Tatsuya Uejima
 Technical Support Manager

Date: 12/21/2022



 Diego Ayala
 President

Date: 12/21/2022



Formal Bid and Award System

Award #8 March 2, 2023

Type of Award Request: CONTRACT RENEWAL
Requestor Name: Keeler, Jessica
Requestor Phone: (904) 665-6403
Project Title: Electrical Conduit for JEA Inventory Stock
Project Number: Various
Project Location: JEA
Funds: Inventory Blanket Account
Budget Estimate: \$3,287,444.76

Scope of Work:

The purpose of this award is to exercise the final one (1) year renewal, with an increase in the dollar amount of the contract for Electrical Conduit for JEA Inventory Stock, to cover the remaining existing term and the renewal term. This agreement provides electrical conduit materials consisting of forty-seven (47) items for JEA Inventory Stock and Storm Stores. These items are used for providing underground utilities throughout the JEA system. Our current inventory balance for the items found in this contract is \$1,211,073.84 and the spend for the last year was \$1,714,009.96.

JEA IFB/RFP/State/City/GSA#: 1410334649-21
Purchasing Agent: Eddie Bayouth
Is this a ratification?: No

RECOMMENDED AWARDEE(S):

Name	Vendor Contact	Email	Address	Phone	Amount
ANIXTER INC.	Renee Lackey	Renee.lackey@anixter.com	3881 Old Winter Garden Road, Orlando, FL 32805	(352) 408-3898	\$3,287,444.76

Amount of Original Award: \$1,070,241.50
Date of Original Award: 07/15/2021
Contract Increase Amount: \$3,287,444.76
New Not-To-Exceed Amount: \$6,152,407.57

List of Previous Change Orders:

Name	Original Award	Contract Renewal	Contract Renewal	New Not to Exceed
Date	07/15/2021	06/16/2022	03/02/2023	03/02/2023
ANIXTER INC.	\$1,070,241.50	\$1,794,721.31	\$3,287,444.76	\$6,152,407.57

Length of Contract/PO Term: One (1) Year w/Two (2) – One (1) Yr. Renewals
Begin Date (mm/dd/yyyy): 09/01/2021
End Date (mm/dd/yyyy): 08/31/2024

Renewal Options: None remaining
JSEB Requirement: N/A – Optional

Background/Recommendations:

Originally competitively bid and awarded on 07/15/2021 to Anixter Inc. in the amount of \$1,070,241.50. Contract was renewed for one (1) year and amount was increased on 06/16/2022 to cover the execution of the first renewal option.

PVC conduit is a critical component in the JEA underground utility service. The proposed execution of the last contract renewal of one (1) year term and contract increase is needed to fully fund the estimated purchases of PVC conduit through 08/31/2024. The proposed award amount for Anixter Inc. is based upon future forecasts, the current price of materials, and orders placed to date. These increases are based primarily on three factors, the first and primary factor has been an increase in PVC pricing directly linked to PVC resin costs, which are the primary cost driver of the finished PVC pipe costs. JEA has experienced a 35% increase since the first renewal conducted in June of 2022, driven from PVC resin cost increases linked to adjustments per contract based on Chemical Data, Inc. index data.

The second factor in the annual projected spend has been attributed to an increase in demand based on new underground utility development within the JEA service territory. The amount proposed does not account for upwards or downwards price adjustments that align PVC resin indices values and finished goods pricing in accordance with contract and solicitation adjustment language, for orders that will occur in the future. Lastly, adding the additional one (1) year of term adds estimated usage to the overall value of the contract.

Request approval to award a contract renewal to Anixter Inc. for the supply of Electrical Conduit for JEA Inventory Stock in the amount of \$3,287,444.76, for a not-to-exceed amount of \$6,152,407.57, subject to the availability of lawfully appropriated funds.

Manager: Keeler, Jessica – Manager, Procurement Inventory Control
Director: McCollum, Jenny – Director, Procurement Services & Inventory Planning
VP: McElroy, Alan. – VP Supply Chain & Operations Support

APPROVALS:

Chairman, Awards Committee **Date**

Budget Representative **Date**

JEA Planner	Warehouse	JEA Item ID	Item Description	UOM	Min	Max	On Hand Quantity	Unit Cost	On Hand Value	Demand Quantity	Estimated 19 Months Usage	OHQ-(usage+demand)	PO Quantity
Mike	CSC Stores	CODAD009	ADAPTER, CONDUIT, PVC, SCH-40 W/LOCKNUT, MALE, 2"	EA	5	10	34	\$0.40	\$13.60	0.0	3	31	0.0
Mike	CSC Stores	CODAF010	ACCESS FITTING, 1", TYPE LB SCHEDULE 40, PVC	EA	10	20	26	\$4.08	\$106.08	21.0	108	-103	0.0
Renee	CSC Stores	CODBE001	BELL-END, 2", PVC, TYPE EB,	EA	6	20	30	\$8.05	\$241.50	0.0	8	22	0.0
Renee	CSC Stores	CODBE003	BELL-END, 4", PVC, TYPE EB,	EA	15	25	88	\$20.23	\$1,780.24	243.0	98	-253	0.0
Renee	CSC Stores	CODBE004	BELL END, 6 IN. TYPE EB	EA	10	30	113	\$30.55	\$3,452.15	334.0	57	-278	0.0
Mike	CSC Stores	CODCO004	COUPLING, CONDUIT, PVC, 3", SCH-40	EA	20	40	2325	\$7.87	\$18,297.75	854.0	362	1109	40.0
Mike	CSC Stores	CODCO006	COUPLING, CONDUIT, PVC, 6", TYPE SCH-40	EA	60	120	241	\$29.36	\$7,075.76	538.0	232	-529	0.0
Mike	CSC Stores	CODCO032	COUPLING, CONDUIT, SCH-40 PVC, REPAIR, 3" SLIP TYPE	EA	20	40	29	\$29.36	\$851.44	36.0	190	-197	50.0
Mike	CSC Stores	CODCO033	COUPLING, CONDUIT, SCH-40 PVC, REPAIR, 4" SLIP TYPE	EA	20	40	35	\$31.10	\$1,088.50	229.0	270	-464	0.0
Mike	CSC Stores	CODCO034	COUPLING, CONDUIT, SCH-40 PVC, REPAIR, 6" SLIP TYPE	EA	50	100	61	\$51.02	\$3,112.22	260.0	214	-413	200.0
Renee	CSC Stores	CODCO040	COUPLING, 2 INCH SPLIT-DUCT, 6" MINIMUM LENGHT.	EA	2	10	10	\$13.53	\$135.30	0.0	11	-1	0.0
Renee	CSC Stores	CODCO041	COUPLING, 3 INCH SPLIT-DUCT, 7" MINIMUM LENGHT.	EA	2	10	3	\$10.76	\$32.28	0.0	11	-8	0.0
Renee	CSC Stores	CODCO042	COUPLING, 4 INCH SPLIT-DUCT, 6" MINIMUM LENGHT.	EA	2	10	8	\$22.47	\$179.76	0.0	12	-4	0.0
Renee	CSC Stores	CODCO043	COUPLING, 6 INCH SPLIT-DUCT, 10" MINIMUM LENGHT.	EA	2	10	7	\$8.47	\$59.29	0.0	7	0	0.0
Renee	CSC Stores	CODEF002	CONNECTOR, FLEXIBLE PVC, 90-DEGREE, 1" PACKAGED 25-UNITS PER CARTON	EA	15	40	86	\$10.59	\$910.74	42.0	225	-181	0.0
Renee	CSC Stores	CODEP001	ELBOW, PVC, CONDUIT, 2", 45-DEGREE 36" SWEEP-RADIUS, SCH-40, WITH INTEGRAL BELL END	EA	30	60	140	\$15.26	\$2,136.40	89.0	236	-185	0.0
Renee	CSC Stores	CODEP002	ELBOW, PVC, CONDUIT, 2", 90-DEGREE 48" SWEEP-RADIUS, SCH-40, WITH INTEGRAL BELL END	EA	60	90	558	\$42.81	\$23,887.98	424.0	592	-458	0.0
Renee	CSC Stores	CODEP003	ELBOW, PVC, CONDUIT, 3", 45-DEGREE 36" SWEEP-RADIUS, SCH-40, WITH INTEGRAL BELL END	EA	10	30	758	\$30.53	\$23,141.74	520.0	313	-75	0.0

Renee	CSC Stores	CODEP004	ELBOW, PVC, CONDUIT, 3", 90-DEGREE 36" SWEEP-RADIUS, SCH-40, WITH INTEGRAL BELL END	EA	30	80	4218	\$38.16	\$160,958.88	1389.0	515	2314	0.0
Renee	CSC Stores	CODEP005	ELBOW, PVC, CONDUIT, 4", 45-DEGREE 36" SWEEP-RADIUS, SCH-40, WITH INTEGRAL BELLED END.	EA	60	150	207	\$43.06	\$8,913.42	173.0	340	-306	0.0
Renee	CSC Stores	CODEP006	ELBOW, PVC, CONDUIT, 4", 90-DEGREE 36" SWEEP-RADIUS, SCH-40, WITH INTEGRAL BELL END	EA	100	250	196	\$46.85	\$9,182.60	181.0	1,169	-1154	0.0
Renee	CSC Stores	CODEP008	ELBOW, PVC, CONDUIT, 6", 45-DEGREE 150" SWEEP-RADIUS, TYPE DB-60, WITH INTEGRAL BELLED END	EA	1	2	5	\$178.80	\$894.00	0.0	17	-12	0.0
Renee	CSC Stores	CODEP009	ELBOW, PVC, CONDUIT, 6", 90-DEGREE 48" SWEEP-RADIUS, SCH-40, WITH INTEGRAL BELLED END	EA	15	30	175	\$103.80	\$18,165.00	119.0	122	-66	0.0
Renee	CSC Stores	CODEP010	ELBOW, PVC, CONDUIT, 6", 45-DEGREE, 48" SWEEP-RADIUS, SCH-40, WITH INTEGRAL BELLED END	EA	15	30	85	\$99.20	\$8,432.00	80.0	72	-67	1.0
Renee	CSC Stores	CODEP011	ELBOW, PVC, CONDUIT, 6", 22.5-DEGREE 48" SWEEP-RADIUS, SCH-40, WITH INTEGRAL BELLED END	EA	10	30	32	\$42.51	\$1,360.32	0.0	46	-14	0.0
Renee	CSC Stores	CODEP013	ELBOW, PVC, CONDUIT, 6", 90-DEGREE 150" SWEEP-RADIUS, SCH-40, WITH INTEGRAL BELLED END	EA	0	0	0	\$300.00	\$0.00	0.0	0	0	0.0
Renee	CSC Stores	CODEP024	ELBOW, 1" PVC 90-DEGREE, 18" RADIUS SCH-40	EA	35	77	1049	\$11.36	\$11,916.64	900.0	349	-200	0.0
Renee	CSC Stores	CODEP030	ELBOW, REPAIR, PVC, CONDUIT, 4", 45-DEGREE, 36" SWEEP-RADIUS, SCH-40	EA	2	2	2	\$95.15	\$190.30	0.0	0	2	0.0
Renee	CSC Stores	CODEP031	ELBOW, REPAIR, PVC, CONDUIT, 6", 90-DEGREE, 36" SWEEP-RADIUS, SCH-40	EA	2	2	2	\$154.00	\$308.00	0.0	0	2	0.0
Renee	CSC Stores	CODEP032	ELBOW, REPAIR, PVC, CONDUIT, 4" 90-DEGREE 36" SWEEP-RADIUS	EA	1	2	2	\$100.00	\$200.00	0.0	0	2	0.0
Renee	CSC Stores	CODKT001	KIT, RISER PLUG, FOR CONDUIT RISERS AND CABLE GUARDS UP TO 6" DIAMETER.	EA	140	300	1419	\$61.31	\$86,998.89	464.0	872	83	0.0
Renee	CSC Stores	CODPC003	CONDUIT, PVC, 4", SCH-40, W/COUPLING ATTACHED OR ONE BELLED END, 20' SECTIONS END WITHOUT COUPLING MUST BE CHAMFERED 40-DEGREES SHIPPED ON OPEN FLAT BED TRUCK - STANDARD PALLET SIZE 1140 FT	FT	20,000	35,000	46218	\$9.13	\$421,970.34	54394.0	207,240	-215416	17000.0
Renee	CSC Stores	CODPC005	CONDUIT, PVC, 6", SCH-40, W/COUPLING ATTACHED OR ONE BELLED END, 20' SECTIONS END WITHOUT COUPLING MUST BE CHAMFERED 40-DEGREES SHIPPED ON OPEN FLAT BED TRUCK	FT	1,000	3,000	31513	\$7.58	\$238,868.54	13142.0	31,231	-12860	0.0
Renee	CSC Stores	CODPC012	CONDUIT, PVC, 4", SCH-40, SPLIT 10-FOOT SECTIONS SHIPPED ON OPEN FLAT BED TRUCK SUITABLE FOR FORKLIFT UNLOADING	FT	15	30	90	\$1.28	\$115.20	30.0	84	-24	0.0
Renee	CSC Stores	CODPC013	CONDUIT, PVC, 6", SCH-40, SPLIT-DUCT 10-FOOT SECTIONS SHIPPED ON OPEN FLAT BED TRUCK SUITABLE FOR FORKLIFT UNLOADING	FT	5	10	50	\$7.48	\$374.00	0.0	44	6	0.0

Renee	CSC Stores	CODPC014	CONDUIT, PVC, 2", SCH-40, SPLIT-DUCT 10-FOOT SECTIONS SHIPPED ON OPEN FLAT BED TRUCK SUITABLE FOR FORKLIFT UNLOADING	FT	10	20	0	\$0.09	\$0.00	20.0	64	-84	60.0
Renee	CSC Stores	CODPC015	CONDUIT, PVC, 3", SCH-40, SPLIT-DUCT 10-FOOT SECTIONS SHIPPED ON OPEN FLAT BED TRUCK SUITABLE FOR FORKLIFT UNLOADING	FT	10	30	200	\$2.49	\$498.00	0.0	160	40	0.0
Renee	CSC Stores	CODPC016	CONDUIT, PVC, 1" SCHEDULE-40, 10' LONG PACKAGED 10-UNITS PER BUNDLE	FT	800	1,800	11080	\$2.11	\$23,378.80	2827.0	10,797	-2544	0.0
Renee	CSC Stores	CODPC017	CONDUIT, FLEXABLE PVC, 1"NON-METALIC PACKAGED 100-FEET PER POLYPACK	FT	150	400	2350	\$1.88	\$4,418.00	660.0	3,042	-1352	0.0
Renee	CSC Stores	CODPC019	CONDUIT, PVC, 2", SCH-40, W/COUPLING ATTACHED OR ONE BELLED END, 20' SECTIONS END WITHOUT COUPLING MUST BE CHAMFERED 40-DEGREES SHIPPED ON OPEN FLAT BED TRUCK	FT	3,000	6,000	3460	\$4.10	\$14,186.00	489.0	28,287	-25316	0.0
Renee	CSC Stores	CODPC020	CONDUIT, PVC, 3", SCH-40, W/COUPLING ATTACHED OR ONE BELLED END, 20' SECTIONS END WITHOUT COUPLING MUST BE CHAMFERED 40-DEGREES SHIPPED ON OPEN FLAT BED TRUCK	FT	1,000	3,000	17140	\$6.42	\$110,038.80	2995.0	4,377	9768	0.0
Renee	CSC Stores	CODPL001	PLUG, CONDUIT, PVC, 2" ID, TYPE EB	EA	40	80	285	\$0.63	\$179.55	6.0	151	128	0.0
Renee	CSC Stores	CODPL004	PLUG, CONDUIT, PVC, 6" ID, TYPE EB	EA	20	60	262	\$4.38	\$1,147.56	230.0	138	-106	1.0
Renee	CSC Stores	CODPL005	PLUG, PVC CONDUIT, 1" I.D., CAP-TYPE	EA	40	100	212	\$1.62	\$343.44	178.0	179	-145	0.0
Renee	CSC Stores	CODRC043	COUPLING, CONDUIT REDUCER PVC SCH-40; 4" SPIGOT TO 3", WITH INTERNAL STOP	EA	14	26	90	\$9.01	\$810.90	0.0	3	87	0.0
Renee	CSC Stores	CODSC002	STRAP, CONDUIT, PVC, 1", 2-HOLE PACKAGED 400-UNITS PER CARTON	EA	25	53	30	\$0.36	\$10.80	0.0	40	-10	0.0
Renee	CSC Stores	CODWH002	WEATHERHEAD, PVC, 1" PACKAGED 15-UNITS PER CARTON	EA	10	25	49	\$5.75	\$281.75	21.0	131	-103	0.0
Renee	Storm Stores	CODKT001	KIT, RISER PLUG, FOR CONDUIT RISERS AND CABLE GUARDS UP TO 6" DIAMETER.	EA	24	24	14	\$30.67	\$429.38	0.0	48	0	0.0

\$1,211,073.84

Shortfall after PO	Est Need	Safety Stock (20%)	Change Order Qty	Change Order Qty w/lot multiplier	BPA Pricing	Change Order Amont	Lead Time	User Item Type	Fixed Lot Multiplier	Origianl BPA Pricing	% Increase
31.0	-21.0	-4.2	0.0	0	0.90	\$0.00	84	JEA COMMON SUPPLIES	50	0.44	105%
-103.0	123.0	24.6	147.6	150	5.26	\$789.00	84	JEA COMMON SUPPLIES	10	2.55	106%
22.0	-2.0	-0.4	0.0	0	19.22	\$0.00	84	JEA COMMON SUPPLIES	1	9.32	106%
-253.0	278.0	55.6	333.6	334	26.79	\$8,947.86	84	JEA UNDERGROUND DISTRIBUTION	1	13	106%
-278.0	308.0	61.6	369.6	370	45.16	\$16,709.20	84	JEA UNDERGROUND DISTRIBUTION	1	21.9	106%
1149.0	-1109.0	-221.8	0.0	0	7.87	\$0.00	84	JEA COMMON SUPPLIES	1	3.82	106%
-529.0	649.0	129.8	778.8	779	29.36	\$22,871.44	84	JEA UNDERGROUND DISTRIBUTION	1	14.24	106%
-147.0	187.0	37.4	224.4	225	29.36	\$6,606.00	84	JEA COMMON SUPPLIES	1	6.88	327%
-464.0	504.0	100.8	604.8	605	31.12	\$18,827.60	84	JEA UNDERGROUND DISTRIBUTION	1	15.1	106%
-213.0	313.0	62.6	375.6	400	51.02	\$20,408.00	84	JEA UNDERGROUND DISTRIBUTION	50	24.74	106%
-1.0	11.0	2.2	13.2	14	13.53	\$189.42	84	JEA UNDERGROUND DISTRIBUTION	1	6.56	106%
-8.0	18.0	3.6	21.6	22	16.75	\$368.50	84	JEA UNDERGROUND DISTRIBUTION	1	8.13	106%
-4.0	14.0	2.8	16.8	17	23.84	\$405.28	84	JEA UNDERGROUND DISTRIBUTION	1	11.56	106%
0.0	10.0	2.0	12.0	12	40.59	\$487.08	84	JEA UNDERGROUND DISTRIBUTION	1	19.69	106%
-181.0	221.0	44.2	265.2	275	17.25	\$4,743.75	84	JEA UNDERGROUND DISTRIBUTION	25	8.37	106%
-185.0	245.0	49.0	294.0	294	16.77	\$4,930.38	84	JEA UNDERGROUND DISTRIBUTION	1	8.13	106%
-458.0	548.0	109.6	657.6	658	42.81	\$28,168.98	84	JEA UNDERGROUND DISTRIBUTION	1	20.76	106%
-75.0	105.0	21.0	126.0	126	30.68	\$3,865.68	84	JEA UNDERGROUND DISTRIBUTION	1	14.88	106%

2314.0	-2234.0	-446.8	0.0	0	38.16	\$0.00	84	JEA UNDERGROUND DISTRIBUTION	1
-306.0	456.0	91.2	547.2	548	48.35	\$26,495.80	84	JEA UNDERGROUND DISTRIBUTION	1
-1154.0	1404.0	280.8	1684.8	1685	48.35	\$81,469.75	84	JEA UNDERGROUND DISTRIBUTION	1
-12.0	14.0	2.8	16.8	17	368.66	\$6,267.22	84	JEA UNDERGROUND DISTRIBUTION	1
-66.0	96.0	19.2	115.2	116	126.77	\$14,705.32	84	JEA UNDERGROUND DISTRIBUTION	1
-66.0	96.0	19.2	115.2	116	93.85	\$10,886.60	84	JEA UNDERGROUND DISTRIBUTION	1
-14.0	44.0	8.8	52.8	53	87.66	\$4,645.98	84	JEA UNDERGROUND DISTRIBUTION	1
0.0	0.0	0.0	0.0	0	773.20	\$0.00	84	JEA UNDERGROUND DISTRIBUTION	1
-200.0	277.0	55.4	332.4	333	11.84	\$3,942.72	84	JEA UNDERGROUND DISTRIBUTION	1
2.0	0.0	0.0	0.0	0	186.86	\$0.00	84	JEA UNDERGROUND DISTRIBUTION	1
2.0	0.0	0.0	0.0	0	289.95	\$0.00	84	JEA UNDERGROUND DISTRIBUTION	1
2.0	0.0	0.0	0.0	0	193.30	\$0.00	84	JEA UNDERGROUND DISTRIBUTION	1
83.0	217.0	43.4	260.4	264	62.37	\$16,465.68	84	JEA UNDERGROUND DISTRIBUTION	12
-198416.0	233416.0	46683.2	280099.2	280440	8.51	\$2,386,544.40	84	JEA UNDERGROUND DISTRIBUTION	1140
-12860.0	15860.0	3172.0	19032.0	19240	21.30	\$409,812.00	84	JEA UNDERGROUND DISTRIBUTION	520
-24.0	54.0	10.8	64.8	70	1.50	\$105.00	84	JEA UNDERGROUND DISTRIBUTION	10
6.0	4.0	0.8	4.8	10	0.36	\$3.60	84	JEA UNDERGROUND DISTRIBUTION	10

18.51	106%
23.45	106%
33.12	46%
178.8	106%
61.48	106%
45.52	106%
42.51	106%
375	106%
5.74	106%
90.63	106%
140.63	106%
93.75	106%
30.25	106%
5.59	52%
10.33	106%
1	50%
0.18	100%

-24.0	44.0	8.8	52.8	60	0.09	\$5.40	84	JEA UNDERGROUND DISTRIBUTION	10
40.0	-10.0	-2.0	0.0	0	0.15	\$0.00	84	JEA UNDERGROUND DISTRIBUTION	10
-2544.0	4344.0	868.8	5212.8	7200	2.14	\$15,408.00	84	JEA UNDERGROUND DISTRIBUTION	3600
-1352.0	1752.0	350.4	2102.4	2200	1.91	\$4,202.00	84	JEA UNDERGROUND DISTRIBUTION	100
-25316.0	31316.0	6263.2	37579.2	39200	4.15	\$162,680.00	84	JEA UNDERGROUND DISTRIBUTION	2800
9768.0	-6768.0	-1353.6	0.0	0	8.36	\$0.00	84	JEA UNDERGROUND DISTRIBUTION	1760
128.0	-48.0	-9.6	0.0	0	1.78	\$0.00	84	JEA UNDERGROUND DISTRIBUTION	100
-105.0	165.0	33.0	198.0	198	5.00	\$990.00	84	JEA UNDERGROUND DISTRIBUTION	1
-145.0	245.0	49.0	294.0	294	1.80	\$529.20	84	JEA UNDERGROUND DISTRIBUTION	1
87.0	-61.0	-12.2	0.0	0	9.51	\$0.00	84	JEA UNDERGROUND DISTRIBUTION	1
-10.0	63.0	12.6	75.6	76	0.45	\$34.20	84	JEA UNDERGROUND DISTRIBUTION	1
-103.0	128.0	25.6	153.6	154	6.74	\$1,037.96	84	JEA UNDERGROUND DISTRIBUTION	1
0.0	48.0	0.0	48.0	48	62.37	\$2,993.76	35	JEA UNDERGROUND DISTRIBUTION	1

0.04	125%
0.08	88%
1.04	106%
0.93	105%
2.01	106%
4.05	106%
0.86	107%
2.42	107%
0.88	105%
4.61	106%
0.22	105%
3.27	106%
30.25	106%

Funds Needed \$3,287,542.76
Amount Awarded 2,864,962.81
Amount Released 2,864,864.81
Amount Remaining \$98.00
Change Order Amount \$3,287,444.76
New Not-to-Exceed Amount \$ 6,152,407.57

Warehouse	Item	UOM	TOTAL Usage 48 months	Past 18 Months	Overall Monthly Ave	Past 18 Mons Ave	MAX Monthly Ave	Estimated 19 months usage	Estimated 19 Month Round up	2019 / 02	2019 / 03	2019 / 04	2019 / 05	2019 / 06	2019 / 07	2019 / 08	2019 / 09	2019 / 10	2019 / 11	2019 / 12	2020 / 01	2020 / 02	2020 / 03	2020 / 04	2020 / 05	2020 / 06	2020 / 07	2020 / 08	2020 / 09	2020 / 10	
CSC Stores	CODAD009	EA	2	2	0.04167	0.111	0.111	2.111	3																						
CSC Stores	CODAF010	EA	271	12	5.64583	0.667	5.646	107.3	108	19	1	3	14	6	1	101	2		1						1	1	1		87	4	
CSC Stores	CODBE001	EA	18	2	0.375	0.111	0.375	7.125	8																2						
CSC Stores	CODBE003	EA	229	92	4.77083	5.111	5.111	97.11	98		3		4	3	33	3	2	4			3				6	20	2	3	1	2	
CSC Stores	CODBE004	EA	144	20	3	1.111	3	57	57				20		10		2	4		10								3		16	
CSC Stores	CODCO004	EA	914	181	19.0417	10.06	19.04	361.8	362	2	21	40	19	27	15	15	6	2		2	438	32	34	36	1	10	6	4		9	
CSC Stores	CODCO006	EA	496	219	10.3333	12.17	12.17	231.2	232	20			28		1	4		13			34	2	9	6					2		
CSC Stores	CODCO032	EA	419	180	8.72917	10	10	190	190		24	30		20					10		2	30	40	30				2	20		
CSC Stores	CODCO033	EA	515	255	10.7292	14.17	14.17	269.2	270		2			24	11		29	3	22			2	48		30		25	3		8	
CSC Stores	CODCO034	EA	356	202	7.41667	11.22	11.22	213.2	214	12											8							12	2	20	
CSC Stores	CODCO040	EA	16	10	0.33333	0.556	0.556	10.56	11																			2		4	
CSC Stores	CODCO041	EA	13	10	0.27083	0.556	0.556	10.56	11																			3			
CSC Stores	CODCO042	EA	28	6	0.58333	0.333	0.583	11.08	12													4				4					
CSC Stores	CODCO043	EA	9	6	0.1875	0.333	0.333	6.333	7												2					1					
CSC Stores	CODEF002	EA	567	27	11.8125	1.5	11.81	224.4	225	34	12	6	18	42	8	202	6		2		1				2	4	2		174	4	
CSC Stores	CODEP001	EA	594	161	12.375	8.944	12.38	235.1	236	3	24	50	30	22	35		4	2	1	2	76		31	16	35	10	8		20	4	
CSC Stores	CODEP002	EA	1494	474	31.125	26.33	31.13	591.4	592	6	50	34	42	31	94	37	15	4	21	30	156	14	49	55	103	46	16	28	9	48	
CSC Stores	CODEP003	EA	445	296	9.27083	16.44	16.44	312.4	313	15	2	26		5	2	11		6		1	3	3	22	3	2	3	1	1		9	
CSC Stores	CODEP004	EA	1245	487	25.9375	27.06	27.06	514.1	515	9	21	14	6	9	24	25	10	9	6	10	407	14	4	16	11	13	18	11	4	38	
CSC Stores	CODEP005	EA	858	296	17.875	16.44	17.88	339.6	340	14	21	19	26	43	18	6	22	26	9	5	22	13	59	38	29	5	26		5	18	
CSC Stores	CODEP006	EA	2953	1046	61.5208	58.11	61.52	1169	1169	70	90	73	75	91	100	18	49	59	252	42	68	42	73	80	99	27	23	41	36	73	
CSC Stores	CODEP008	EA	27	16	0.5625	0.889	0.889	16.89	17																					3	
CSC Stores	CODEP009	EA	306	83	6.375	4.611	6.375	121.1	122	3				24	14	1	1	2			27	4	6	6	6			2	2	7	
CSC Stores	CODEP010	EA	137	68	2.85417	3.778	3.778	71.78	72	2	1		12		8						20		1								
CSC Stores	CODEP011	EA	114	38	2.375	2.111	2.375	45.13	46				16						6											2	
CSC Stores	CODEP024	EA	880	259	18.3333	14.39	18.33	348.3	349	137	7	4	12	7	3	2		1	27	17	78	4	4	57	98		18	6	40	22	
CSC Stores	CODKT001	EA	2201	638	45.8542	35.44	45.85	871.2	872	73	46	39	142	38	31	46	41	39	33	30	141	121	78	21	21	140	23	28	18	41	
CSC Stores	CODPC003	FT	5E+05	196332	10777.7	10907	10907	2E+05	2E+05	13,650	14,055	7,195	35,110	20,321	16,360	2,960	17,020	9,630	5,080	4,930	10,070	4,800	13,160	18,120	2,720	1,260	2,580	14,025	2,151	16,685	
CSC Stores	CODPC005	FT	57769	29587	1203.52	1644	1644	31231	31231	440			15,180	790	590	30	20	40	60		1,000	100	180	1,040				100	160	1,760	
CSC Stores	CODPC012	FT	212	60	4.41667	3.333	4.417	83.92	84		1											10				19	2		38	2	
CSC Stores	CODPC013	FT	110	20	2.29167	1.111	2.292	43.54	44													10				10	10				
CSC Stores	CODPC014	FT	100	60	2.08333	3.333	3.333	63.33	64														20								20
CSC Stores	CODPC015	FT	231	151	4.8125	8.389	8.389	159.4	160			50																			
CSC Stores	CODPC016	FT	27276	3952	568.25	219.6	568.3	10797	10797	2,978	210	410	740	652	170	7,390	140	300	190	130	712	48	124	210	70	850	20	30	6,090	290	
CSC Stores	CODPC017	FT	7685	1456	160.104	80.89	160.1	3042	3042	540	100	280	100	150	150	1,200	140	100	445	200	200				100	100			1,200	100	
CSC Stores	CODPC019	FT	71461	16019	1488.77	889.9	1489	28287	28287	680	680	6,460	1,180	5,620	2,900	1,690	2,040	120	221	2,860	6,079	60	1,722	5,240	1,240	1,080	680		60	1,225	
CSC Stores	CODPC020	FT	11057	3274	230.354	181.9	230.4	4377	4377	10	450	570	55	60	230	315	105	2	20	20	2,475	310	175	1,920		40	80	1		200	
CSC Stores	CODPL001	EA	379	39	7.89583	2.167	7.896	150	151			10		2	42	4	6	2	4	8	137	8	2	2	8	8	4			52	
CSC Stores	CODPL004	EA	347	109	7.22917	6.056	7.229	137.4	138	2	2	6	2	35	2	1	4	8	2	15	10	4	10	6	10			4		42	
CSC Stores	CODPL005	EA	255	169	5.3125	9.389	9.389	178.4	179				1	2	2				1			45		2				2		9	3
CSC Stores	CODRC043	EA	5	2	0.10417	0.111	0.111	2.111	3																						
CSC Stores	CODSC002	EA	101	0	2.10417	0	2.104	39.98	40				26	50	25																
CSC Stores	CODWH002	EA	329	21	6.85417	1.167	6.854	130.2	131	18	13	3	10	11	3	103	3	15	1	1	5				16	1	1		86	2	

2020 / 11	2020 / 12	2021 / 01	2021 / 02	2021 / 03	2021 / 04	2021 / 05	2021 / 06	2021 / 07	2021 / 08	2021 / 09	2021 / 10	2021 / 11	2021 / 12	2022 / 01	2022 / 02	2022 / 03	2022 / 04	2022 / 05	2022 / 06	2022 / 07	2022 / 08	2022 / 09	2022 / 10	2022 / 11	2022 / 12	2023 / 01	
																				2							
1		1	4	7		3					1			4			1	1	1	1	2					1	
				6							2																
	10	2		6	8		2	20		64				1		7			1	4			4	4		7	
				4			1	54		14																6	
1	7			2			2	2	9	11	1	2	27	5	20	57	3	8	2	10	18	5		2		1	
		21	58	42	9		28		40	14	16	4	8	30	36	4	2			36				1		28	
	3					3	25		29	2				6	12		10	10	12		1		70		4	24	
	8	6	4	10	10	11		4	36			15				45	70	24	8	12	4	12	8			21	
		22		22	48		8		4	10	40		4	31		54	4	11	24				4			16	
															8					2							
												4													6		
2	8							4								4				2							
									2							4											
2		2	2	11	2		2	2	4		2			6			3	4	2	2	2					2	
15		9	2	9		8	5	12	31	8	2	5	8			25		2	3	20	4	12	3	8	16	14	
34	32	6	9	24		8	6	13	73	20	23	10	14	7	61	43	14	5	11	103	29	9	7	7	10	28	
3	1	5		3	1	7	5	9	17	2	5		27	6	4	13		4		15	13	8	174			8	
22	8	8	6	3	2	10	7	13	3	7	5	6	209			182	9	5			45	7		1	2	6	
20	1	7		18	33	13	25	21	15	46	19	1	4	16	14	26	10	19	7	17	18	11	10	11	12	40	
46	80	23	21	80	95	16	41	24	87	20	30	33	49	49	38	90	21	115	50	49	128	64	92	32	33	66	
					6	2					9					6		1									
26	5	4	10	36	8	2	27		14	5	12	4		11		4	2	4		5			9			13	
		4		12	2	2	3			19	2			16	5				6	12	6			2			
		22		12	1	5	12			13										17							
22	24	1	6	14	6	2	2		7	6	8	11	34	2	1	24	6	7	6	63	20	12	46	3		3	
36	16	21	19	71	85	30	34	61	19	53	24	25	7	34	46	48	84	31	18	127	34	20	11	20	20	17	
10,132	5,500	4,860	3,160	17,040	33,250	3,100	7,880	4,195	10,550	4,400	6,164	7,290	9,140	5,740	4,560	26,685	6,000	3,680	9,780	481	57,103	2,040	26,947	3,781	2,819	9,172	
3,772	80	600	60	790	1,120	10	260		17,500	1,660	1,080	3,140		920		1,040	60	520	20	460			687	520		1,980	
10	20		40					10								30				10		20					
			60						10							10											
												10								10				40			
			30									20		40		10					10		60	10		1	
230	100	62	67	568	160	174	110	99	146	10	270	200	276	100	292	480	210	190	320	250	388	130	460	150		80	
100			100	600	100	20	4	200	100		20		80	1		200	115	405	105	200	220					10	
5,360	2,310	200	100	2,580		2,260	720	75	1,406	865	843	856	2,320	135	940	330	110	470	200		214	460	400	2,000	1,026	3,444	
40	20		60	25		360	40	200	40	201	120	20	45	135	200	470	10	360	70	20	403	520	370	210		80	
10	2	3	2	12		8	4				1		1			27		1	2				5	2			
22			8	4	20	4	7	8	18	6	9	4	14	8				3	4	17	4		8	4		10	
4		1	4	6	2	2			3	3	3	3	3	3	1	2	112	2	5	4	11	7	9			1	
							3			2																	
1		1	1	7	2	3		1			1	5		2	1	1	1	1	5	1	1	2				1	

CSC Stores	CODAD004	ADAPTER, MALE, 1", PVC	EA	163	0.32
CSC Stores	CODAD009	ADAPTER, CONDUIT, PVC, SCH- 40 W/LOCKNU T, MALE, 2"	EA	1	0.44
CSC Stores	CODAD011	ADAPTER, CONDUIT, PVC, SCH- 40, WITH LOCKNUT, FEMALE, 3"	EA	1	1.95
CSC Stores	CODAD012	ADAPTER, CONDUIT, PVC, SCH- 40, WITH LOCKNUT, FEMALE, 4"	EA	2	2.62
CSC Stores	CODAF010	ACCESS FITTING, 1", TYPE LB SCHEDULE 40, PVC	EA	117	2.55
CSC Stores	CODBE001	BELL-END, 2", PVC, TYPE EB,	EA	5	9.32
CSC Stores	CODBE002	BELL-END, 3", PVC, TYPE EB	EA	15	13.59
CSC Stores	CODBE003	BELL-END, 4", PVC, TYPE EB,	EA	50	13
CSC Stores	CODBE004	BELL END, 6 IN. TYPE EB	EA	33	21.9
CSC Stores	CODCO003	COUPLING, CONDUIT, PVC, 2", SCH- 40 LONG LINE	EA	550	5.07
CSC Stores	CODCO004	COUPLING, CONDUIT, PVC, 3", SCH- 40	EA	367	3.82
CSC Stores	CODCO005	COUPLING, CONDUIT, PVC, 4", SCH- 40	EA	800	16.11

CSC Stores	CODCO006	COUPLING, CONDUIT, PVC, 6", TYPE SCH-40	EA	95	14.24
CSC Stores	CODCO014	COUPLING, 1-1/2", PVC	EA	20	3.86
CSC Stores	CODCO025	COUPLING, 1" PVC SCHEDULE- 40	EA	273	0.2
CSC Stores	CODCO031	COUPLING, CONDUIT, SCH-40 PVC, REPAIR, 2" SLIP TYPE	EA	195	6.21
CSC Stores	CODCO032	COUPLING, CONDUIT, SCH-40 PVC, REPAIR, 3" SLIP TYPE	EA	107	6.88
CSC Stores	CODCO033	COUPLING, CONDUIT, SCH-40 PVC, REPAIR, 4" SLIP TYPE	EA	113	15.1
CSC Stores	CODCO034	COUPLING, CONDUIT, SCH-40 PVC, REPAIR, 6" SLIP TYPE	EA	33	24.74
CSC Stores	CODCO040	COUPLING, 2 INCH SPLIT- DUCT, 6" MINIMUM LENGHT.	EA	3	6.56
CSC Stores	CODCO041	COUPLING, 3 INCH SPLIT- DUCT, 7" MINIMUM LENGHT.	EA	2	8.13
CSC Stores	CODCO042	COUPLING, 4 INCH SPLIT- DUCT, 6" MINIMUM LENGHT.	EA	10	11.56

CSC Stores	CODCO043	COUPLING, 6 INCH SPLIT- DUCT, 10" MINIMUM LENGHT.	EA	2	19.69
CSC Stores	CODEF002	CONNECTO R, FLEXIBLE PVC, 90DEGREE, 1" PACKAGED 25-UNITS PER CARTON	EA	250	8.37
CSC Stores	CODEP001	ELBOW, PVC, CONDUIT, 2", 45DEGREE 36" SWEEP- RADIUS, SCH-40, WITH INTEGRAL BELL END	EA	200	8.13
CSC Stores	CODEP002	ELBOW, PVC, CONDUIT, 2", 90DEGREE 48" SWEEP- RADIUS, SCH-40, WITH INTEGRAL BELL END	EA	500	20.76
CSC Stores	CODEP003	ELBOW, PVC, CONDUIT, 3", 45DEGREE 36" SWEEP- RADIUS, SCH-40, WITH INTEGRAL BELL END	EA	57	14.88

CSC Stores	CODEP004	ELBOW, PVC, CONDUIT, 3", 90DEGREE 36" SWEEP- RADIUS, SCH-40,	EA	367	18.51
------------	----------	---	----	-----	-------

		WITH INTEGRAL BELL END			
CSC Stores	CODEP005	ELBOW, PVC, CONDUIT, 4", 45DEGREE 36" SWEEP-RADIUS, SCH-40, WITH INTEGRAL BELLED END.	EA	233	23.45
CSC Stores	CODEP006	ELBOW, PVC, CONDUIT, 4", 90DEGREE 36" SWEEP-RADIUS, SCH-40, WITH INTEGRAL BELL END	EA	833	33.12
CSC Stores	CODEP008	ELBOW, PVC, CONDUIT, 6", 45DEGREE 150" SWEEP-RADIUS, TYPE DB-60, WITH INTEGRAL BELLED END	EA	2	178.8
CSC Stores	CODEP009	ELBOW, PVC, CONDUIT, 6", 90DEGREE 48" SWEEP-RADIUS, SCH-40, WITH INTEGRAL BELLED END	EA	83	61.48
CSC Stores	CODEP010	ELBOW, PVC, CONDUIT, 6", 45DEGREE, 48" SWEEP-RADIUS, SCH-40, WITH INTEGRAL BELLED END	EA	23	45.52

CSC Stores	CODEP011	ELBOW, PVC, CONDUIT, 6", 22.5DEGRE E 48" SWEEP- RADIUS, SCH-40. WITH INTEGRAL BELLED END	EA	23	42.51
CSC Stores	CODEP012	ELBOW, STANDARD , 6", 90- DEGREE 30" SWEEP- RADIUS. WITH-OUT BELL END	EA	13	42.27
CSC Stores	CODEP013	ELBOW, PVC, CONDUIT, 6", 90DEGREE 150" SWEEP- RADIUS, SCH- 40, WITH INTEGRAL BELLED END	EA	1	375
CSC Stores	CODEP021	ELBOW, PVC, 2", 36" RADIUS, 90 DEGREE	EA	3	24.45
CSC Stores	CODEP024	ELBOW, 1" PVC 90- DEGREE, 18" RADIUS SCH-40	EA	230	5.74
CSC Stores	CODEP025	ELBOW, 1" PVC 45- DEGREE, 18" RADIUS SCH-40	EA	28	6.19
CSC Stores	CODEP026	ELBOW, PVC 3", SCH.-40, 13"- RADIUS ONE BELLED END OR COUPLING, 90DEGREE	EA	3	12.21

CSC Stores	CODEP030	ELBOW, REPAIR, PVC, CONDUIT, 4", 45- DEGREE, 36" SWEEP- RADIUS, SCH40	EA	1	90.63
CSC Stores	CODEP031	ELBOW, REPAIR, PVC, CONDUIT, 6", 90- DEGREE, 36" SWEEP- RADIUS, SCH40	EA	1	140.63
CSC Stores	CODEP032	ELBOW, REPAIR, PVC, CONDUIT, 4" 90-DEGREE 36" SWEEP- RADIUS	EA	1	93.75
CSC Stores	CODKT001	KIT, RISER PLUG, FOR CONDUIT RISERS AND CABLE GUARDS UP TO 6" DIAMETER.	EA	636	30.25
CSC Stores	CODPC003	CONDUIT, PVC, 4", SCH-40, W/COUPLI NG ATTACHED OR ONE BELLED END, 20' SECTIONS END WITHOUT COUPLING MUST BE CHAMFERE D 40- DEGREES SHIPPED ON OPEN FLAT BED TRUCK	FT	123,500	5.59
		CONDUIT, PVC, 6", SCH-40,			

CSC Stores	CODPC005	W/COUPLI NG ATTACHED OR ONE BELLED END, 20' SECTIONS END WITHOUT COUPLING MUST BE CHAMFERE D 40- DEGREES SHIPPED ON OPEN FLAT BED TRUCK	FT	20,000	10.33
------------	----------	--	----	--------	-------

CSC Stores	CODPC010	CONDUIT, PVC 1 1/2 " TYPE SCHEDULE 40 W/COUPLI NG ATTACHED, OR BELLED END 10' LENGTHS	FT	417	2.02
CSC Stores	CODPC011	CONDUIT, PVC 2" TYPE SCHEDULE 40 W/COUPLI NG ATTACHED, OR BELLED END 10' LENGTHS	FT	147	2.52
CSC Stores	CODPC012	CONDUIT, PVC, 4", SCH-40, SPLIT 10FOOT SECTIONS SHIPPED ON OPEN FLAT BED TRUCK SUITABLE FOR FORKLIFT UNLOADIN G	FT	73	0.1

CSC Stores	CODPC013	CONDUIT, PVC, 6", SCH-40, SPLITDUCT 10-FOOT SECTIONS SHIPPED ON OPEN FLAT BED TRUCK SUITABLE FOR FORKLIFT UNLOADIN G	FT	47	0.18
CSC Stores	CODPC014	CONDUIT, PVC, 2", SCH-40, SPLITDUCT 10-FOOT SECTIONS SHIPPED ON OPEN FLAT BED TRUCK SUITABLE FOR FORKLIFT UNLOADIN G	FT	20	0.04
CSC Stores	CODPC015	CONDUIT, PVC, 3", SCH-40, SPLITDUCT 10-FOOT SECTIONS SHIPPED ON OPEN FLAT BED TRUCK SUITABLE FOR FORKLIFT UNLOADIN G	FT	40	0.08
CSC Stores	CODPC016	CONDUIT, PVC, 1" SCHEDULE- 40, 10' LONG PACKAGED 10-UNITS PER BUNDLE	FT	10,800	1.04
CSC Stores	CODPC017	CONDUIT, FLEXABLE PVC, 1"NONMET ALIC PACKAGED 100-FEET PER	FT	2567	0.93

		POLYPACK			
CSC Stores	CODPC019	CONDUIT, PVC, 2", SCH-40, W/COUPLI NG ATTACHED OR ONE BELLED END, 20' SECTIONS END WITHOUT COUPLING MUST BE CHAMFERE D 40- DEGREES SHIPPED ON OPEN FLAT BED TRUCK	FT	25,200	2.01
CSC Stores	CODPC020	CONDUIT, PVC, 3", SCH-40, W/COUPLI NG ATTACHED OR ONE BELLED END, 20' SECTIONS END WITHOUT COUPLING MUST BE CHAMFERE D 40- DEGREES SHIPPED ON OPEN FLAT BED TRUCK	FT	4,107	4.05
CSC Stores	CODPC031	CONDUIT, PVC, 6", TYPE DB- 60, W/COUPLI NG ATTACHED OR ONE BELLED END, 20' SECTIONS SHIPPED ON OPEN FLAT BED TRUCK SUITABLE FOR FORKLIFT UNLOADIN	FT	10	10.03

CSC Stores	CODPL001	PLUG, CONDUIT, PVC, 2" ID, TYPE EB	EA	167	0.86
CSC Stores	CODPL002	PLUG, CONDUIT, PVC, 3" ID, TYPE EB	EA	92	2.21
CSC Stores	CODPL003	PLUG, CONDUIT, PVC, 4" ID, TYPE EB	EA	533	2.26
CSC Stores	CODPL004	PLUG, CONDUIT, PVC, 6" ID, TYPE EB	EA	100	2.42
CSC Stores	CODPL005	PLUG, PVC CONDUIT, 1" I.D., CAP- TYPE	EA	38	0.88
CSC Stores	CODRC043	COUPLING, CONDUIT REDUCER PVC SCH-40; 4" SPIGOT TO 3" BELL END	EA	1	4.61
CSC Stores	CODSC002	STRAP, CONDUIT, PVC, 1", 2- HOLE PACKAGED 400-UNITS PER CARTON	EA	50	0.22
CSC Stores	CODWH002	WEATHERH EAD, PVC, 1" PACKAGED 15-UNITS PER CARTON	EA	140	3.27
		TOTAL (BY ITEM) WINNING LOW BID ITEMS			#####